



# Munters

## OPERATING AND MAINTENANCE MANUAL

MODEL: HC-300 / DEW-300

### Section 1

- a) Operating and Maintenance Text

### Section 2

- a) General Arrangement Drawing ..... 74119
- b) Wiring Diagram 208-240 /1/ 50/60 ..... 50339
- c) Wiring Diagram 208-240 /3/ 50/60 ..... 50340
- d) Wiring Diagram 380-415 /3/ 50/60 ..... 50341
- e) Wiring Diagram 460 /3/ 50/60 ..... 50342
- f) Wiring Diagram 208-240 /3/ 50/60 ..... 50344

### Section 3

- a) Replacing Fusible Links
- b) Humidistat Field Connections ..... 26992
- c) Blastgate Installation Instructions ..... 27110
- d) Recommended Spare Parts List ..... 21239



**OPERATING AND  
MAINTENANCE  
MANUAL  
MODEL HC-300  
DEHUMIDIFIER**

---

# TABLE OF CONTENTS

HC-300

---

SECTION 1 — INTRODUCTION .....	PAGE 1-1
1.1 Dehumidifier Operating Principle .....	1-1
1.2 About the HC-300 .....	1-2
1.3 Controls and Indicators .....	1-3
1.4 Protective Circuits .....	1-4
SECTION 2 — SAFETY NOTES .....	2-1
SECTION 3 — INSTALLATION AND START-UP .....	3-1
3.1 Inspection .....	3-1
3.2 Positioning the Unit .....	3-1
3.3 Connecting the Ductwork .....	3-3
3.4 Electrical Connections .....	3-6
3.5 Connecting the Remote Humidistat .....	3-6
3.6 Adjusting the Damper .....	3-7
SECTION 4 — PREVENTIVE MAINTENANCE .....	4-1
4.1 Clean the Air Filters .....	4-1
4.2 Check the Honeycombe Wheel .....	4-1
4.3 Check the Upper and Lower Air Seals .....	4-1
4.4 Check the Reactivation Outlet Temperature .....	4-1
SECTION 5 — TROUBLESHOOTING .....	5-1
5.1 Possible Trouble Conditions .....	5-1
5.2 Auto/Off/Manual Switch is Set to Auto, Running Light Does Not Come On .....	5-1
5.3 Fault Light is On, and Machine Should Be Running .....	5-1
5.4 Reactivation Outlet Temperature is Too Low .....	5-2
5.5 Poor Dehumidifying Performance .....	5-3
5.6 HoneyCombe Wheel is Stopped, Running Light is On .....	5-3
5.7 Checking the Heating Elements .....	5-4
5.8 Checking the Thermistor .....	5-4
5.9 Checking the Humidistat .....	5-5
5.10 Checking the Drive Motor, Wheel and Seals .....	5-5

---

LIST OF FIGURES

Fig. 1-1	Operating Principle .....	PAGE 1-1
Fig. 1-2	HC-300 in Operation .....	1-2
Fig. 1-3	Controls and Indicators .....	1-3
Fig. 1-4	Front View, Cover Open .....	1-4
Fig. 3-1	Dimensions .....	3-1
Fig. 3-2	HC-300 Installed in Process Space .....	3-2
Fig. 3-3	HC-300 Installed Outside of Process Space .....	3-3
Fig. 3-4	HC-300 Installed with Existing Air-Handling Unit .....	3-4
Fig. 3-5	Do Not Install HC-300 This Way .....	3-5

---

# 1 - INTRODUCTION

---

Your HC-300 dehumidifier is durable, simple to operate, and needs very little maintenance. The HC-300 can give you years of trouble-free service if you follow the recommendations listed in this manual.

We strongly recommended that you read this whole manual. This should not take very long. In return, you will learn how your dehumidifier works, and how to get the best service from your unit.

If you do not understand something in this manual, or you have a question about your dehumidifier, please call Munters at (978) 241-1100 or send a fax to (978) 241-1217. Ask to speak with one of our Technical Support people.

## 1.1 DEHUMIDIFIER OPERATING PRINCIPLE

Figure 1-1 shows how the HC-300 removes moisture from the air. The heart of the system is the HoneyCombe® wheel. The detail in Fig. 1-1 shows the structure of the wheel. As you can see, the wheel has a series of air passages or channels. The passages inside the wheel are coated with a special substance called a "desiccant." When this substance contacts damp air, it soaks up moisture. When the desiccant is heated, it releases the moisture again.

Let's say that you want to dry the air in a storage room, using the HC-300. Damp "process" air is pulled into the unit from the storage room. The desiccant in the HoneyCombe® wheel picks up most of the moisture in the air. Once it has been "dried out," the process air is vented back into the storage room. At this point, the moisture has been taken out of the process air, and "stored" in the HoneyCombe® wheel.

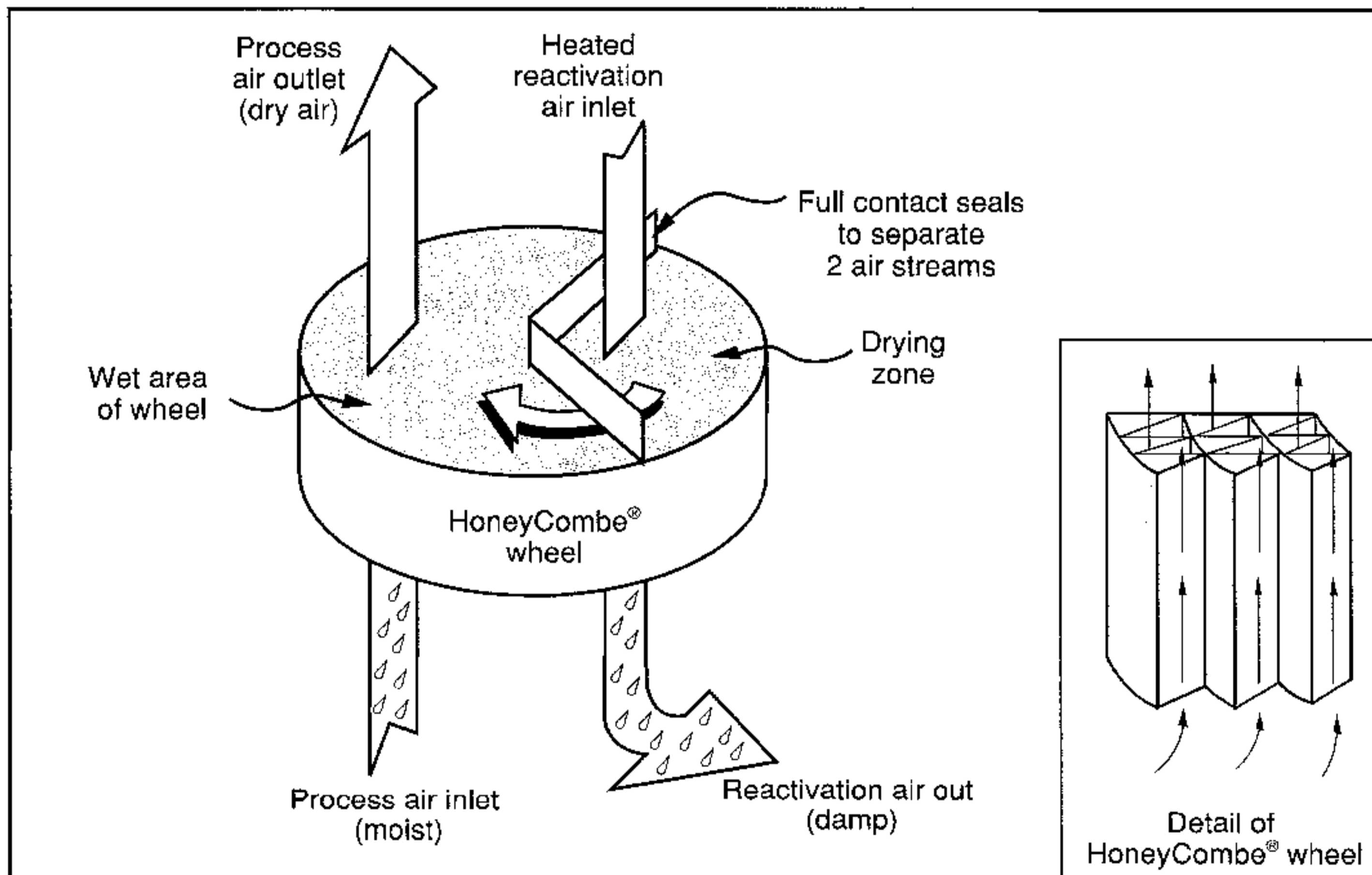

FIGURE 1-1  
OPERATING PRINCIPLE

The next job is to move this moisture out of the wheel. As we said, the desiccant will give up moisture when it is heated. When it is heated, and the moisture released, we say it is "reactivated." In the HC-300, a stream of "reactivation" air is taken from outside the controlled space and heated using an electric heater. This heated air is forced through the channels in the HoneyCombe® wheel. The desiccant releases the moisture into the heated air stream. Finally, the damp reactivation air is vented outside. At this point, the moisture has been moved from the storage room to the wheel, then from the wheel into the outside air. The process is complete.

You may have noticed that, at one moment, we're using the wheel to pick up moisture, and a moment later, we're heating the wheel to drive off the moisture. In the HC-300, both actions are happening at the same time, on different sections of the wheel.

## 1.2 ABOUT THE HC-300

This is a simplified explanation of the operating principle. Figure 1-2 shows how we put this principle to work in the HC-300. You can still see the parts we discussed in the last Figure – the HoneyCombe® wheel, process air stream and reactivation air stream. We have also added a number of other parts:

- Two sets of seals to separate the two streams of air (damp process air and the heated reactivation air)
- Blower, damper and filter for the process air
- Blower and filter for the reactivation air
- Temperature sensors
- Electric heating elements for the reactivation air

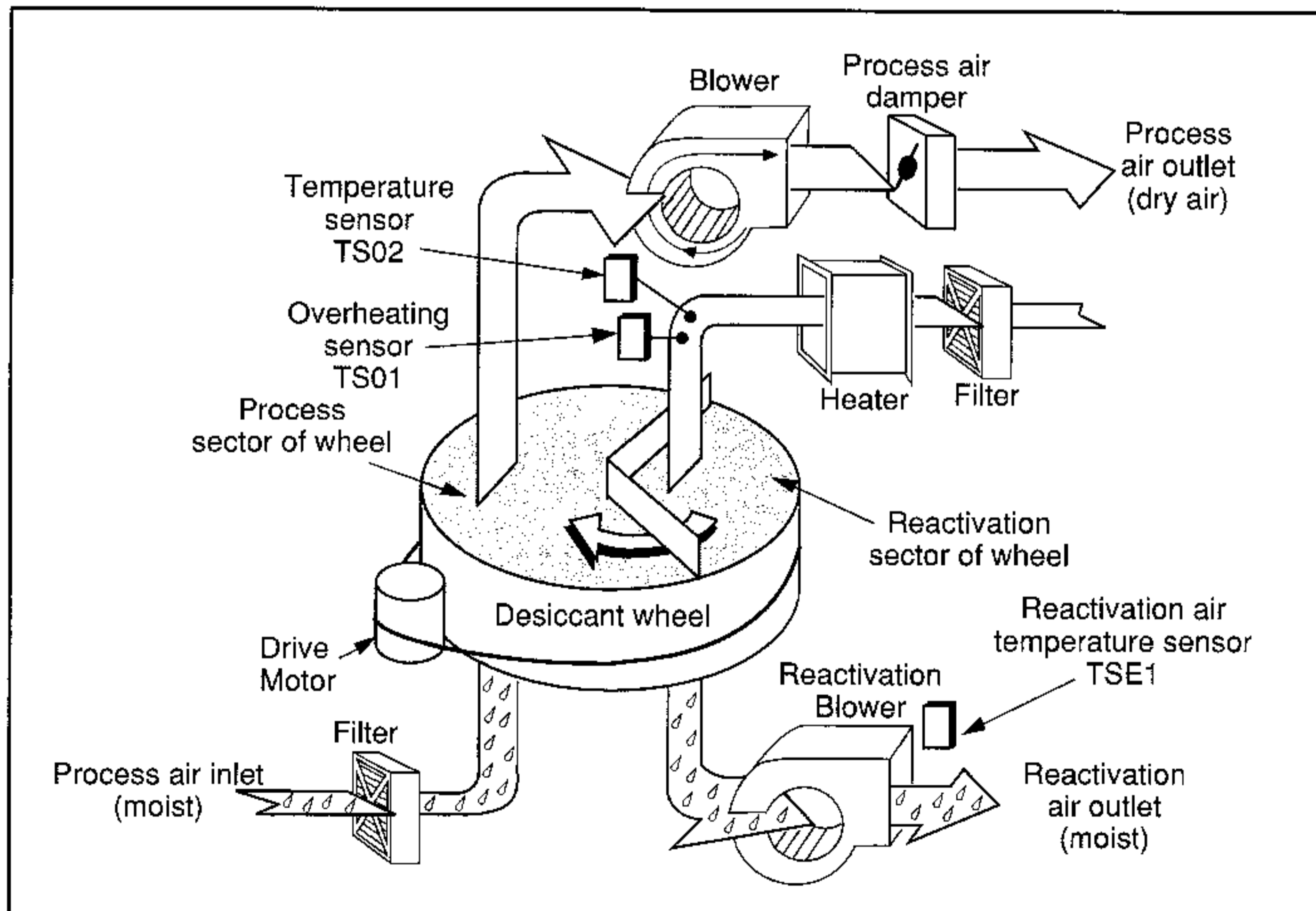

FIGURE 1-2  
HC-300 IN OPERATION

04016

---

Figures 1-3 and 1-4 show some additional parts on the HC-300 unit. The HoneyCombe® wheel is turned by a small drive motor and a toothed belt. A spring-type tensioner automatically adjusts the belt tension.

### 1.3 CONTROLS AND INDICATORS

The unit has four indicators and controls on the control panel:

#### Auto/Off/Manual switch:

- Auto position (amber)** This indicator is on whenever the HC-300 is operating in the automatic mode. The unit is switched on and off by a remote humidistat.
- Off position (amber)** This indicator is on when the AC power to the unit is on, and it is not running (not set to Auto or Manual). (On shut-down, the heating elements will switch off. The reactivation blower will continue to run to cool down the unit. Once cooled down, the unit will become inactive.)
- Manual position (amber)** This indicator is on whenever the HC-300 is operating in the manual mode. The unit runs continuously until it is switched off.
- Running light (green)** This indicator is on whenever the unit is running (the Auto/Off/Manual switch is in the Manual position, or the switch is in the Auto position and the humidistat contacts are closed).
- Fault light (red)** This indicator is normally off. This light turns on when the unit overheats. See the section on "Troubleshooting."
- Time meter** This indicator shows how many hours the unit has operated.

The control system uses a number of sensors and controllers to supervise the activity of the HC-300. A Solid State Power Controller (SSP1) turns the heating elements on and off. This controller responds to a signal from a temperature sensor (TSE1) which is

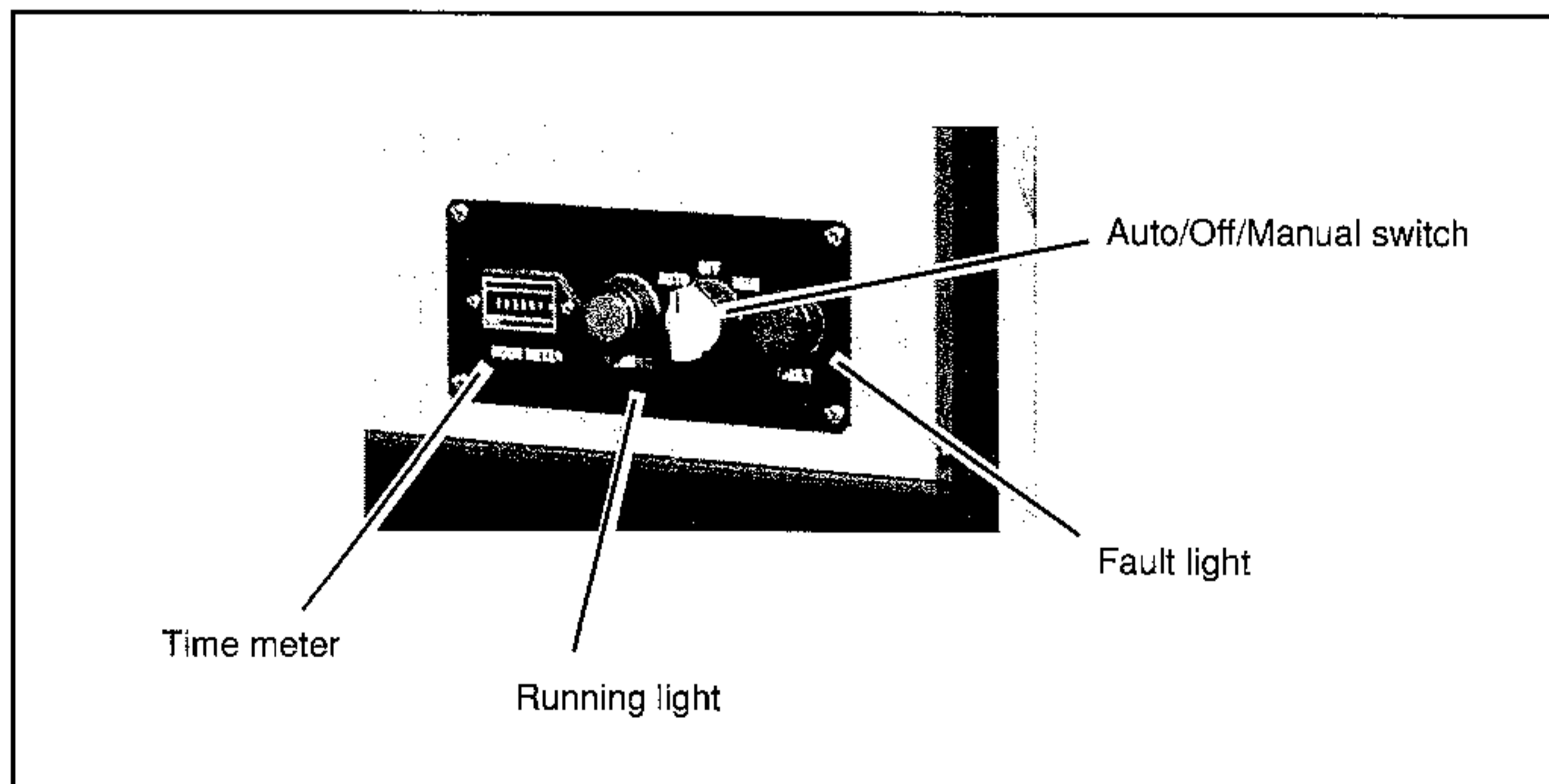

FIGURE 1-3  
CONTROLS AND INDICATORS

---

located in the reactivation air stream after the wheel. This design allows reduced energy consumption at low load levels.

The unit continues to run for a few minutes after the Auto/Off/Manual switch is turned off. This "cool-down" cycle helps to protect the heating elements from overheating. During the cycle, the reactivation blower continues to operate. The "cool-down" period is controlled by a thermostat switch (TS02).

#### 1.4 PROTECTIVE CIRCUITS

The HC-300 has several sensors and circuits which protect the machine and operator from possible problems. A temperature switch (TS01) is located just downstream of the heater. This sensor will tell the control circuits if the elements overheat (temperature above 320°F). If this happens, the Fault indicator will light and the machine will stop. To reset the machine, wait until the unit cools to normal temperature. Turn the Auto/Off/Manual switch off, then on again.

The wiring for each heating element includes a fusible link. This link will open if the element overheats. If this happens, the HC-300 will continue to operate, but will not dehumidify the process air. To correct this, find the cause of the overheat condition and replace the fusible link.

If a blower motor is jammed, it will start to draw a large amount of electrical current. If one of the motors detects this condition, that motor will shut itself down. The rest of the unit will continue to operate, unless an overheat fault is triggered. The affected motor will reset itself automatically.

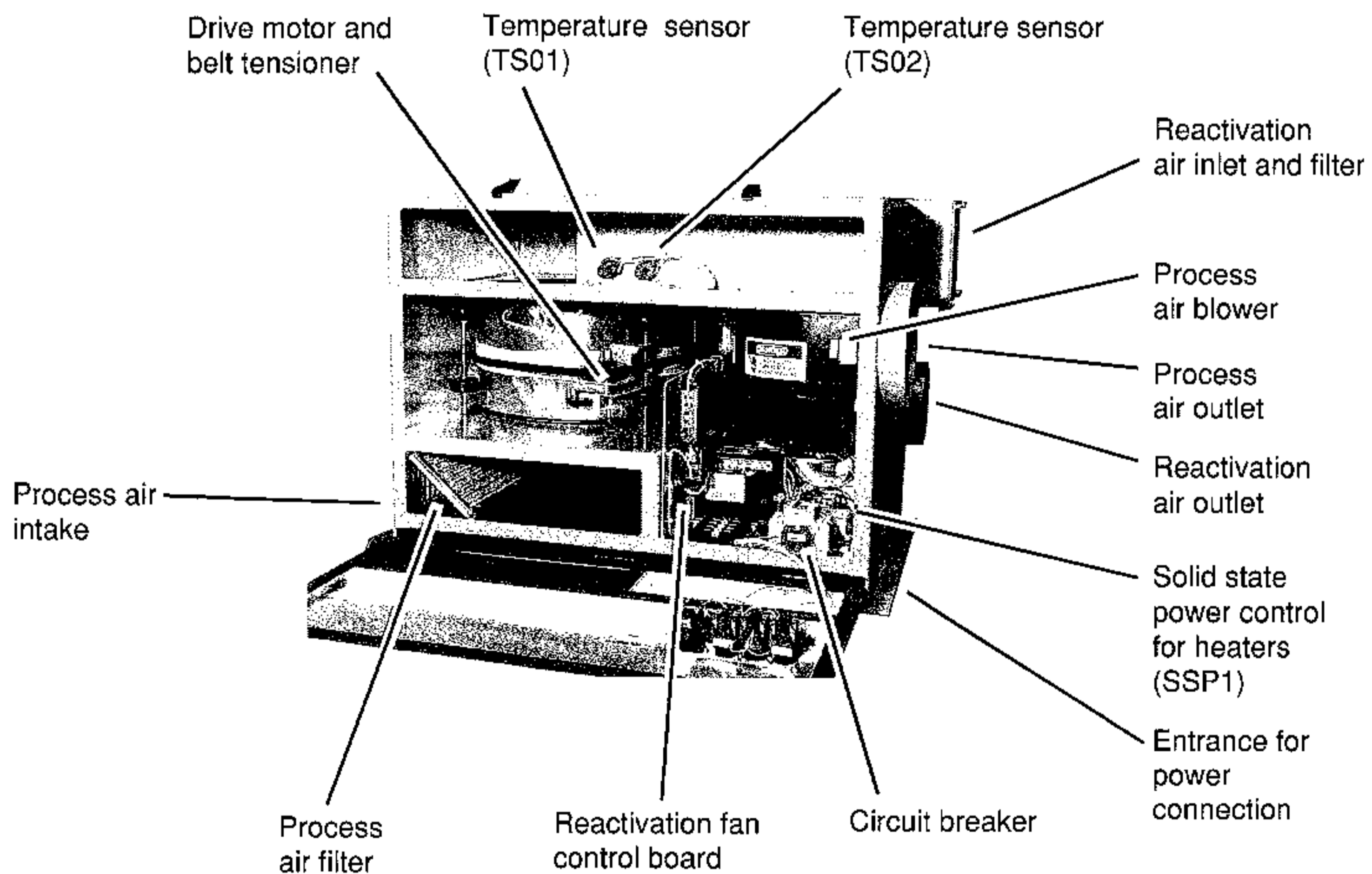

FIGURE 1-4  
FRONT VIEW, COVER OPEN

---

## 2 - SAFETY NOTES

---

Munters is concerned about the safety of anyone who uses or services the HC-300 unit. Some of the parts inside the HC-300 can be dangerous if an untrained person tries to service the unit. Throughout this manual, we have pointed out some of the hazards which may occur in the use of the HC-300. We have also listed the precautions which you should take to avoid these problems.

In this manual, we will use three different kinds of messages to warn you of possible problems:



Immediate hazard which will result in severe personal injury or death.



Hazard or unsafe practice which may result in severe personal injury or death.



Hazard or unsafe practice which could result in minor personal injury or property damage.

Please keep these points in mind as you use or service the unit:



The HC-300 is wired for 208V to 480V AC. The unit can produce enough voltage and current to kill you, or cause severe burns. Do not work with the electrical parts unless you are a trained electrician. Always turn off the power before you work inside the unit. There should be a disconnect switch installed outside the unit. Turn off this switch before you do any work. For extra safety, also turn off the circuit breaker inside the unit.



Some HC-300 units are purchased with an optional humidistat. If wired incorrectly, the contacts inside the humidistat may carry a high voltage. This voltage and current can cause serious injury or death. Don't work on the parts inside the humidistat unless you are a trained electrician.

---

## **CAUTION**

Don't place the HC-300 unit outdoors. The cabinet is not weather-proof. If the unit is mounted outdoors, water may drip into the electrical parts. This may cause an electrical shock hazard.

## **WARNING**

The two blowers inside the HC-300 spin very quickly. Your hand may be hurt if you put it inside a blower while it is turning. Keep your hands away from the blowers while the unit is turned on. Do not run the HC-300 unless both the process and reactivation fans are protected by ductwork or finger guards.

## **WARNING**

There are two conditions which could cause the unit to start without warning:

- When the Auto/Off/Manual switch is set to Auto, the unit may start if the humidistat contacts close.
- The motors on the blowers have internal over-current protection. If one of these blowers is overloaded, the affected motor will turn itself off. This over-current protection will reset automatically, so the blower may start without warning.

You can avoid either kind of problem if you turn off the power before working on the unit.

## **CAUTION**

This type of wheel is washable. It is best to clean the wheel using clean water only. If you must use a detergent, choose a mild type (enzyme or dish-washing detergent). The wheel is sensitive to high pH (base condition). Choose a detergent with a neutral pH. Do not use any solvent to wash the wheel. This will permanently damage the wheel.

PLEASE READ ALL OF THIS MANUAL. PLEASE FOLLOW THE INSTRUCTIONS CAREFULLY AND COMPLETELY. PLEASE PAY PARTICULAR ATTENTION TO THE SAFETY INSTRUCTIONS AND PRECAUTIONS.

---

## 3 - INSTALLATION AND START-UP

---

### 3.1 INSPECTION

1. When the unit arrives, check immediately for signs of shipping damage. If you do notice any damage, report it to the trucking company right away.
2. Remove the cover on the front of the unit, as shown in Fig. 1-4. Check the following items:
  - Remove the packaging restraints.
  - Be sure the HoneyCombe® wheel is in position.
  - Check the position of the drive belt. The belt should be in good contact with the sheave.
  - Be sure the drive belt and rollers are free of grease.
  - Be sure the HoneyCombe® wheel can be turned by hand with some resistance with the belt removed.
  - Ensure that the process and reactivation air filters are in place.

### 3.2 POSITIONING THE UNIT

1. Figure 3-1 shows the dimensions of the HC-300 unit. You must allow three clearances around the unit:
  - a 24" space in front of the unit so you can remove and replace the HoneyCombe® wheel
  - a 12" space in front of the process air intake to allow smooth air flow (not necessary if ductwork is installed)
  - a 12" space in front of the reactivation air intake to allow smooth air flow (not necessary if ductwork is installed)

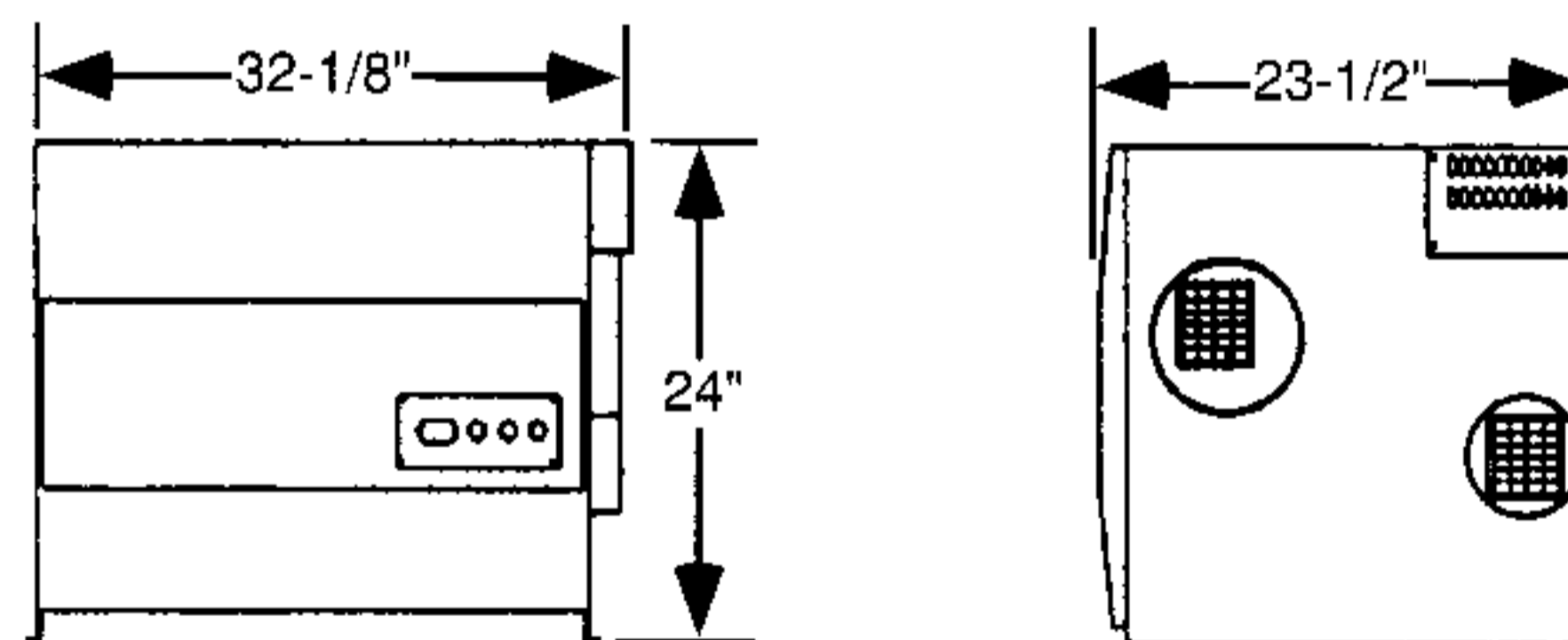

FIGURE 3-1  
DIMENSIONS

2. Figures 3-2, 3-3 and 3-4 show three different ways of installing the HC-300.
3. There are some simple rules for arranging the ductwork for the HC-300:

Process air intake	Taken from the storage space
Process air outlet	Vented to the storage space
Reactivation air inlet	Taken from a separate space (not from storage space – don't use dehumidified air)
Reactivation air outlet	Vented outdoors (air is very damp - don't use for space heating)

(Note – The reactivation air can also be taken from and returned to an indoor space where the temperature and humidity levels are not important.)

4. Wherever the intake or outlet ducts open outdoors, protect them from the elements. Install weather hoods and bird screens.
5. Do not locate the intake and outlet for the process air too close together. If possible, allow a distance of at least 5 feet. Allow the same distance between the inlet and outlet for the reactivation air.
6. Figure 3-4 shows the set-up if you are installing the HC-300 in a system with an existing air-handling unit. Notice that both sides of the HC-300 are connected upstream of the air-handling unit.

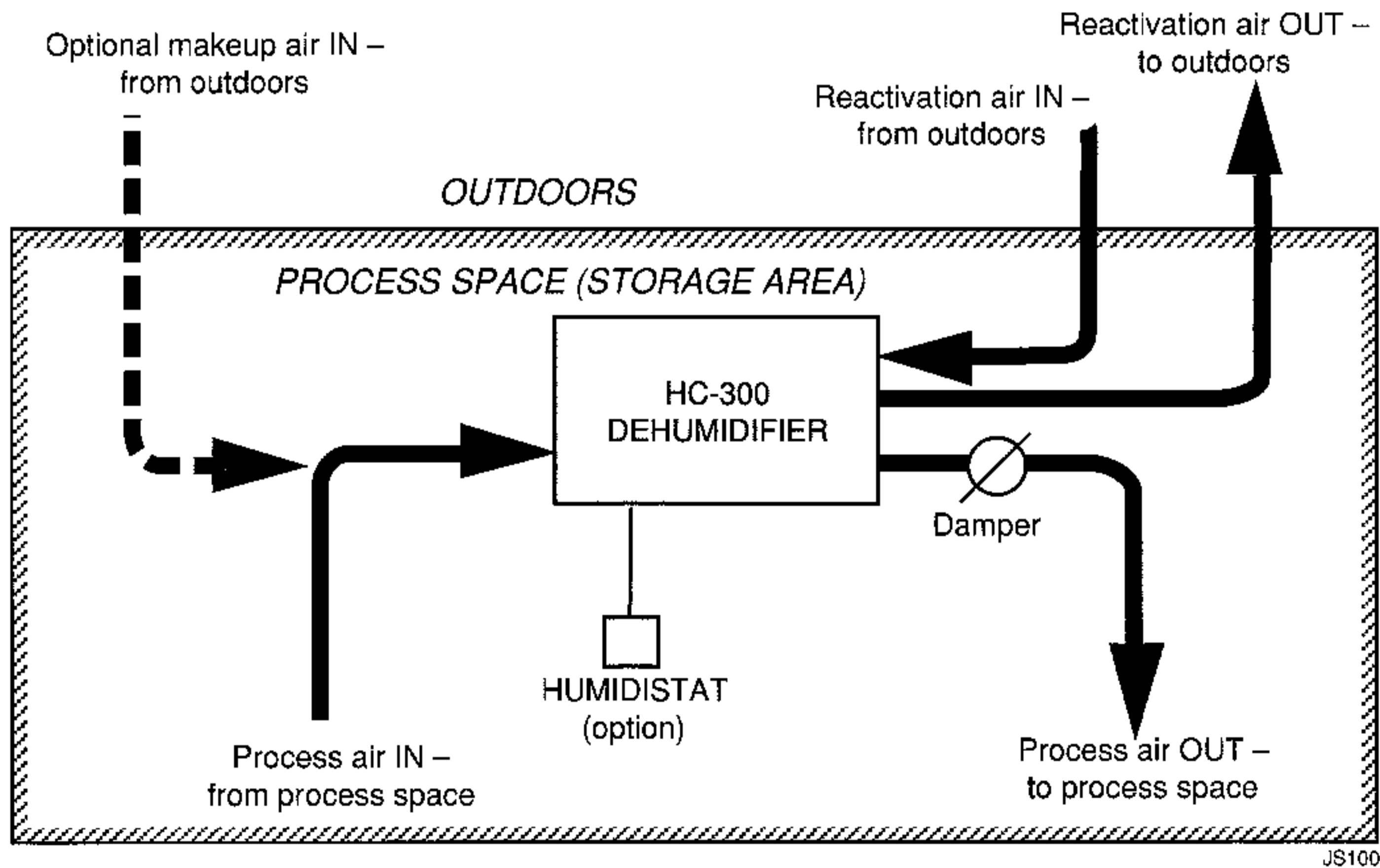

FIGURE 3-2  
HC-300 INSTALLED IN PROCESS SPACE

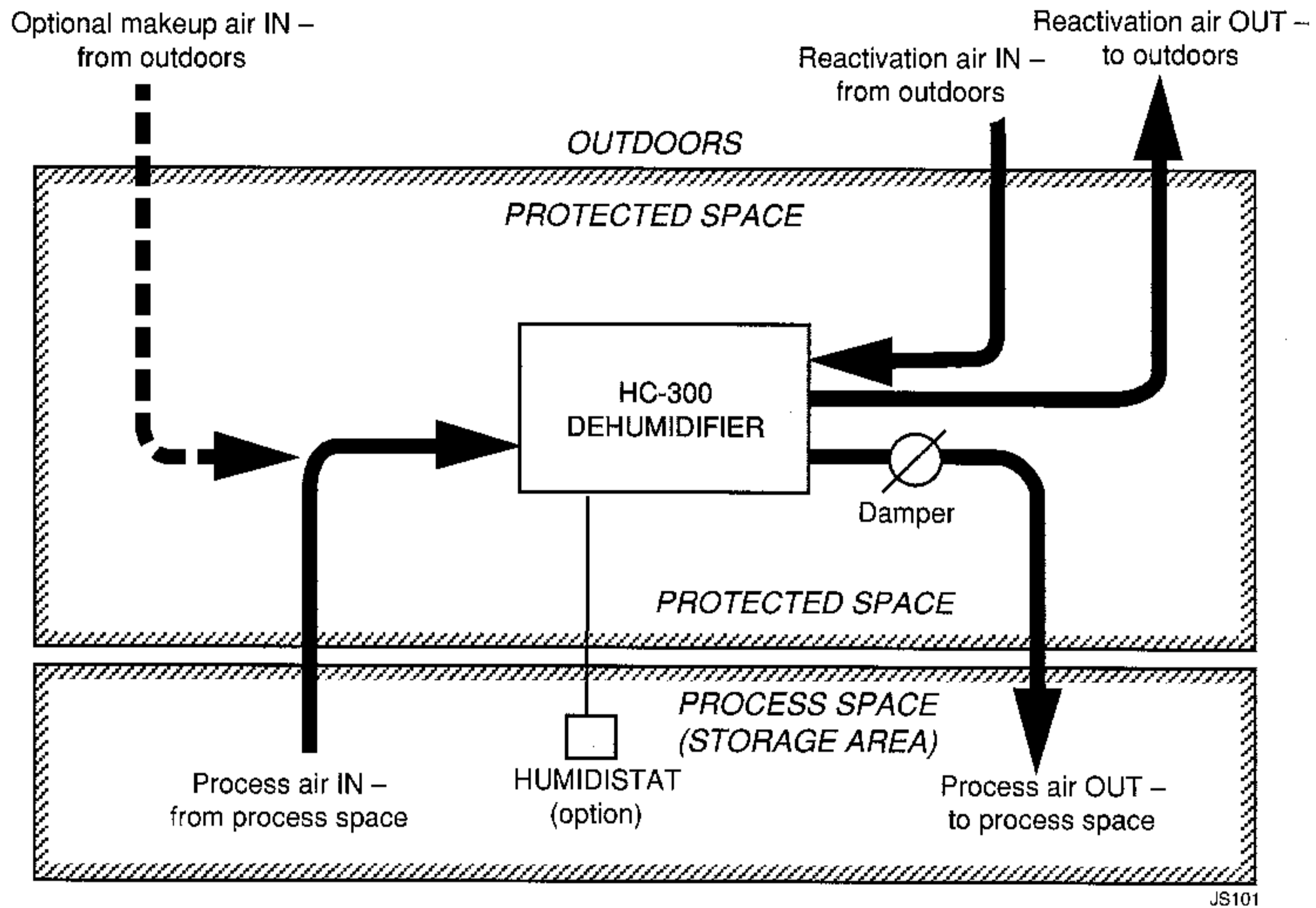

FIGURE 3-3  
HC-300 INSTALLED OUTSIDE OF PROCESS SPACE

Do not connect the HC-300 so that it bypasses the air-handling unit. See Part A of Fig. 3-5. If you connect the ductwork this way, some of the air from the air-handling unit may be forced back through the HC-300, and the HC-300 will not be able to work correctly.

You may connect both sides of the HC-300 downstream of the air-handling unit, as shown in Part B of Fig. 3-5. The arrangement shown in Fig. 3-4 is better, however. This set-up allows the air-handling unit to heat or cool the processed air after it leaves the HC-300.

7. On some installations, "makeup" air is taken from outside the process space, and added to the process air stream. Unconditioned makeup air can add a moisture load to the HC-300, and this can overload the unit. For recommendations, consult the Service Operations Department at Munters.

### 3.3 CONNECTING THE DUCTWORK

1. Don't try to operate the unit without ductwork. The unit will not be damaged, but it will not operate correctly without the proper ductwork in place. Figures 3-2, 3-3 and 3-4 show some correct installations. Before you install the ductwork, remove the finger guards from the duct openings.

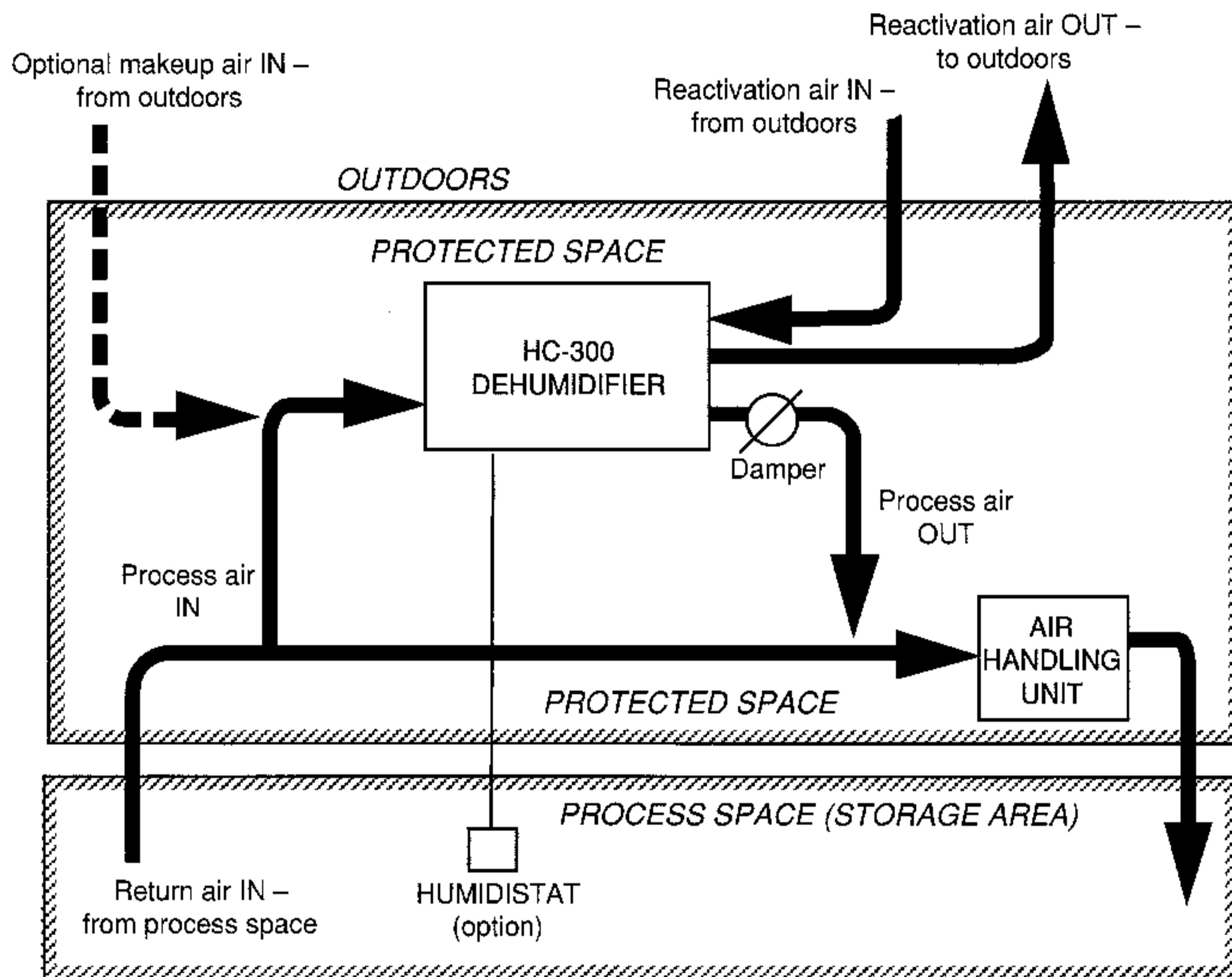

JS102

FIGURE 3-4  
HC-300 INSTALLED WITH EXISTING AIR-HANDLING UNIT

2. Here are details on the duct connections:

Process intake	if no ducting – allow 12" clearance optional fitting for 8" round ductwork is available
Process outlet	connection to 8" round ductwork add damper downstream of outlet
Reactivation intake	if no ducting – allow 12" clearance optional fitting for 6" round ductwork is available
Reactivation outlet	connection to 6" round ductwork

3. The ductwork for the reactivation air outlet should always be insulated. This will reduce condensation of the moisture in this air stream. Run the reactivation ductwork so that it slopes away from the dehumidifier. This way any condensed moisture will run away from the dehumidifier. On this type of installation, the unit should be installed at least 3 feet above the floor to allow for the slope in the ductwork.

If it is not possible to do this, include a vertical section in the ductwork, connected to the unit via a Tee fitting. Any moisture will collect in the part of the ductwork below the Tee connection. Install a "P" trap to allow a way of draining the moisture.

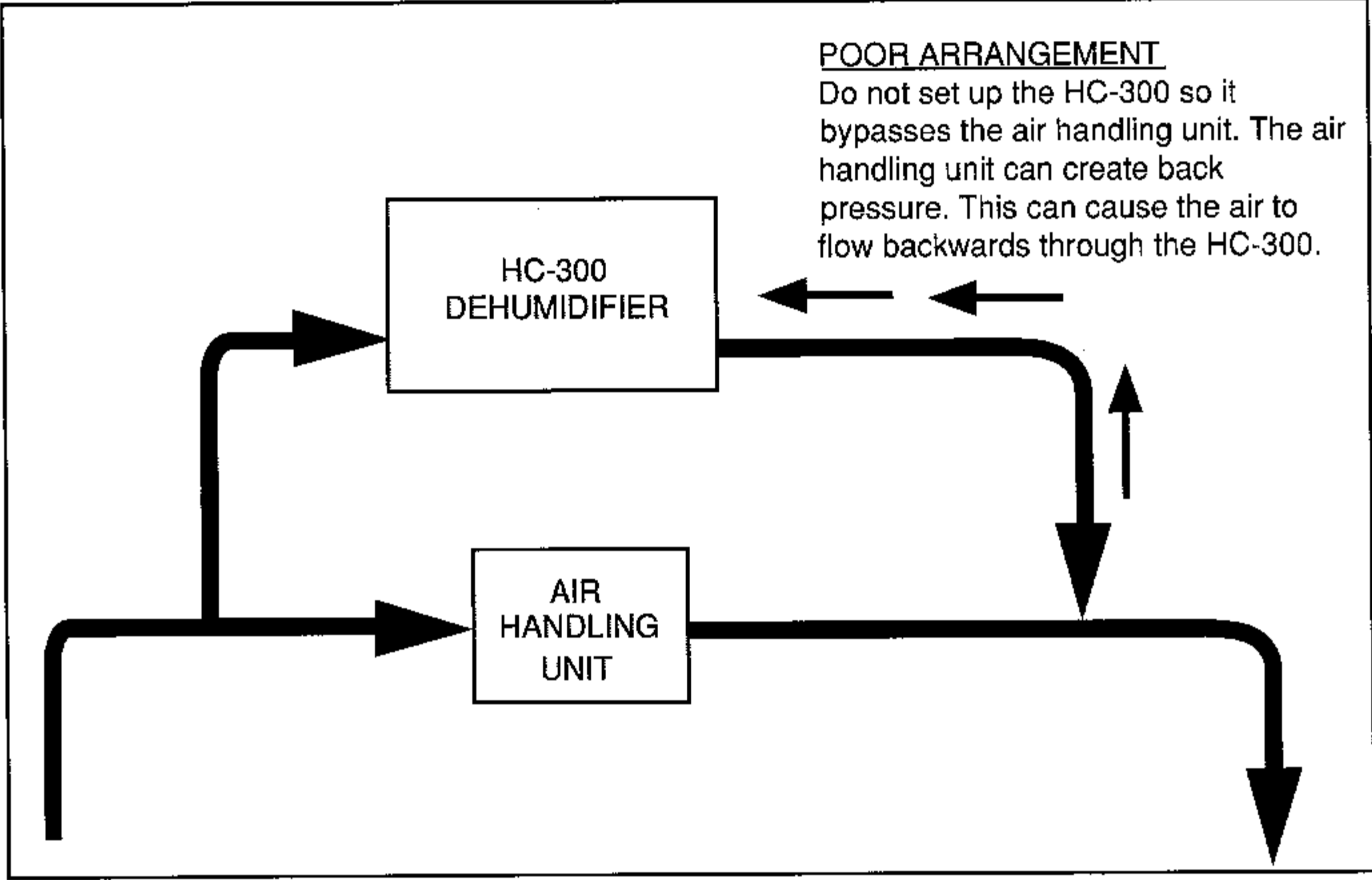

PART A

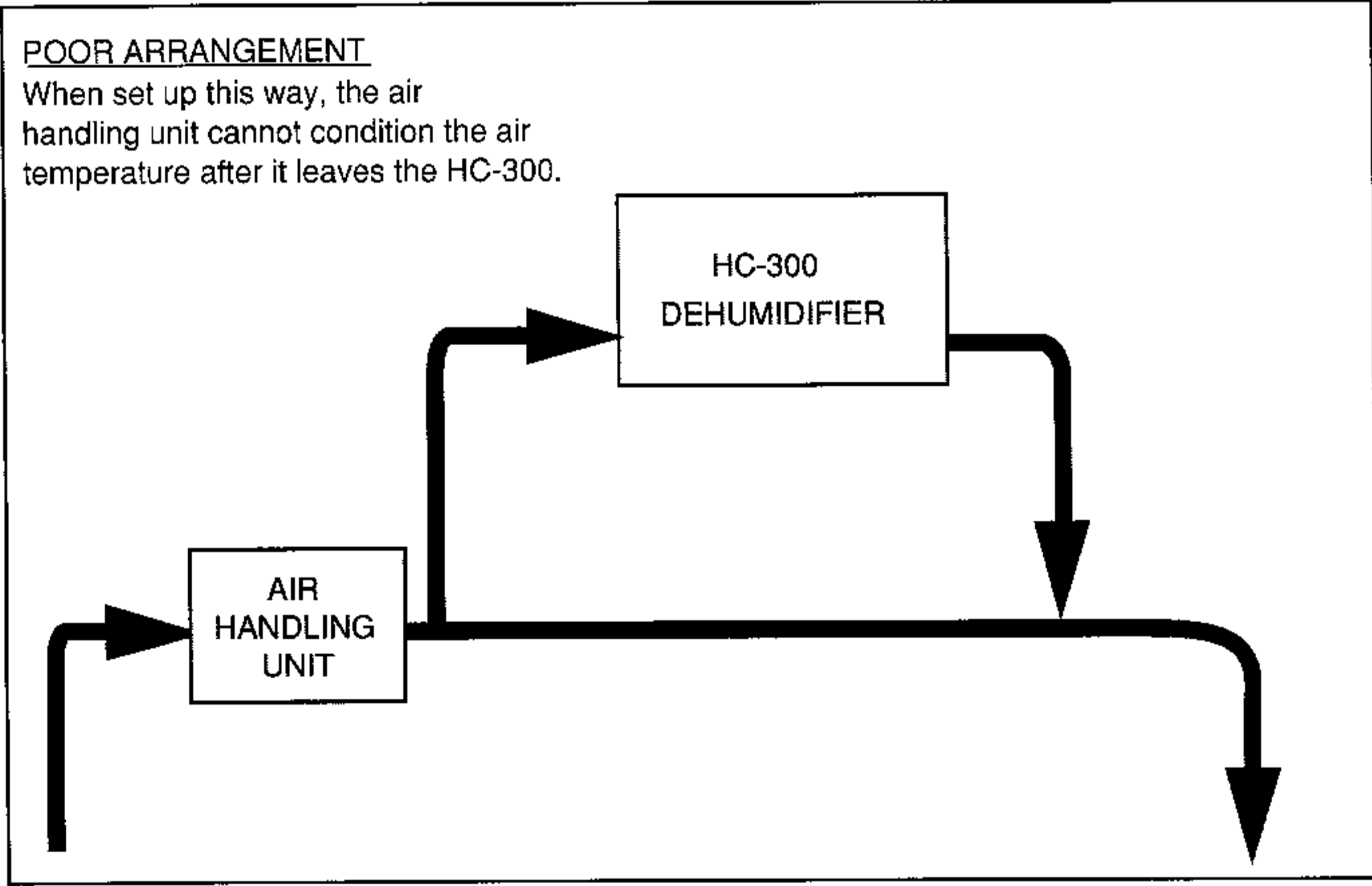

PART B

JS103

FIGURE 3-5  
DO NOT INSTALL HC-300 THIS WAY

---

### 3.4 ELECTRICAL CONNECTIONS



**Electrical connections should only be made by a licensed electrician.**

1. The HC-300 is designed to operate on single-phase or three-phase AC at 208 to 480V. (Check the nameplate in the unit for the correct voltage and phase.) The customer must provide a disconnect switch on the AC line.
2. Open the front cover of the unit so you can make the wiring connections. Make the AC connections to the "line" side of the circuit breaker.
3. Be sure the chassis of the HC-300 is connected to a good earth ground.
4. Turn on the disconnect switch, and turn on the circuit breaker inside the machine. Open the damper for the process air. To start the unit, set the Auto/Off/Manual switch to the Manual position. Open the front cover and check the rotation of the HoneyCombe® wheel. The wheel should start turning clockwise (when seen from above the wheel).

### 3.5 CONNECTING THE REMOTE HUMIDISTAT



**Electrical connections should only be made by a licensed electrician.  
Check all connections for tightness after 60 days of operation.**

1. In some installations, the HC-300 operates in the manual mode. In this type of installation, the HC-300 operates whenever the Auto/Off/Manual switch is set to Manual. Other units are set up for automatic cycling. In an installation of this type, the HC-300 is controlled by a device called a humidistat. The humidistat works much like the thermostat in a home heating system. When the humidity rises above a pre-set point, the humidistat turns on the HC-300.
2. The humidistat should be designed to operate at 24 V AC. Use a "close on rise" humidistat, with contacts which are normally open. (The contacts should be open when the humidity is below the pre-set limit, and closed when the humidity is too high.) The humidistat contacts should be rated at 1 Amp.
3. Mount the humidistat in the space you want to dehumidify. For best results, place the humidistat near the inlet duct for the process air. This will provide the most accurate sensing of the relative humidity in the process space. If possible, mount the humidistat away from the floor and ceiling, and do not mount it near any doors and windows. Do not mount the humidistat near the outlet vent for the process air from the HC-300.
4. Make the wiring connections between the humidistat and the HC-300 using 24 AWG wire. **Before you do this, turn off the power to the unit!** The humidistat should be wired to the plug connector on the side of the unit. See the wiring diagram for the i.d. numbers of the plug terminals.

---

### 3.6 ADJUSTING THE DAMPER

1. As shown in Fig. 3-2, 3-3 or 3-4, you should install a damper in the outlet duct for the process air stream.
2. Figure 1-4 shows the control knob on the power controller for the heaters (SSP1) This should be set for 120°F.
3. Turn on the unit by setting the Auto/Off/Manual switch to the Manual position. Allow the unit to warm up for 1/2 hour. Check the temperature at the reactivation outlet. It should be 120°F ±5°F.
4. Close the process damper completely. Wait ten minutes for the temperatures in the machine to stabilize, then check the temperature at the reactivation outlet. The temperature here should now be higher than 120°F.
5. Now open the damper a bit and wait ten minutes before checking the reactivation outlet temperature again. You should see that it has dropped a bit. Continue opening the damper by small amounts and checking the temperature. Eventually you will find a setting which causes the reactivation outlet temperature to drop to 120°F. This is the correct setting for the process damper.

---

## 4 - PREVENTIVE MAINTENANCE

---

The HC-300 unit requires very little regular maintenance. Check these points every 30 days:

### 4.1 CLEAN THE AIR FILTERS

1. The HC-300 unit includes two air filters. These are shown in Fig. 1-4. Each filter is made of expanded aluminum, mounted in a metal frame.
2. Switch the unit off and wait for the blowers to stop turning. Open the front access panel. The process filter is located in the lower left hand corner of the unit.
3. The reactivation filter is mounted on the right end of the unit. See Fig. 1-4. Undo the two thumbscrews on the bottom of the case. Using the tab, pull the bottom of the filter outward, then down.
4. If necessary, clean each filter in warm soapy water. Allow each filter to air-dry, or use compressed air. Once the filters are dry, re-install them by reversing Steps 2 and 3 above.

### 4.2 CHECK THE HONEYCOMBE® WHEEL

Check the HoneyCombe wheel to be sure it is rotating correctly. Look for signs of discoloration caused by dirt, dust, or other foreign materials. In order to clean the wheel and inspect the seal, you must remove the drive motor and wheel. See the instructions in Section 5.10, Checking the Drive Motor, Wheel and Seals.

### 4.3 CHECK THE UPPER AND LOWER AIR SEALS

The HoneyCombe® wheel rides on the lower air seal. Make a quick check of this seal. Be sure the outer surface of the seal is smooth. If the seal is very worn, the outer layer will wear through. If the seal must be replaced, please contact the factory.

### 4.4 CHECK THE REACTIVATION OUTLET TEMPERATURE

After the unit has been operating for 30 minutes, the temperature at the outlet of the reactivation air stream should be about 120°F. Check this outlet temperature with a thermometer. It should be within  $\pm 5^\circ\text{F}$ . If the outlet temperature falls outside this range, see the section on "Troubleshooting."

---

## 5 - TROUBLESHOOTING

---

The HC-300 has a state-of-the-art design, with a sophisticated control system using solid-state electronics. The technology used in this unit has proven to be very reliable in a wide variety of installations. When service problems do occur, they are often caused by the installation, rather than the HC-300 unit itself.

There are two parts to this section of the manual. In the first part, we will list some of the trouble symptoms you may find, and tell you how to correct them. In the second part, we will list some specific service routines – how to replace the HoneyCombe® wheel, how to check the heating elements, etc.

### 5.1 POSSIBLE TROUBLE CONDITIONS

In order to check most of these trouble conditions, the HC-300 must be turned on and operating, or trying to operate. Some units are wired with remote humidistats. With this type of set-up, it is sometimes not clear whether the humidistat is trying to turn on the HC-300. If you want to be sure the HC-300 is ready to operate, turn the Auto/Off/Manual switch to the Manual position.

### 5.2 AUTO/OFF/MANUAL SWITCH IS SET TO AUTO, RUNNING LIGHT DOES NOT COME ON



**This service procedure involves an electrical hazard. Service work should only be done by an electrician who has been qualified by Munters.**

1. Be sure the unit is receiving power. Check the circuit breaker or fuse which supplies the unit. The unit also has an internal circuit breaker behind the front cover.
2. There may be a problem with the humidistat. Set the Auto/Off/Manual switch to Manual. Does the wheel start to turn?
3. If the HC-300 starts to operate, check the humidistat. For some reason, the humidistat is not starting the HC-300. (The humidistat is bypassed when you set the switch to the Manual position.) Either the humidistat is not working, or the signal is not reaching the HC-300. See the section on "Checking the Humidistat."
4. Check the small fuses on the circuit boards inside the unit.

### 5.3 FAULT LIGHT IS ON, AND MACHINE SHOULD BE RUNNING

(Auto/Off/Manual switch is set to Auto or Manual)



**This service procedure involves an electrical hazard. Service work should only be done by an electrician who has been qualified by Munters.**

- 
1. The Fault light is triggered when the heating elements overheat. There can be several possible causes. Begin by checking for a blockage in the reactivation air stream. Once the unit cools down, you may be able to reset it by turning the Auto/Off/Manual switch to Off, then back to Auto or Manual. You should still check the installation carefully for any possible problems.
  2. The heating elements may also overheat if the AC line voltage rises much above the specified AC voltage. The line voltage should be within  $\pm 10\%$  of the specified voltage.
  3. If the reactivation blower is overloaded, it will stop automatically. This may cause the heater to overheat, and trip the Fault light. Once the motor has cooled, it should restart automatically.

During the overheat condition, the fusible links on the heating elements may open. When the unit restarts, you may find that there is no reactivation heat. See the section on "Checking the Heating Elements."

4. The thermistor for the solid-state power controller (TSE1) may be bad. See the section on "Checking the Thermistors."

#### 5.4 REACTIVATION OUTLET TEMPERATURE IS TOO LOW

1. The air at the outlet for the reactivation air should be about 120°F,  $\pm 5^\circ$ . This measurement gives you a way of making a quick check of the overall operation of the HC-300.
2. The temperature may be too low if you try to operate the HC-300 without any ductwork. This can allow too much process air through the unit. See the material on "Adjusting the Damper" in the section on "Installation and Start-Up."
3. If the unit is overloaded, and is trying to remove too much moisture, the temperature at the outlet will drop below 120°. (You can think of the excess moisture as "cooling off" the stream of heated air.) Is there some reason why the air in the system has suddenly become much more humid? This change could be overloading the HC-300.
4. You can see a similar problem if the unit is trying to handle too much of the damp air at once. The volume of process air (the "process volume") may be too great. Change the volume of process air by adjusting the damper. Turn the HC-300 on and allow it to warm up. Check the **reactivation** outlet temperature – it should still be low. Close the process damper completely, then wait about 10 minutes for the temperatures and air volumes in the HC-300 to stabilize. Check the reactivation temperature again. It should be quite a bit higher than 120°F. Now open the damper a bit, wait another 10 minutes, and check the outlet temperature again. Keep doing this until you find the process damper setting which causes the reactivation outlet temperature to drop to 120°F. This is the correct setting for the process damper.
5. One of the heating elements may have stopped working. See the section on "Checking the Heating Elements."

- 
6. A low outlet temperature can also be caused by a problem with the reactivation blower. Turn off the HC-300 and try to spin the blower by hand. It should turn freely.
  7. There may be a problem with the thermistor which controls the solid state power control (TSE1) See the section on "Checking the Thermistors." There may also be a problem with the power control itself (SSP1) Substitute a new part.

### **5.5 POOR DEHUMIDIFYING PERFORMANCE**

1. Check the two intake filters, shown in Fig. 1-4. If these filters are dirty, clean them as described in the section on "Cleaning the Air Filters."
2. If you have installed bird screens on the intake and outlet for the reactivation air, check these.
3. Has something changed in the process space which could increase the moisture load on the unit? Check all openings into the process space to be sure all doors and windows are closed. Check for leaks in the ductwork.
4. The volume of process air may be too great. You can reduce the volume of process air by closing the process damper. (The control system will sense the changing conditions in the stream of process air, and make adjustments to the temperature and volume of the reactivation air.)
5. Check the air temperature at the outlet for the reactivation air. It should be 120°F,  $\pm 5^\circ$ . If it is not, see the section on "Reactivation Outlet Temperature is Too Low."
6. One or more of the heating elements may not be working. See the section on "Checking the Heating Elements."
7. If the process blower is overloaded, it will shut down automatically. This will prevent the unit from drying the process air. The motor will restart automatically, once it has cooled.
8. The HoneyCombe® wheel may be stopped. See the next section.

### **5.6 HONEYCOMBE® WHEEL IS STOPPED, RUNNING LIGHT IS ON**

1. Check the wheel drive system. See Fig. 1-4. Pull back on the tensioner to loosen the belt. Remove the belt from the drive wheel on the motor. Set the Manual/Off/Auto switch to the Manual position to turn on the unit. The drive motor should turn slowly. See section 5.10, Checking the Drive Motor, Wheel and Seals.
2. After long use, the lower seal may wear. The HoneyCombe® wheel will then ride on the inner layer of the seal material. Since this is not as slippery as the outer layer, the wheel will not turn easily. Check the condition of the lower seal. The surface of the seal should be smooth. If the seal is very worn, you will be able to see some of the inner layer of seal material. If the seal must be replaced, please contact the factory for instructions.

---

## SERVICE ROUTINES –

### 5.7 CHECKING THE HEATING ELEMENTS



**This service procedure involves an electrical hazard. Service work should only be done by an electrician who has been qualified by Munters.**

1. The heating elements are located near the intake for the reactivation air. See Fig. 1-4.
2. To check the elements, turn off the power to the unit! Remove the inlet grill for the reactivation air.
3. Check the resistance across each of the heating elements using an Ohmmeter. The resistance across each element should be 16Ω to 75Ω. Take your measurements at the incoming wire leads. If you find an infinite resistance, the element has developed an "open circuit," and must be replaced. A faulty heating element assembly must be replaced as a unit.
4. Each of the power wires for the elements includes a fusible link. Once one of these links opens, it will cut off power to the element. Check across each fusible link with an Ohmmeter. A failed link will appear as an open circuit.
5. Check for a problem with the thermistor (TSE1) for the power controller (SSP1) If this thermistor open-circuits or shorts, the SSPC will not produce any output for the heating elements. Substitute a new part.

### 5.8 CHECKING THE THERMISTOR

1. A thermistor is a type of temperature sensor. This unit has one thermistor to sense the temperature of the heating elements (TSE1). The thermistor sends a signal to the solid-state power controller (SSP1), which controls the heaters. A thermistor may fail in either a shorted or an open-circuit condition. If the thermistor shorts **or** open-circuits, the power controller will shut off, and the heaters will not operate. Because of the way the thermistor operates, it is difficult to check it with a volt-ohmmeter. Often the easiest way to diagnose a problem is to substitute a new part.

### 5.9 CHECKING THE HUMIDISTAT

1. Start by adjusting the humidistat to the high end of the scale (close to 100% relative humidity). At this point, the humidistat should not be calling for drying. The contacts inside the humidistat should be open, and you should be able to measure 24 V AC across the contacts.
2. Next, adjust the humidistat to the low end of the scale (close to 10% or 20% relative humidity). Now the humidistat should be calling for drying, and the contacts inside the humidistat should be closed. You should see 0 Volts across the contacts.

- 
3. You can also check the wiring between the humidistat and the HC-300. The humidistat is connected to terminals on the printed circuit board. When the humidistat is not calling for dehumidification, you should see 24 V AC across the contacts.

#### **5.10 CHECKING THE DRIVE MOTOR, WHEEL AND SEALS**

1. Before you can remove the wheel, you must remove the drive motor. Figure 1-4 shows the drive wheel and belt.
2. Pull back the tensioner to loosen the drive belt. Remove the belt from the drive sprocket on the motor.
3. Unplug the wiring connections to the drive motor. Be careful not to pull too hard on a connector. This could damage the wiring or the circuit board.
4. Remove the motor and drive assembly. This is mounted on the right-hand roller wheel assembly.
5. Remove the small roller wheels which are located on each side of the HoneyCombe® wheel. To remove a roller wheel, lift the wheel shaft up. Pull the bottom of the shaft toward you, then down.
6. Gently lift the wheel a bit and pull it forward. Be careful not to damage the lower seals.
7. The small passages in the HoneyCombe® wheel may be plugged by dust or dirt. To inspect the passages, hold the wheel upright. Hold a lamp with a 60 watt bulb behind the wheel. If the passages are clear, the light from the lamp should shine through the wheel. Because the passages are so small, you won't be able to see the light directly. Instead, you should see the glow from the light. If any part of the wheel is plugged, you will see a dark area.
8. If the wheel seems to be plugged, it may be possible to clean it. Use a wet/dry vacuum, and a dusting brush attachment with a soft bristle brush. Vacuum both surfaces of the wheel.
9. If you cannot clear the wheel using the vacuum, you may use compressed air to help the process. You must do this carefully, so that you do not damage the wheel. The compressed air should be dry and free of oil. Don't use a pressure higher than 30 PSIG. Use the compressed air on one side of the wheel, and the vacuum on the other. Don't hold the compressed air hose closer than 12" to the face of the wheel.
10. This type of wheel is washable. It is best to clean the wheel using clean water only. If you must use a detergent, choose a mild type (enzyme or dish-washing detergent). The wheel is sensitive to high pH (alkaline condition). Choose a detergent which with a neutral pH. Do not use typical laundry detergents. Do not use any solvent to wash the wheel. This will permanently damage the wheel.
11. If the wheel is still plugged, or if the honeycomb structure has softened, please call the Service Operations Department at Munters.
12. To replace the wheel, reverse Steps 2 through 6 above.



**Munters Corporation**  
Dehumidification Division — Industrial  
79 Monroe Street, P.O. Box 640  
Amesbury, MA 01913-0640  
TEL: (978) 241-1100 or (800) 843-5360  
FAX: (978) 241-1217  
WWW: <http://www.muntersamerica.com>  
e-mail: [dhinfo@munters.com](mailto:dhinfo@munters.com)



REVISED	DESCRIPTION	DATE	BY	APP
1	REVISED TO SHOW NEW CONTROL PANEL	4/95	GS	EL
2	UPDATED TO NEW BORDER	12/29/98	TAB	EL
3	ADDED PAGE 2 WORKING LUG NOTE & 23-04 DIA. WEIGHT WAS 300 LBS.	04/06/05	800	EL
4	REVISED -02 PER AS BUILT	4/15/05	L.M.	EL
5	DELETED PAGE 2	2/29/08	800	EL

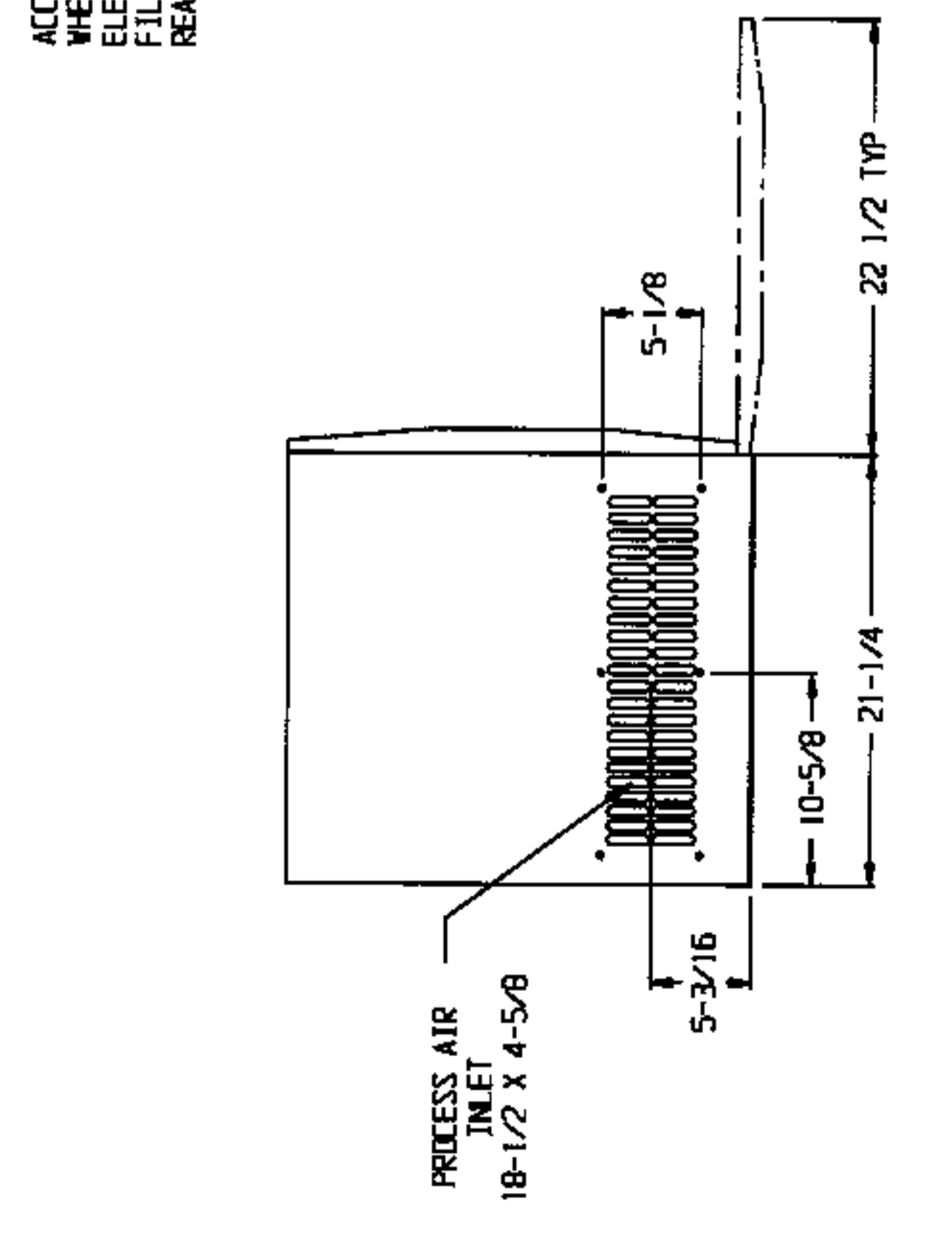
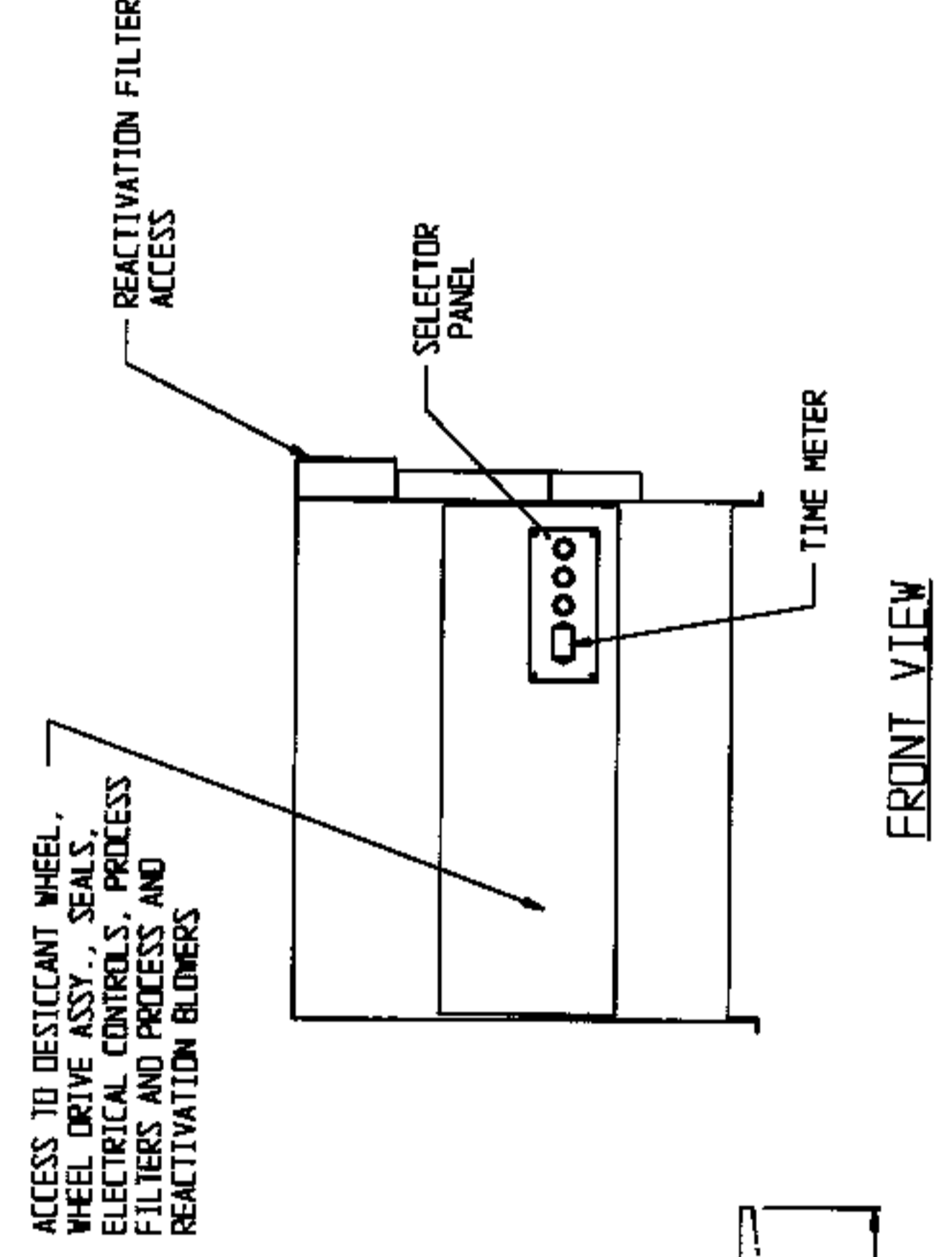
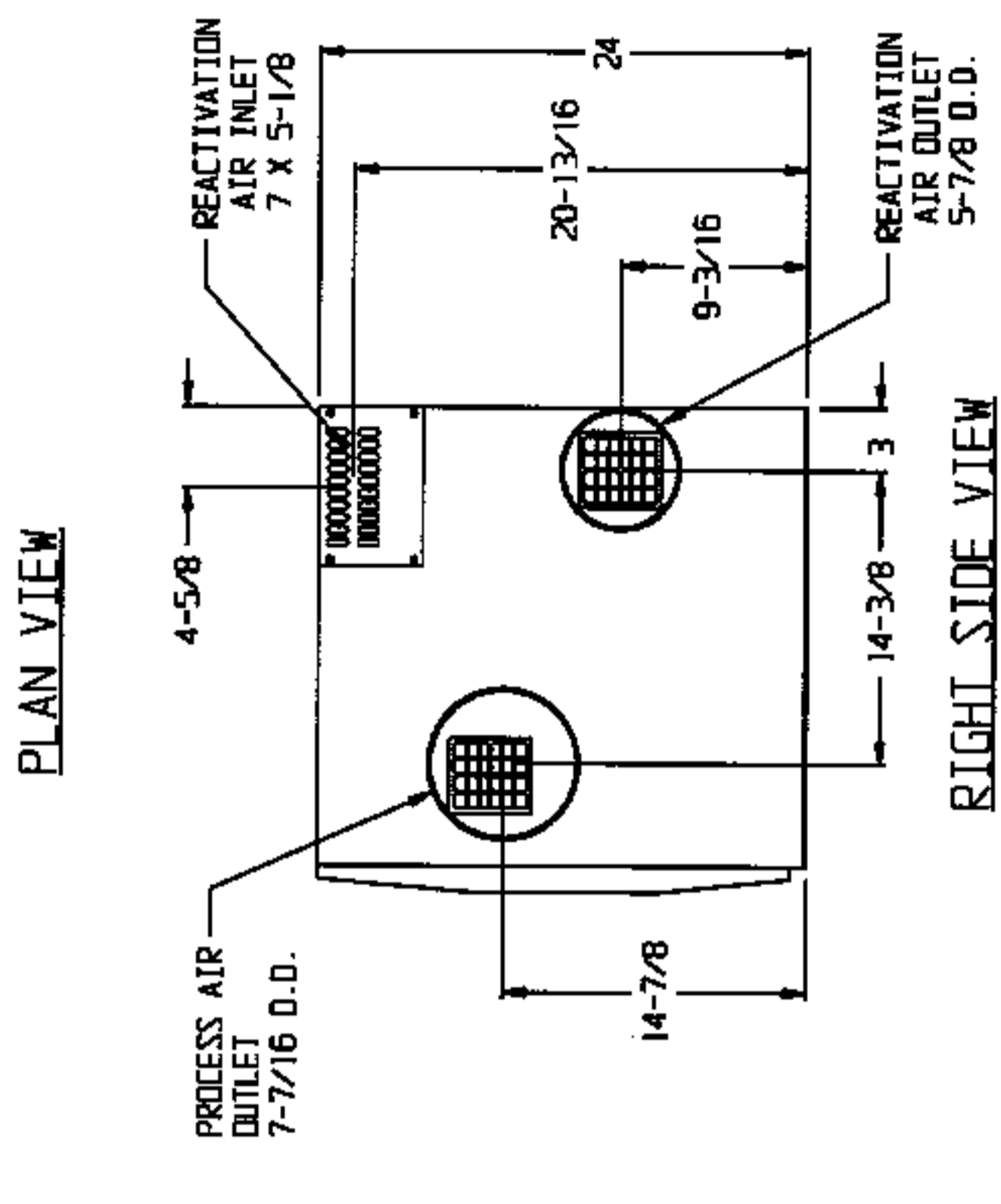
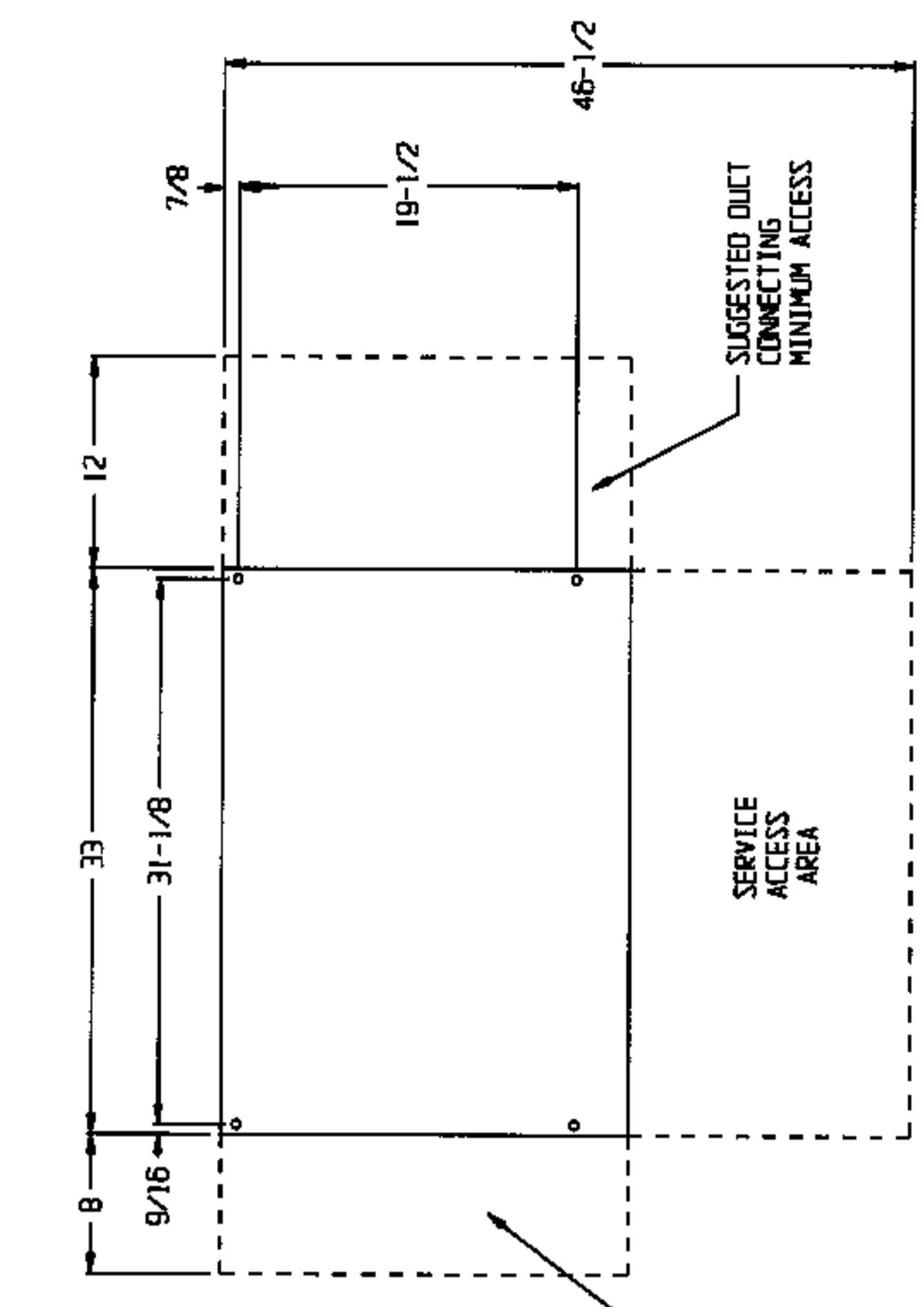
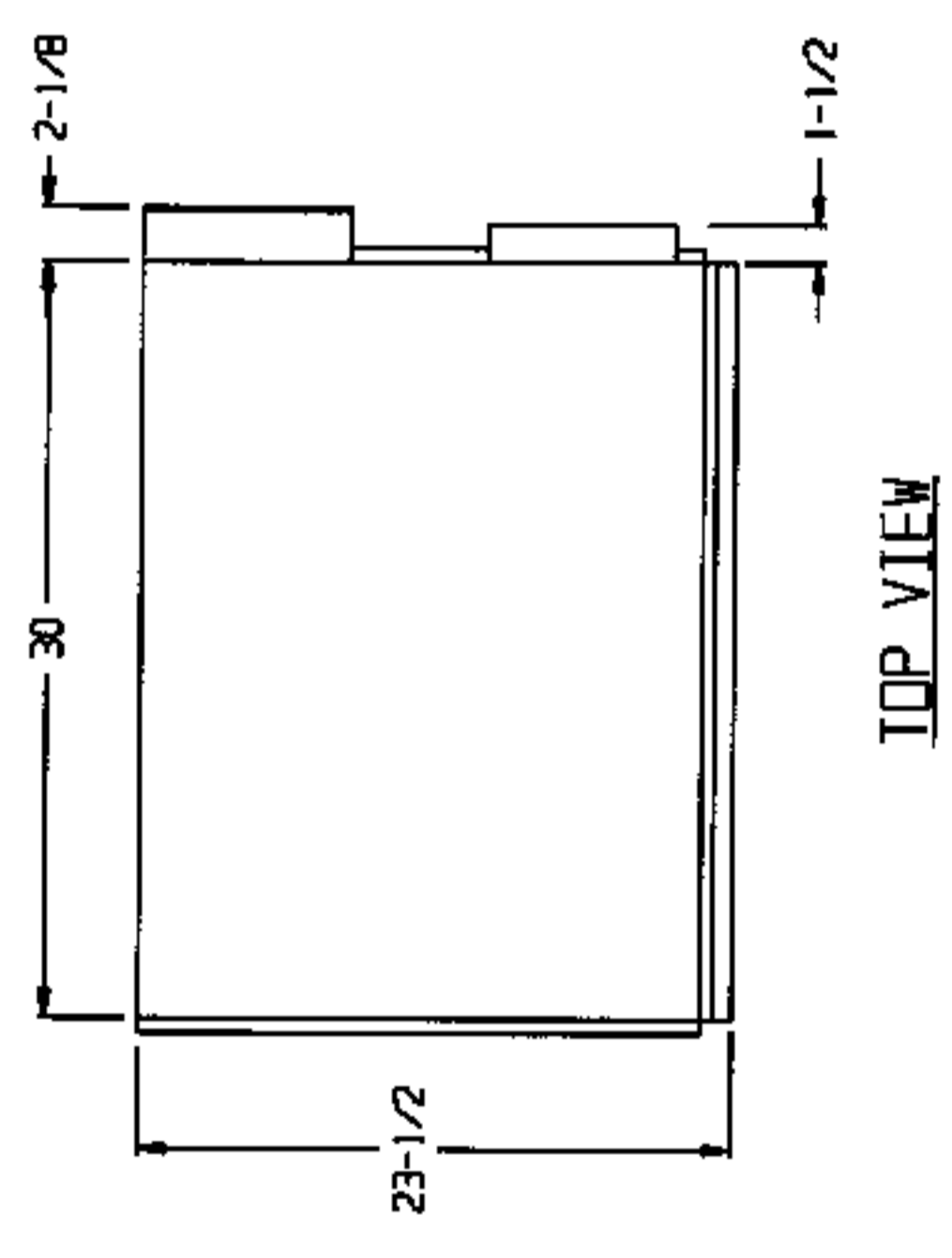

**CONFIDENTIALITY STATEMENT**  
 THE TECHNICAL INFORMATION AND DESIGN DATA DISCLOSED HEREIN CONSTITUTE PROPRIETARY INFORMATION OF MUNTHERS CARQUECOIRE. IT IS TO BE MAINTAINED IN STRICT CONFIDENCE. THIS INFORMATION IS FOR THE SOLE USE OF OUR CUSTOMERS AND END USERS OF OUR EQUIPMENT.

Part No. 30561  
 Date: 11/22/93  
 Designer: G.N.G.  
 Checker: KHY  
 Date: 11/22/93  
 Title: GENERAL ASSEMBLY  
 Part No.: HC-300

Munters Carquecoire  
 79 Marce St. Jersey, NJ 08913  
 TEL: 908-241-1100 FAX: 908-241-1214

Sheet: 1 of 1  
 Size: B  
 Part No.: 74119-5

PART NO. 74119-01

ESTIMATED WEIGHT - 150 LBS.

Rev	Description	Date	Dft	Chk	App
0	SAME 50191R2 W/O FAN SPEED CONTROL.	10/97	YL	EAC	EAC
1	UPDATED DRIVE MOTOR TO BODINE	01/09/01	CJT	EAC	EAC
2	ADDED TB03, TB06	01/02/02	EAC	KPW	EAC
3	CHANGED FU01 FROM 10 TO 4 AMPS	9/3/03	GJM	KPW	GJM
4	NOTE 10 WAS #22 AWG	6/12/07	TLB	KPW	TLB
5	ADDED FUSE LIST, FUSIBLE LINKS REMOVED FAN SPEED CONTROL SETTINGS AND CORRECTED NOTE 10	4/1/08	TLB	KPW	TLB
6	CONN WAS A 3 POLE WITH AUX CONTACT	7/16/08	TLB	CAG	TLB
7	CHANGED HS01 CONTACT DESCRIPTION	7/1/09	MLJ	RDS	RDS
8	UPDATED NOTE 4	7/17/13	DSL	RDS	RDS

- PRINTED CIRCUIT BOARD POWER. FOR 115VAC JUMPER W3 1 TO 2 AND W2 1 TO 2. FOR 220VAC JUMPER W1 1 TO 2 ONLY.
- COMPONENTS SHOWN DOTTED ARE AVAILABLE AS OPTIONS FROM C.E.C.
- ELECTRICAL COMPONENTS - REFER TO ELECTRICAL PARTS LIST.

SYM	DESCRIPTION	SYM	DESCRIPTION
LS	ROTATION LIMIT SWITCH (OPTIONAL)	LS	ROTATION LIMIT SWITCH (OPTIONAL)
CB	CIRCUIT BREAKER, MAIN LINE	MTR	MOTOR
CON	CONTACTOR, ELECTRIC HEATER	PB	PUSHBUTTON
DPS	DIFFERENTIAL PRESSURE SWITCH	PCB	PRINTED CIRCUIT BOARD
E	TERMINAL, SPADE TYPE	R	RED, INDICATOR LIGHT, FAULT
ETM	ELAPSED TIME METER	SSP	SOLID STATE POWER CONTROLLER
F	FUSE (PCB)	TB	TERMINAL BLOCK
FL	FUSIBLE LINK	TS	THERMOSTAT
FU	FUSE	TSE	THERMIST
G	GREEN, INDICATOR LIGHT, RUNNING	SS	SELECTOR SWITCH
HS	HUMIDISTAT	W	WHITE, INDICATOR LIGHT, POWER ON
HSP	HUMIDISTAT PLUG		
HTR	HEATER ELECTRIC, REACT. AIR		
J	JUMPER		

4. FOR ELECTRICAL WIRE SIZING DATA.  
A-STANDARD. AS75001  
B-CANADIAN. A72011

- PROTECTIVE DEVICES HAVE BEEN PRESET AND RECORDED AT FACTORY.
- EARTH GROUND IS TO BE INSTALLED (NOT BY C.E.C.) BEFORE ENERGIZING EQUIPMENT.
- BEFORE EQUIPMENT START-UP, REVIEW OPERATING AND MAINTENANCE MANUAL PROVIDED WITH UNIT.
- SEE ELECTRICAL PARTS LIST FOR COMPONENT SPECIFICATION.
- NC = NORMALLY CLOSED, NOF = OPEN ON FALL.  
NO = NORMALLY OPEN, OOF = OPEN ON RISE.
- ALL WIRING FROM J1 TO DEVICES IS TO BE #22 AWG.
- FUSIBLE LINK: PN#2329-01 (2) SPARES PROVIDED

**CONFIDENTIALITY STATEMENT**  
THE TECHNICAL INFORMATION AND DESIGN DATA DISCLOSED HEREIN CONSTITUTE PROPRIETARY INFORMATION OF MUNTERS CARGOCOIRE AND ARE TO BE MAINTAINED IN STRICT CONFIDENCE. THIS INFORMATION IS FOR THE SOLE USE OF OUR CUSTOMERS AND END USERS OF OUR EQUIPMENT.

Job No.	STD	Date	
Customer			
DrBy	Y.L.	10/97	
ClBy	BJK	10/97	
AppBy	BJK	10/97	
Scale	NTS	Sheet	1 of 1
Size	B	Part No.	50339
Rev	8	Wiring Diagram	DEW/HC-300
			208-240VAC 1Ø 50/60HZ

HC-300 PART NO. 50339-01  
DEW-300 PART NO. 50339-02

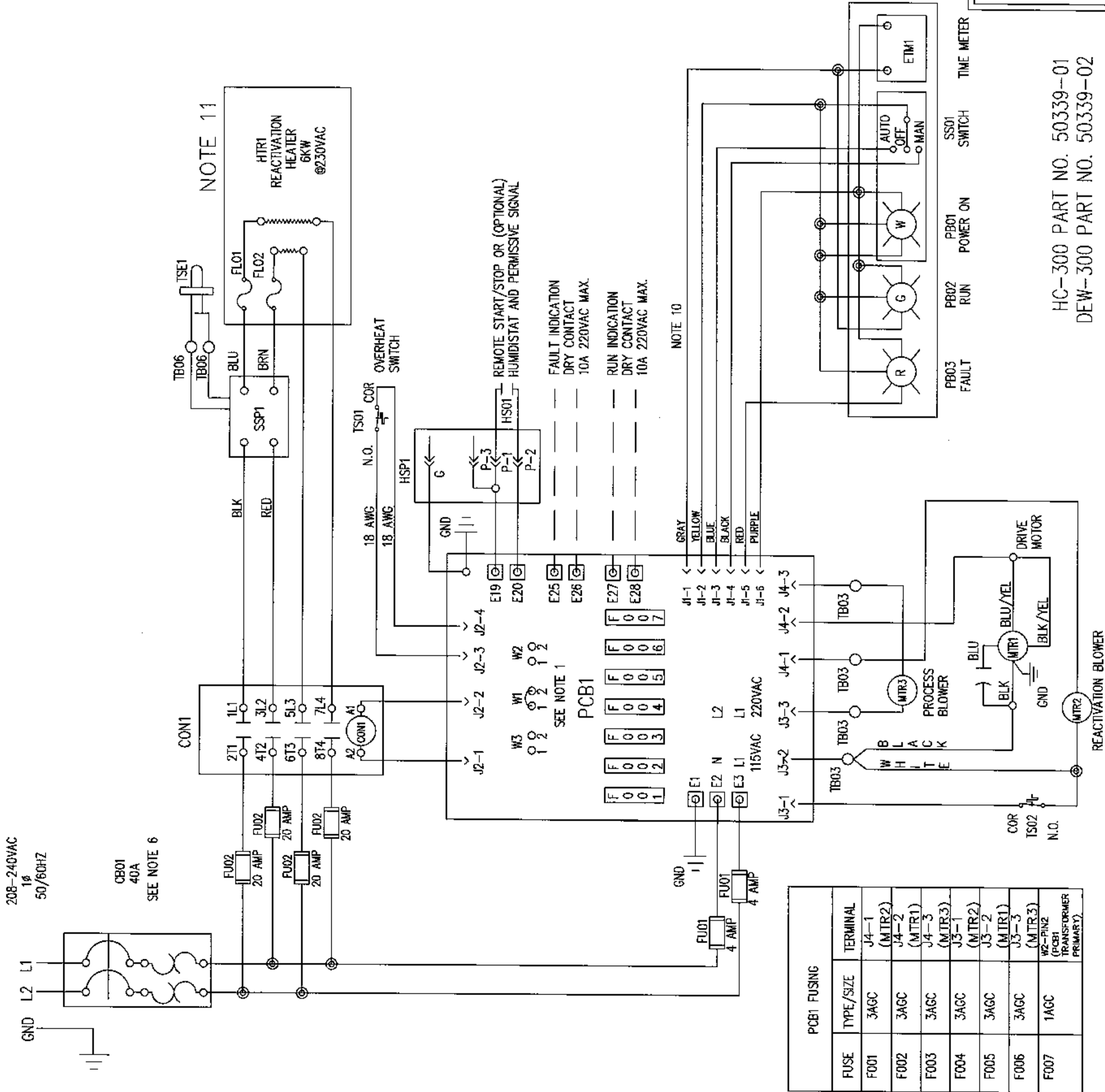

Rev	Description	Date	DR	CHK	APP
0	SAME AS 50192R2 W/O FAN SPEED CONTROL	10/97	YL	EAC	EAC
1	UPDATED DRIVE MOTOR TO BODINE	01/09/01	CJT	EAC	EAC
2	ADDED TB03, TB06	01/02/02	EAC	KPW	EAC
3	CHANGED FU01 TO 4 AMPS	10/28/03	KPW	CAG	CAG
4	CHANGED PRIOR TO WHITE	4/21/05	RSC	CAG	CAG
5	REMOVED OBSOLETE DIP SWITCH INFO AND ADDED PCB1 FUSE DETAILS	5/18/07	TLB	CAG	CAG
6	NOTE 10 WAS #22 AWG	6/12/07	TLB	CAG	TLB
7	ADDED NOTE 11, SYM FL & FIXED NOTE 10	4/1/08	TLB	CAG	TLB
8	ROOM WAS A 3 POLE WITH AUX CONTACT	7/16/08	TLB	CAG	TLB
9	CHANGED HS01 CONTACT DESCRIPTION	7/1/09	MAL	RDS	RDS
10	ADDED WIRE NUMBERS FROM CB01	1/29/10	MAL	RDS	RDS
11	UPDATED NOTE 4	7/17/13	DSS	RDS	RDS

1. PRINTED CIRCUIT BOARD POWER. FOR 115VAC JUMPER W3 1 TO 2 AND W2 1 TO 2. FOR 220VAC JUMPER W1 1 TO 2 ONLY.
2. COMPONENTS SHOWN DOTTED ARE AVAILABLE AS OPTIONS FROM C.E.C.
3. ELECTRICAL COMPONENTS - REFER TO ELECTRICAL PARTS LIST.

SYM	DESCRIPTION	SYM	DESCRIPTION
CB	CIRCUIT BREAKER, MAIN LINE	LS	ROTATION LIMIT SWITCH (OPTIONAL)
CON	CONTACTOR, ELECTRIC HEATER	MTR	MOTOR
DPS	DIFFERENTIAL PRESSURE SWITCH	PB	PUSHBUTTON
E	TERMINAL, SPADE TYPE	PCB	PRINTED CIRCUIT BOARD
ETM	ELAPSED TIME METER	R	RED, INDICATOR LIGHT, FAULT
F	FUSE (PCB)	SSP	SOLID STATE POWER CONTROLLER
FL	FUSIBLE LINK	TB	TERMINAL BLOCK
FU	FUSE	TS	THERMOSTAT
G	GREEN, INDICATOR LIGHT, RUNNING	TSE	THERMISTOR
HS	HUMIDISTAT	SS	SELECTOR SWITCH
HSP	HUMIDISTAT PLUG	W	WHITE, INDICATOR LIGHT, POWER ON
HTR	HEATER ELECTRIC, REACT. AIR JUMPER		

4. FOR ELECTRICAL WIRE SIZING DATA.
  - A. STANDARD. AS75001
  - B. CANADIAN. A72011
5. PROTECTIVE DEVICES HAVE BEEN PRESET AND RECORDED AT FACTORY.
6. EARTH GROUND IS TO BE INSTALLED (NOT BY C.E.C.) BEFORE ENERGIZING EQUIPMENT.
7. BEFORE EQUIPMENT START-UP, REVIEW OPERATING AND MAINTENANCE MANUAL PROVIDED WITH UNIT.
8. SEE ELECTRICAL PARTS LIST FOR COMPONENT SPECIFICATION.
9. NO = NORMALLY OPEN, OOR = OPEN ON RISE. NC = NORMALLY CLOSED, OOF = OPEN ON FALL.
10. ALL WIRING FROM J1 TO DEVICES IS TO BE #22 AWG
11. FUSIBLE LINK: PN#92329-01 (2) SPARES PROVIDED

**CONFIDENTIALITY STATEMENT**  
 THE TECHNICAL INFORMATION AND DESIGN DATA DISCLOSED HEREIN CONSTITUTE PROPRIETARY INFORMATION OF MUNTERS CARGOCAIRE AND ARE TO BE MAINTAINED IN STRICT CONFIDENCE. THIS INFORMATION IS FOR THE SOLE USE OF OUR CUSTOMERS AND END USERS OF OUR EQUIPMENT.

Job No.	STD	Date	
Customer			
Dr. By.	Y.L.	10/97	
Cl. By.	BJK	10/97	
App. By.	BJK	10/97	
Scale	NTS	Sheet	1 of 1
Size	B	Part No.	50340
Rev		Rev	11

HC-300 PART NO. 50340-01  
 DEW-300 PART NO. 50340-02

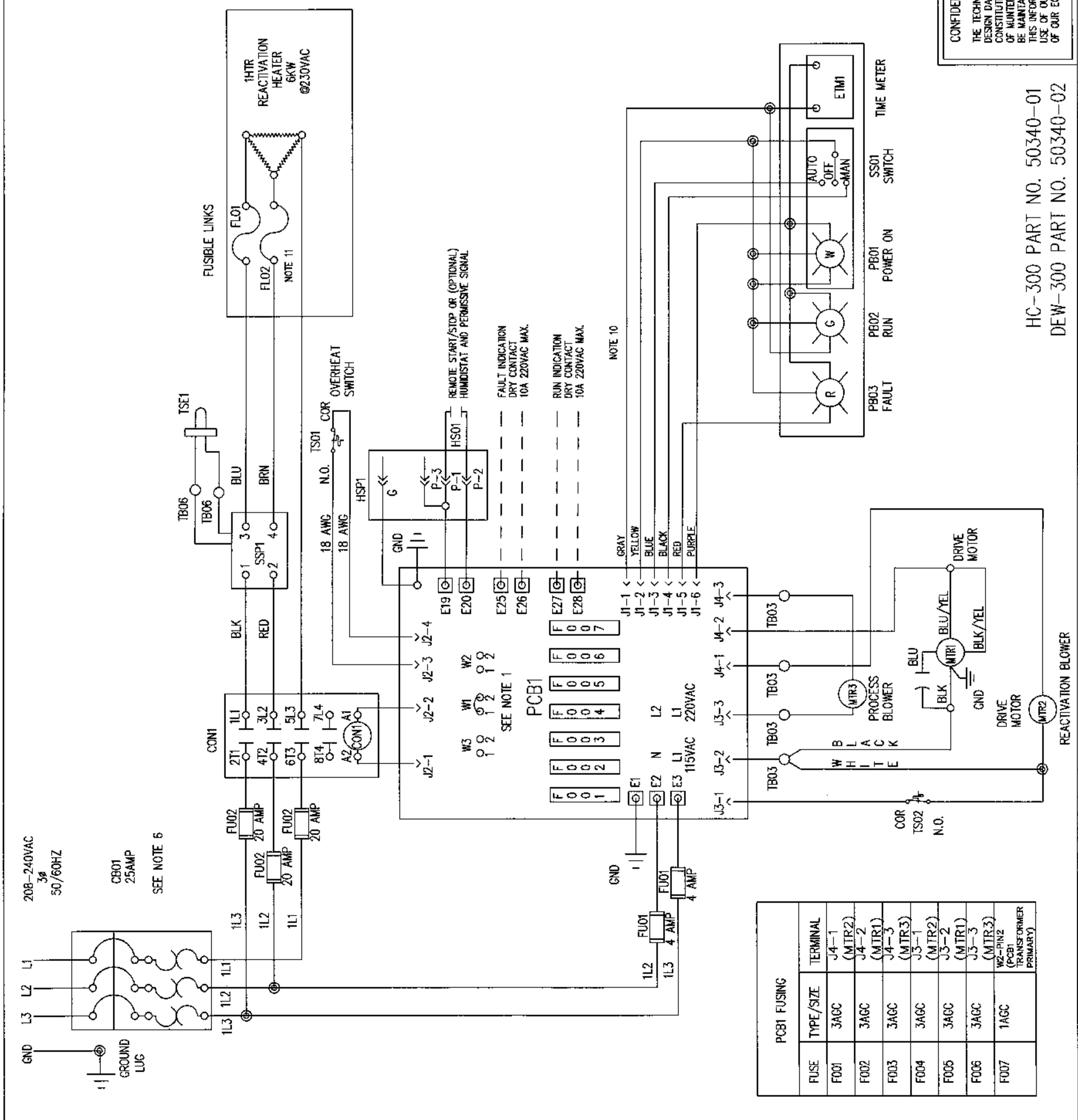

208-240VAC  
 3φ  
 50/60HZ  
 CB01  
 25AMP  
 SEE NOTE 6

NOTE 10

REMOTE START/STOP OR (OPTIONAL) HUMIDISTAT AND PERMISSIVE SIGNAL

FAULT INDICATION DRY CONTACT 10A 220VAC MAX.

RUN INDICATION DRY CONTACT 10A 220VAC MAX.

FUSIBLE LINKS

1HTR REACTIVATION HEATER 6KW @230VAC

SS01 SWITCH  
 AUTO OFF-MAN

PB01 POWER ON  
 PB02 RUN  
 PB03 FAULT

MTR3 PROCESS BLOWER  
 MTR1 DRIVE MOTOR  
 MTR2 REACTIVATION BLOWER

FUSE	TYPE/SIZE	TERMINAL
F001	3AGC	J4-1 (MTR2)
F002	3AGC	J4-2 (MTR1)
F003	3AGC	J4-3 (MTR3)
F004	3AGC	J3-1 (MTR2)
F005	3AGC	J3-2 (MTR1)
F006	3AGC	J3-3 (MTR3)
F007	1AGC	W2-PIN2 (PCB1 TRANSFORMER PRIMARY)

Rev	Description	Date	Def	Chk	App
0	SAME AS 50193R2 V/D FAN SPEED CONTROL	10/18/97	YL	BLK	BJK
1	UPDATED DRIVE MOTOR TO 300V	01/09/01	CJT	EAC	EAC
2	ADDED TB03, TB06	01/02/02	EAC	KPV	EAC
3	CHANGED FLO1 TO 4 AMPS	10/28/03	KPV	CAG	CAG
4	DELETED 50 / 60 HZ NOTE, #22 EDR 4582	6/2/04	KPV	CAG	KPV
5	NOTE 10 WAS #22 AWG	6/12/07	TLB	CAG	TLB
6	ADDED NOTE 11, PCB FUSING TABLE, FUSIBLE LINKS & NOTE 10 WAS CORRECTED	4/7/08	TLB	CAG	TLB
7	CON1 WAS A 3 POLE WITH AUX CONTACTS	7/16/08	TLB	CAG	TLB
8	ADDED FUSIBLE LINKS TO HEATER	7/24/08	TLB	CAG	TLB
9	CHANGED HSO1 CONTACT DESCRIPTION	7/1/09	N.L.	RDS	RDS
10	UPDATED NOTE 4	7/17/13	DSL	RDS	RDS
11	ADDED CONDENSATE PUMP AS OPTIONAL	03/10/14	GDD	RDS	RDS
12	REMOVED FUSE ON NEUTRAL TO COND PUMP.	04/09/14	GDD	RDS	RDS

1. PRINTED CIRCUIT BOARD POWER. FOR 115VAC JUMPER V3 1 TO 2 AND V2 1 TO 2. FOR 220VAC JUMPER V1 1 TO 2 ONLY.
2. COMPONENTS SHOWN DOTTED ARE AVAILABLE AS OPTIONS FROM C.E.C.
3. ELECTRICAL COMPONENTS - REFER TO ELECTRICAL PARTS LIST.

SYM	DESCRIPTION	SYM	DESCRIPTION
CB	CIRCUIT BREAKER, MAIN LINE	LS	ROTATION LIMIT SWITCH (OPTIONAL)
CDN	CONTACTOR, ELECTRIC HEATER	MTR	MOTOR
IPS	DIFFERENTIAL PRESSURE SWITCH	PB	PUSHBUTTON
E	TERMINAL, SPARE TYPE	PCB	PRINTED CIRCUIT BOARD
ETH	ELAPSED TIME METER	R	RED. INDICATOR LIGHT, FAULT
F	FUSE (PCB)	SSP	SOLID STATE POWER CONTROLLER
FL	FUSIBLE LINK	TB	TERMINAL BLOCK
FU	FUSE	TS	THERMISTAT
G	GREEN, INDICATOR LIGHT, RUNNING	TSE	THERMISTER
HS	HUMIDISTAT	SS	SELECTOR SWITCH
HSP	HUMIDISTAT PLUG	V	WHITE, INDICATOR LIGHT, POWER ON
HTR	HEATER ELECTRIC, REACT.		
J	JUMPER		

4. FOR ELECTRICAL WIRE SIZING DATA.
  - A. STANDARD. AS75001
  - B. CANADIAN. A72011
5. PROTECTIVE DEVICES HAVE BEEN PRESET AND RECORDED AT FACTORY.
6. EARTH GROUND IS TO BE INSTALLED (NOT BY C.E.C.) BEFORE ENERGIZING EQUIPMENT.
7. BEFORE EQUIPMENT START-UP, REVIEW OPERATING AND MAINTENANCE MANUAL PROVIDED WITH UNIT.
8. SEE ELECTRICAL PARTS LIST FOR COMPONENT SPECIFICATION.
9. NO = NORMALLY OPEN, ODR = OPEN ON RISE. NC = NORMALLY CLOSED, ODF = OPEN ON FALL.
10. ALL WIRING FROM J1 TO DEVICES IS TO BE #22 AWG
11. FUSIBLE LINK: PN#92329-01 (2) SPARES PROVIDED

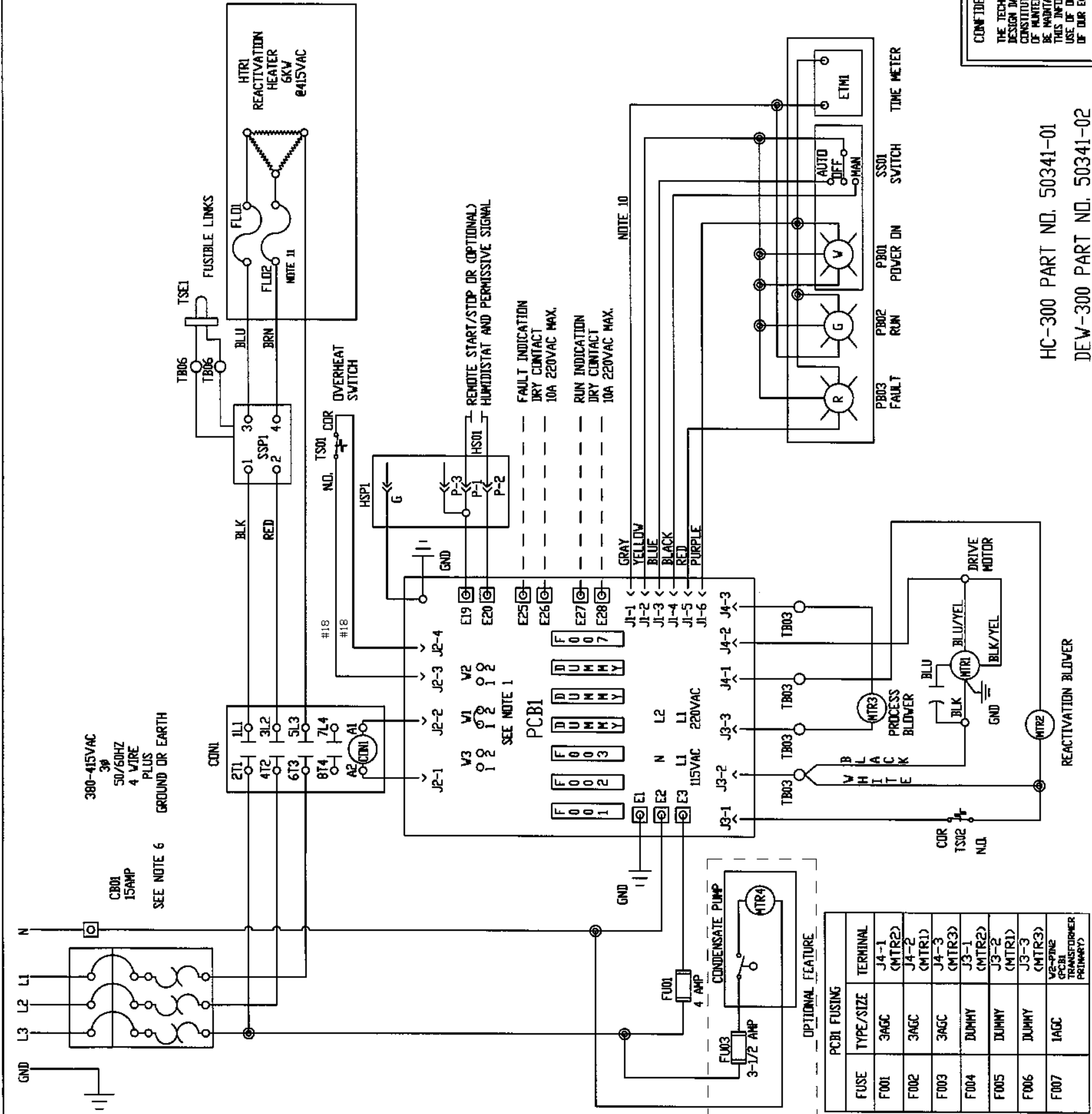

**CONFIDENTIALITY STATEMENT**  
 THE TECHNICAL INFORMATION AND DESIGN DATA DISCLOSED HEREIN CONSTITUTE PROPRIETARY INFORMATION OF MUNTERS CARGOCAIRE AND ARE TO BE MAINTAINED IN STRICT CONFIDENCE. THIS INFORMATION IS FOR THE SOLE USE OF OUR CUSTOMERS AND END USERS OF OUR EQUIPMENT.

Job No.	STD	Date	
Customer	-----		
By	Y.L.	10/97	
Chk	BJK	10/97	
App'd	BJK	10/97	
Scale	NTS	Sheet	1 of 1
Size	B	Part No.	50341
Rev			12

Munters Cargoaire  
 79 Monroe St. Amesbury, Ma 01913  
 TEL 978-388-4600 FAX 978-388-4632  
 WIRING DIAGRAM  
 DEW/HC-300  
 380-415VAC 3Ø 50/60HZ

HC-300 PART NO. 50341-01  
 DEW-300 PART NO. 50341-02

Rev	Description	Date	Drft	App
1	SAME AS 50194R4 WITHOUT FAN CONTROL.	10/98	YL	BK
2	FU02 WAS 3-1/2 AMP & FU01 WAS 10 AMP - DELETED DIP SWITCH SETTING FOR FAN SPEED CONTROLLER.	12/97	BK	BK
3	UPDATED DRIVE MOTOR TO BODINE.	01/09/01	ICJT	EAC
4	ADDED TB03, TB06	01/02/02	EAC	KPV/EAC
5	FUSIBLE LINK SHOWN ON HEATER ASSEMBLY	10/31/02	WEH	KY
6	CHANGED FU01 FROM 5A TO 10A	4/20/03	GJM	GR
7	CHANGED FU01 FROM 10A TO 6A	7/30/03	GJM	GR
8	CHANGED FU01 FROM 6A TO 4A	10/28/03	KPV	CAG
9	CHANGED TB03 TO TB06 ON TSEL.	02/24/04	CAG	KPW/CAG
10	CHANGED FU01 FROM 4A TO 6A	02/26/04	CAG	KPW/CAG
11	ADDED SSS01/H0A SWITCH (OPTIONAL CONTACTS) AND NOTE 11	04/15/05	RSC	CAG
12	CHANGED COLOR OF POWER INDICATOR LIGHT FROM AMBER TO WHITE.	04/15/05	RSC	CAG
13	FU02 WAS 28A IS NOW 35A	08/24/05	RSC	EJL
14	NOTE 10 WAS #22 AWG	6/12/07	TLB	CAG
15	ADDED PCB FUSING TABLE CORRECTED W1,2,3 JUMPERS, CORRECTED NOTE 10	4/1/08	TLB	CAG
16	CHANGED TERMINAL #'S ON CON1 - DO NOT USE #'S 14 & 13	5/14/08	TLB	CAG
17	CON1 WAS A 3 POLE WITH AUX CONTACTS	7/16/08	TLB	CAG
18	MOVED JUMPER TO W1 ON PCB1	10/22/08	TLB	CAG
19	INPUT POWER WAS 3787	3/24/09	TLB	RS
20	CHANGED HS01 CONTACT DESCRIPTION ON HSP1	7/1/09	MJL	RDS
21	UPDATED NOTE 4	7/17/13	DSL	RDS

- PRINTED CIRCUIT BOARD POWER.  
FOR 115VAC JUMPER W3 1 TO 2 AND W2 1 TO 2.  
FOR 220VAC JUMPER W1 1 TO 2 ONLY.
- COMPONENTS SHOWN DOTTED ARE AVAILABLE AS OPTIONS FROM C.E.C.
- ELECTRICAL COMPONENTS - REFER TO ELECTRICAL PARTS LIST.

SYM	DESCRIPTION	SYM	DESCRIPTION
CB	CIRCUIT BREAKER, MAIN LINE	LS	ROTATION LIMIT SWITCH (OPTIONAL)
CON	CONTACTOR, ELECTRIC HEATER	MTR	MOTOR
DPS	DIFFERENTIAL PRESSURE SWITCH	PB	PUSHBUTTON
E	TERMINAL, SPARE TYPE	PCB	PRINTED CIRCUIT BOARD
ETM	ELAPSED TIME METER	R	RED, INDICATOR LIGHT, FAULT
F	FUSE (PCB)	SS	SELECTOR SWITCH
FL	FUSIBLE LINK	SSP	SOLID STATE POWER CONTROLLER
FU	FUSE	T	TRANSFORMER
G	GREEN, INDICATOR LIGHT, RUNNING	TB	TERMINAL BLOCK
HS	HUMIDISTAT	TS	THERMOSTAT
HSP	HUMIDISTAT PLUG	TSE	THERMISTER
HTR	HEATER ELECTRIC, REACT. AIR	W	WHITE, INDICATOR LIGHT, POWER ON
J	JUMPER		

- FOR ELECTRICAL WIRE SIZING DATA.  
A. STANDARD, AS75001  
B. CANADIAN, A72011
- PROTECTIVE DEVICES HAVE BEEN PRESET AND RECORDED AT FACTORY.
- EARTH GROUND IS TO BE INSTALLED (NOT BY C.E.C.) BEFORE ENERGIZING EQUIPMENT.
- BEFORE EQUIPMENT START-UP, REVIEW OPERATING AND MAINTENANCE MANUAL PROVIDED WITH UNIT.
- SEE ELECTRICAL PARTS LIST FOR COMPONENT SPECIFICATION.
- NO = NORMALLY OPEN, NDR = OPEN ON RISE
- NC = NORMALLY CLOSED, DOF = OPEN ON FALL
- ALL WIRING FROM J1 TO DEVICES IS TO BE #22 AWG
- FUSIBLE LINK P/N 92329-01 (2) SPARES PROVIDED.

**CONFIDENTIALITY STATEMENT**  
THE TECHNICAL INFORMATION AND DESIGN DATA DISCLOSED HEREIN CONSTITUTE PROPRIETARY INFORMATION OF MUNTERS CARBOCOPRE AND ARE TO BE MAINTAINED IN STRICT CONFIDENCE. THIS INFORMATION IS FOR THE SOLE USE OF OUR CUSTOMERS AND END USERS OF OUR EQUIPMENT.

Job No: STD  
Customer: Munters CarboCopre  
Date: 10/97  
Date: 10/97  
Date: 10/97

WIRING DIAGRAM  
DEV/HC-300  
460VAC 3Ø 50/60HZ

NTS 1 of 1 B 50342  
REV 21

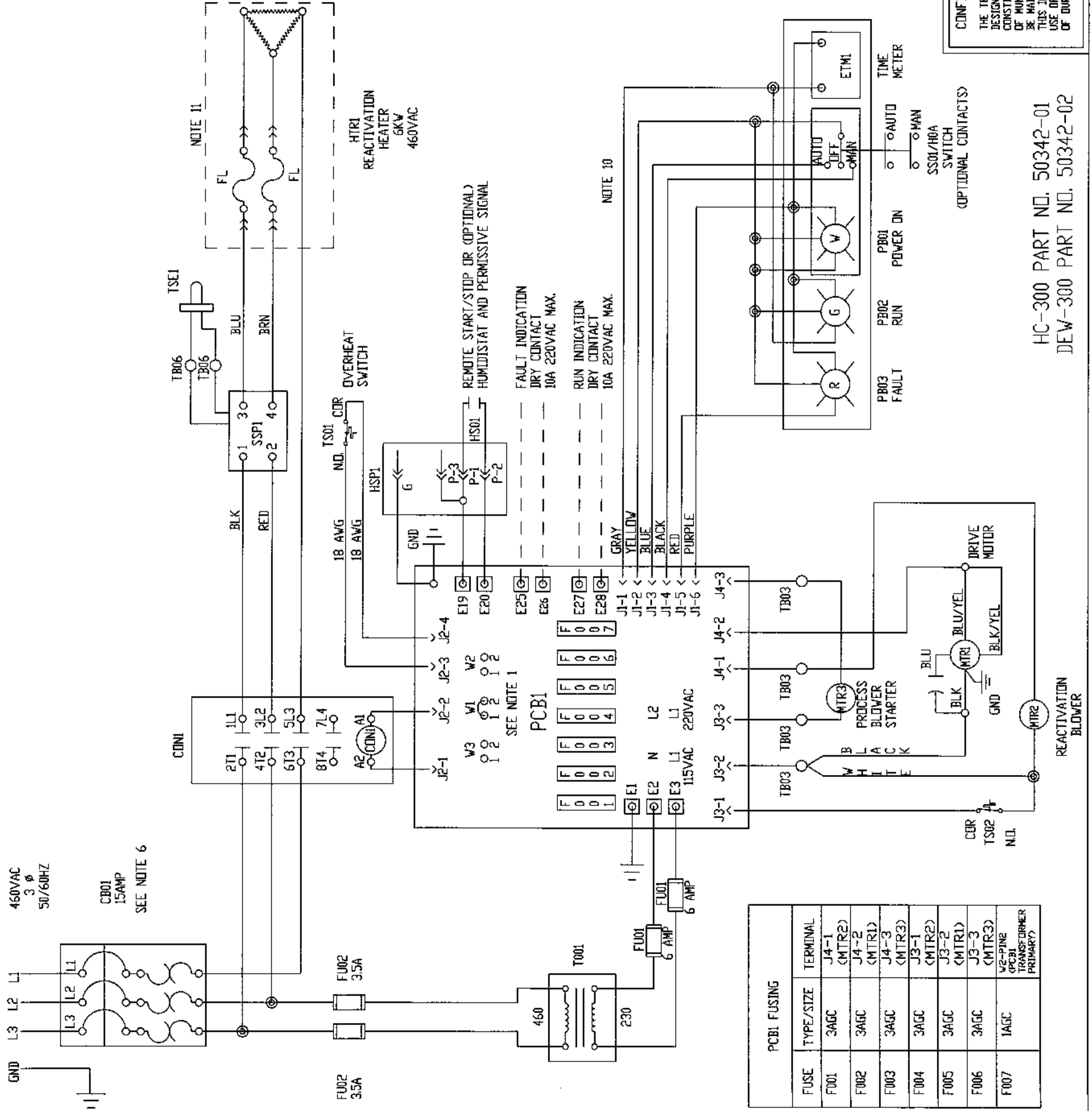

HC-300 PART NO. 50342-01  
DEW-300 PART NO. 50342-02



## HC 300 DEHUMIDIFIER REPLACING FUSIBLE LINKS

### **1. DANGER: HIGH VOLTAGE: TURN POWER OFF BEFORE SERVICING!!!**

### **2. LOCATE REACTIVATION INLET BOX**

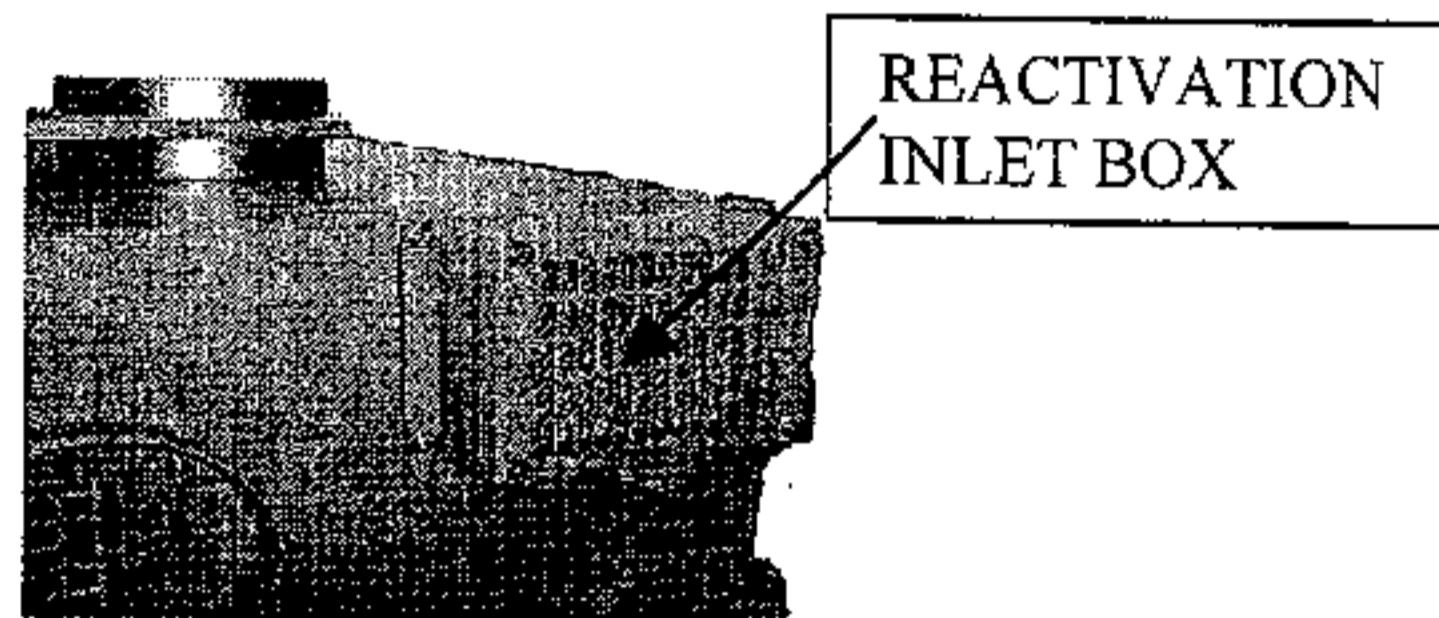

### **3. REMOVE (3) 1/4-20 BOLTS FROM THE INLET GRILL**

### **4. LOOSEN THE 4<sup>TH</sup> SCREW & ROTATE 90° TO EXPOSE THE INLET METAL MESH FILTER AND RETIGHTEN THE 4<sup>TH</sup> SCREW TO HOLD THE GRILL IN PLACE.**

### **5. REMOVE THE BOTTOM FILTER PANEL BY HAND LOOSENING THE (2) CAPTIVE SCREWS ON THE BOTTOM FILTER PANEL.** ***CAUTION: METAL MESH FILTER MAY DROP OUT AS THE BOTTOM PANEL IS REMOVED.***

### **6. REMOVE METAL MESH FILTER.**

### **7. THE OPENED REACTIVATION INLET SHOULD LOOK LIKE THIS.**

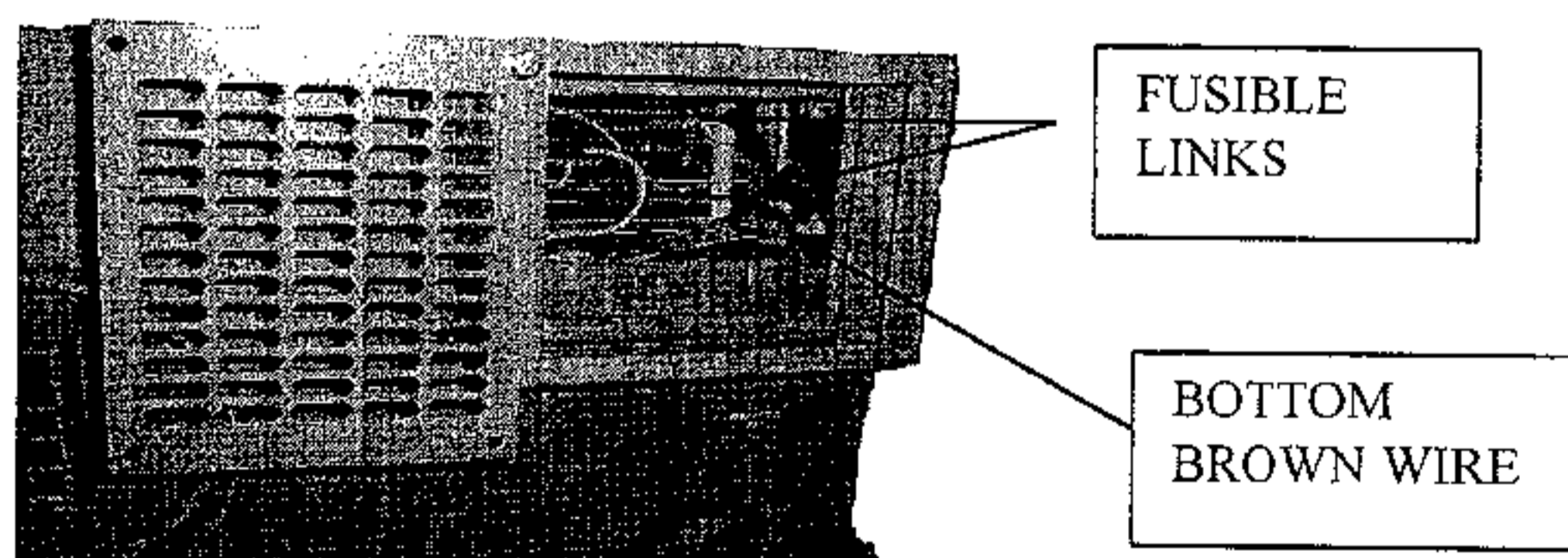

### **8. REMOVE THE BOTTOM BROWN WIRE (FEMALE SPADE) FROM THE MALE SPADE ON THE BOTTOM OF THE HEATING ELEMENT. CAUTION: DO ONLY ONE WIRE AT A TIME.**

### **9. REMOVE INSULATED MALE SPADE TERMINAL FROM THE INSULATED FEMALE SPADE ATTACHED TO THE BROWN WIRE.**

**10. ASSEMBLE NEW FUSE SUB ASSEMBLY. CRIMP THE NON INSULATED FEMALE TERMINALS TO BOTH SIDES OF THE FUSE.**

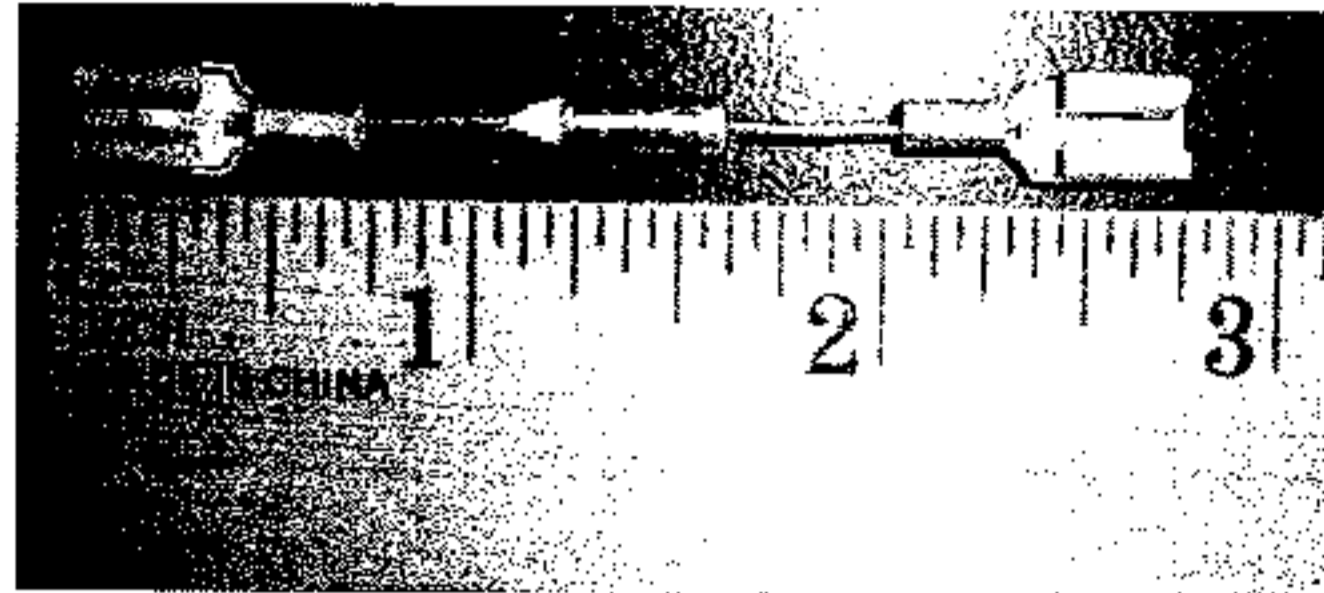

**11. REMOVE FUSE ASSEMBLY FROM HEATER BY PULLING STRAIGHT OUT ON THE UNINSULATED FEMALE TERMINALS.**

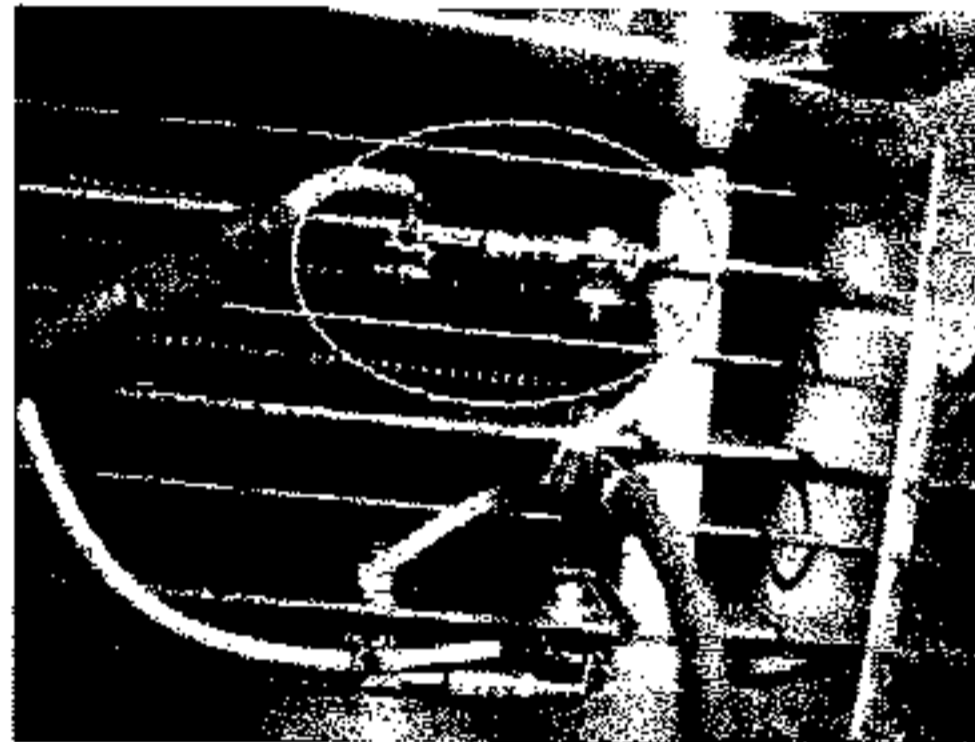

**12. REPLACE FUSABLE LINK WITH NEW FUSE SUB ASSEMBLY BY REINSTALLING FEMALE TERMINALS TO SYSTEM TABS.**

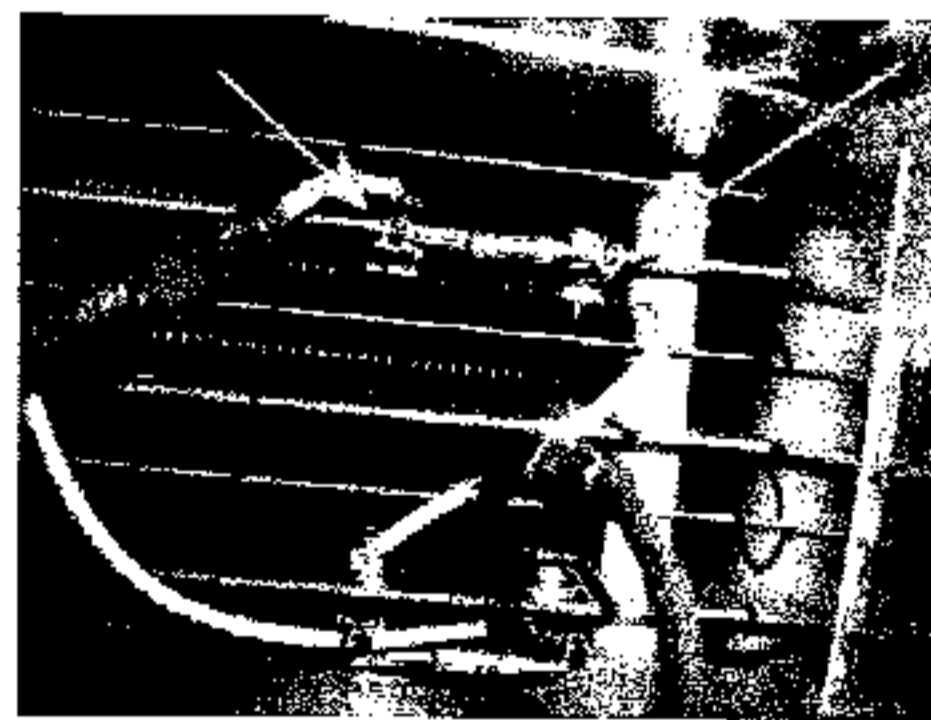

**13. REPEAT STEPS 8 THROUGH 12 FOR THE SECOND REPLACEABLE FUSE.**

**14. BOTH FUSE ASSEMBLIES MUST BE INSIDE THE INNER REACTIVATION CHAMBER BEFORE REINSTALLING THE METAL MESH FILTER.**

**15. REASSEMBLY: REVERSE STEPS 1 THRU 6.**

# HC-150 and HC-300 Humidistat Field Connections

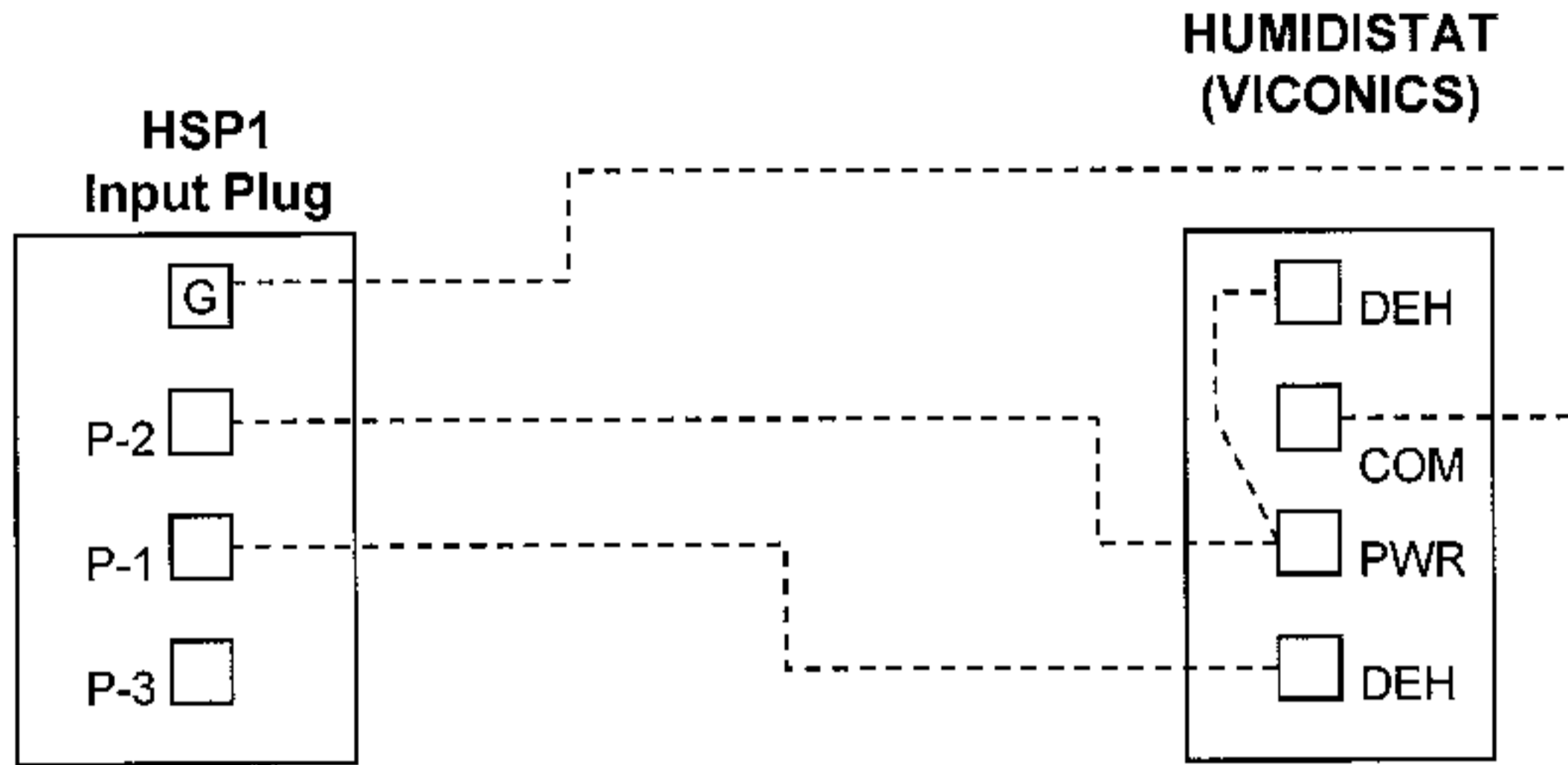

All Dashed Wiring by others

HC-150 / 300



HSP1 Input Plug

Regin Humidistat p/n 90485-xx

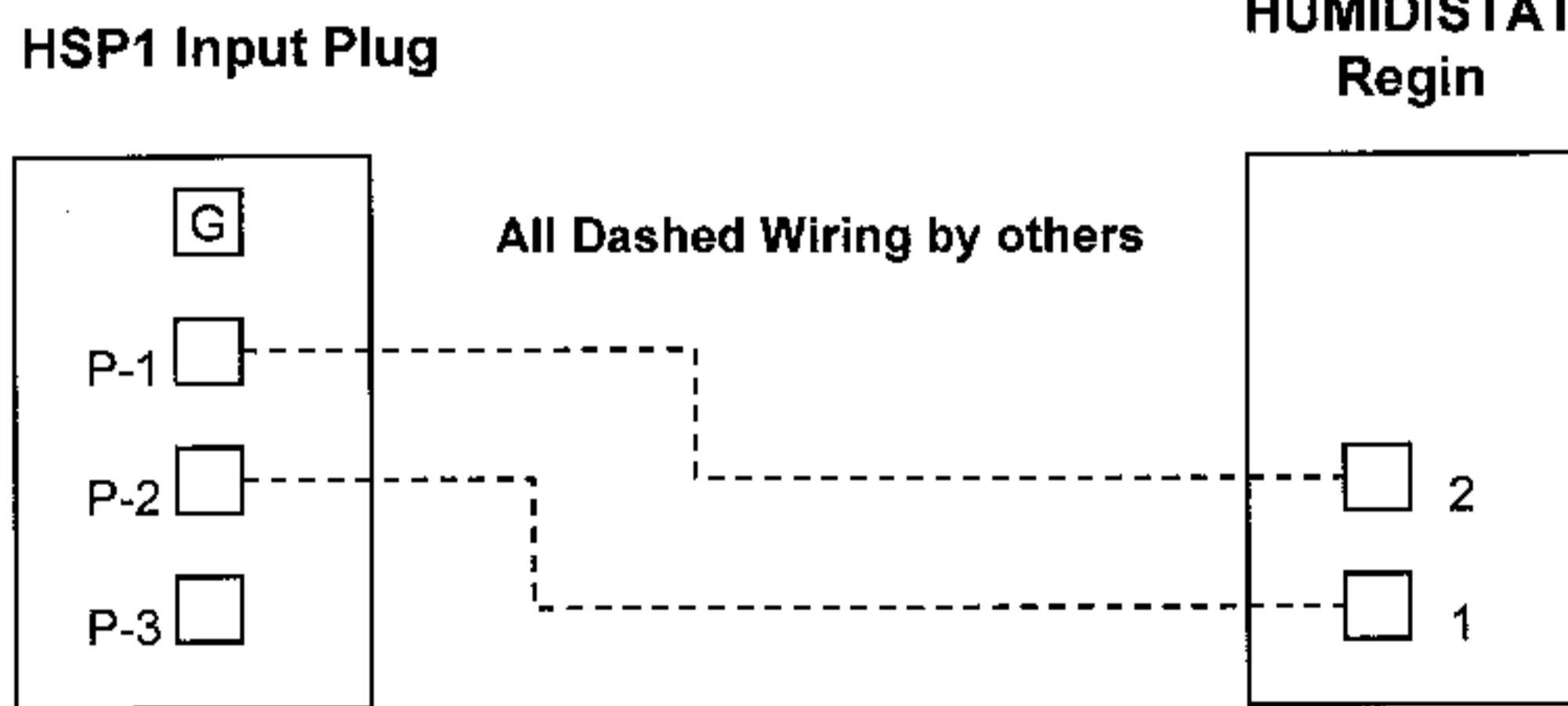
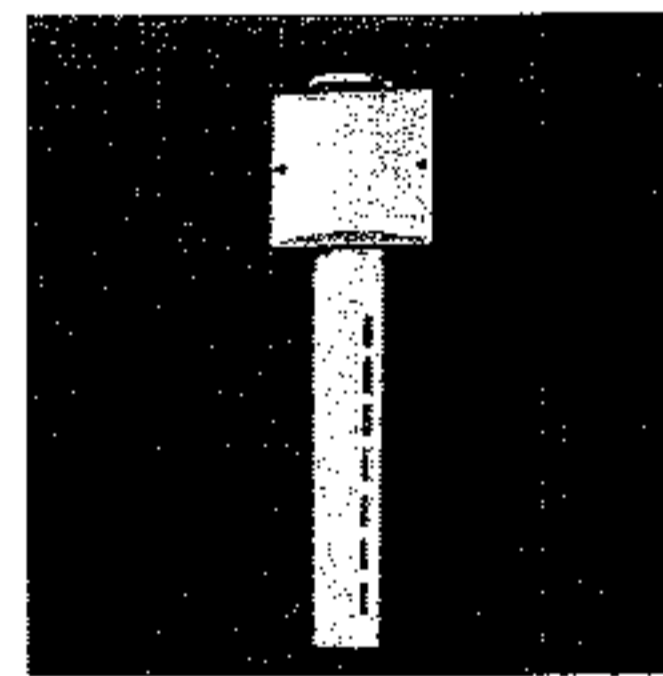

All Dashed Wiring by others

## H200 Direct Connect to HC-150/300 Circuit Board

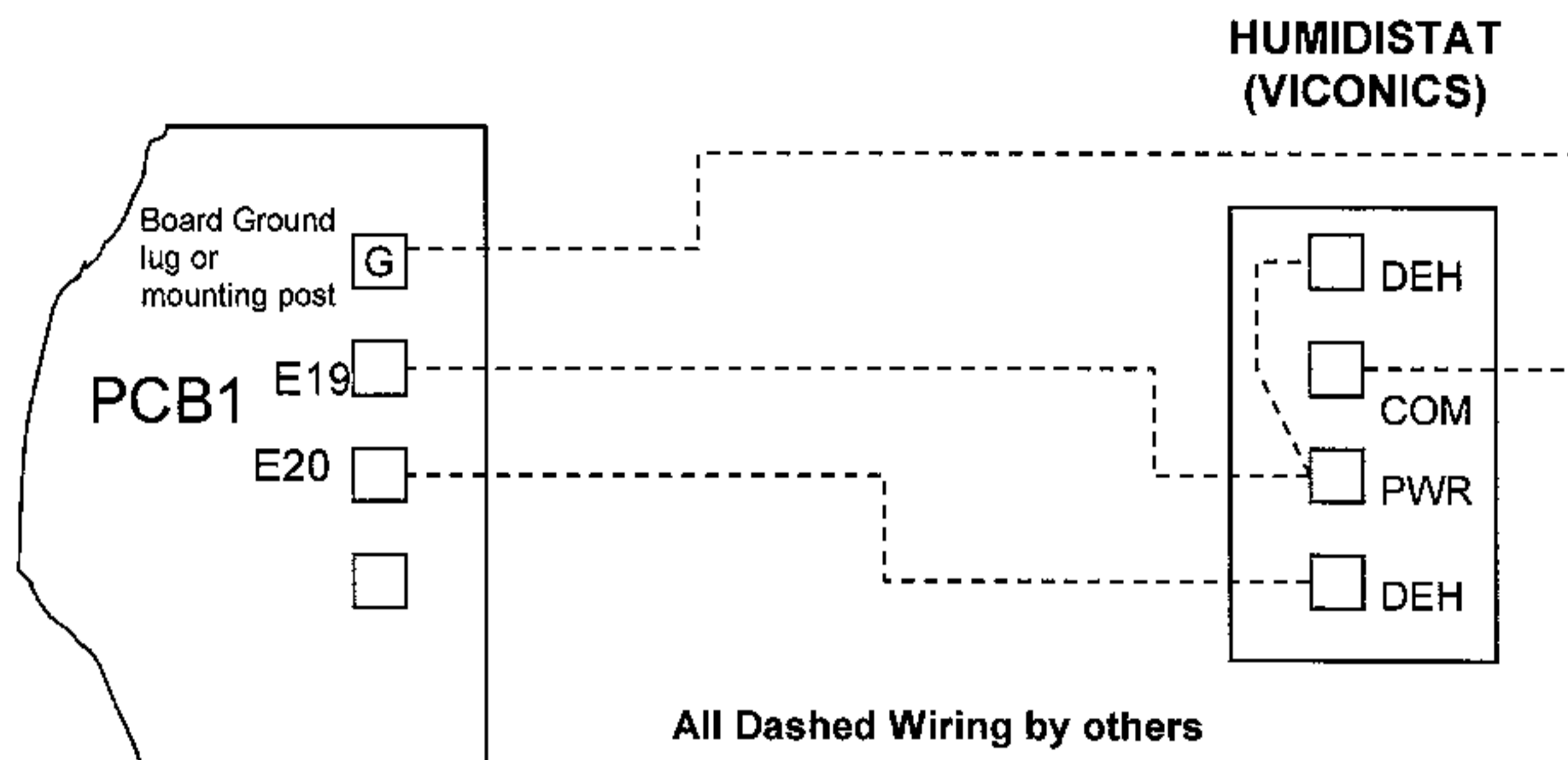

**Main Unit Circuit Board**

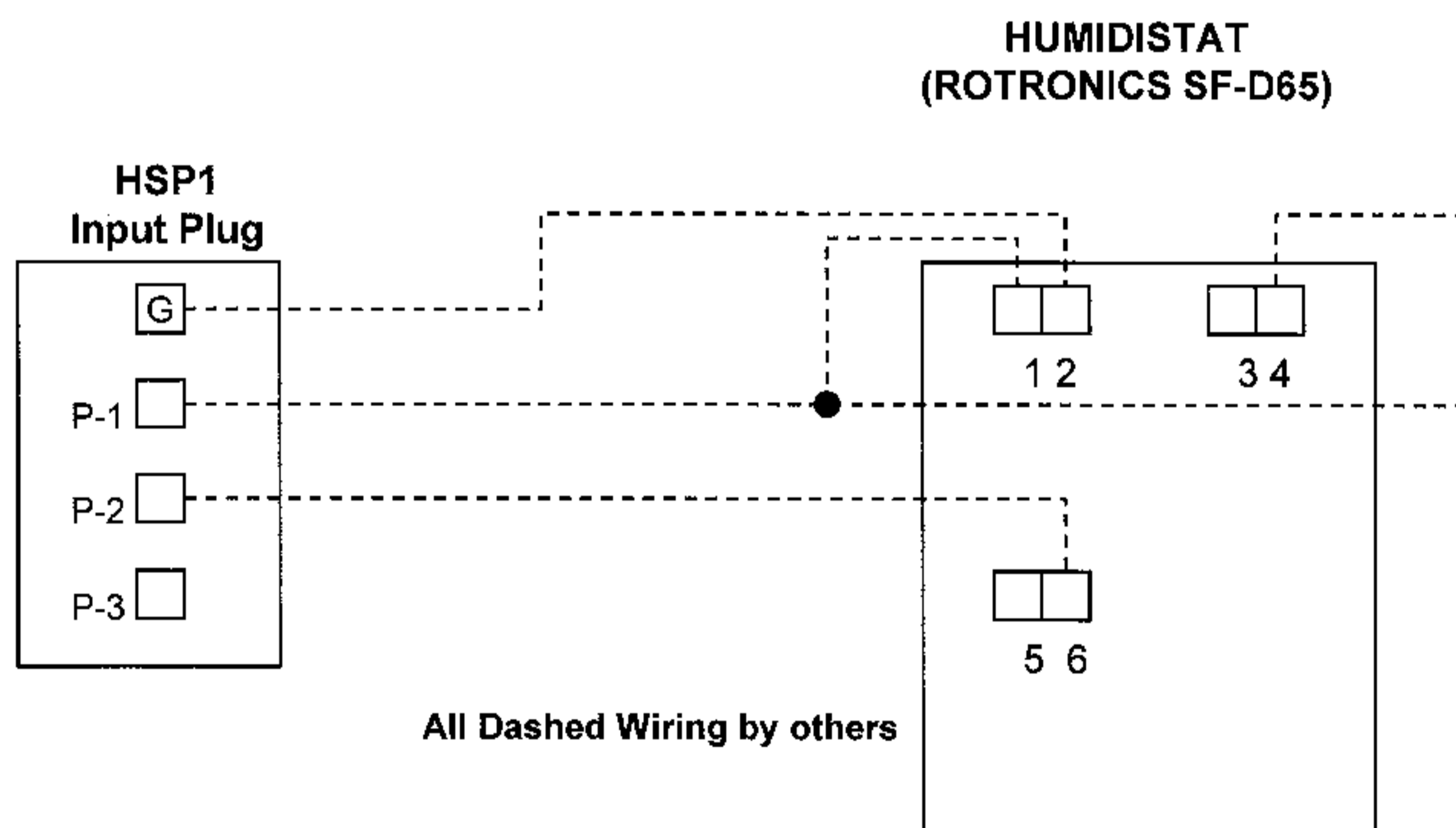

## BLASTGATE INSTALLATION INSTRUCTIONS FOR

### HC-150 & DEW-150

USING A 5" BLASTGATE DRILL (3) 3/16 DIAMETER HOLES EQUALLY SPACED ON CONNECTION RING OF THE BLASTGATE ON THE SIDE OPPOSITE THE DAMPER BLADE LOCKING SCREW.

APPLY THE ADHESIVE BACKED GASKET SUPPLIED, TO THE INSIDE DIAMETER OF THE BLASTGATE. INSTALL THE BLASTGATE TO THE PROCESS OUTLET CONNECTION RING. WHEN INSTALLING THE BLASTGATE BE CERTAIN THAT IT IS INSTALLED IN SUCH A MANNER TO ALLOW THE BLASTGATE TO OPEN COMPLETELY ALLOWING FULL MODULATION. ALSO CHECK TO MAKE CERTAIN THERE IS NO INTERFERENCE FROM ANY DUCTWORK, WALLS, FILTER BOXES, ETC. USING THE BLASTGATE AS A GUIDE DRILL (3) 5/32 DIAMETER HOLES THROUGH THE CONNECTION RING OF THE DEHUMIDIFIER. INSTALL (3) 10-32 SELF TAPPING SCREWS THROUGH THE BLASTGATE. REPEAT PROCEDURE FOR THE 4" BLASTGATE FOR REACTIVATION OUTLET.

### HC-300 & DEW-300

USING 8" BLASTGATE DRILL (3) 3/16 DIAMETER HOLES EQUALLY SPACED ON CONNECTION RING OF THE BLASTGATE ON THE SIDE OPPOSITE THE DAMPER BLADE LOCKING SCREW.

INSTALL THE BLASTGATE TO THE PROCESS OUTLET CONNECTION RING. WHEN INSTALLING THE BLASTGATE BE CERTAIN THAT IT IS INSTALLED IN SUCH A MANNER TO ALLOW THE BLASTGATE TO OPEN COMPLETELY ALLOWING FULL MODULATION. ALSO CHECK TO MAKE CERTAIN THERE IS NO INTERFERENCE FROM ANY DUCTWORK, WALLS, FILTER BOXES, ETC. USING BLASTGATE AS GUIDE DRILL (3) 5/32 DIAMETER HOLES THROUGH THE CONNECTION RING OF THE DEHUMIDIFIER. INSTALL (3) SELF TAPPING SCREWS THROUGH BLASTGATE.

### BLASTGATE INSTALLATION INSTRUCTION FOR CONNECTION TO DUCTWORK HC-150, DEW-150, HC-300 & DEW-300

USE FLEXIBLE CONNECTION AT THE DEHUMIDIFIER. LOCATE THE DAMPER IN A STRAIGHT RUN OF THE DUCTWORK OF PROCESS OUTLET IN AN EASILY ACCESSIBLE AREA TO FACILITATE ADJUSTMENTS. INSTALL BLASTGATE INTO DUCTWORK. DRILL 5/32 DIAMETER HOLES THROUGH DUCTWORK AND CONNECTION RING OF BLASTGATE. INSTALL 10-32 SELF TAPPING SCREWS. REPEAT PROCEDURE FOR HC-150 OR DEW-150 FOR REACTIVATION OUTLETS.

REVISION 1 - ADDED COMMENT ON BLASTGATE MOUNTING 10/27/92 EJL *EJL*

<b>Munters Cargocaire</b> Amesbury, Massachusetts 01913	DFT PAH	DATE 6/92	DWG NO.	
	CHK EJL	6/92	<b>A27110</b>	
BLASTGATE INSTALLATION INSTRUCTIONS	APP EJL	6/92		
	CODE IDENT. <b>#82974</b>	1 OF 1	REV 1	

21239

## Recommended Spare Parts List

HC-300

MODEL: HC-300

DESCRIPTION	P/N	QTY REQ
<b>WHEELS (REPLACEMENT KITS)</b>		
SIGEL (Titanium Enhanced Silica Gel)	30146-12	(1)
<b>SEALS</b>		
SEAL KIT, UPPER & LOWER	43552-02	(1)
<b>MOTORS</b>		
DRIVE MOTOR (S/N J92>)	92483-01 220V	(1)
<b>BELTS</b>		
DRIVE BELT	91626-03	(1)
<b>FILTERS</b>		
PROCESS IN	95007-29	(1)
REACT IN	95007-40	(1)
<b>ROLLERS</b>		
DESICCANT SUPPORT	15985	(2)
<b>HEATERS</b>		
460V 3PH	91761-09	(1)
208-230V 3PH	91761-01	(1)
208V-230V 1PH	91761-02	(1)

REV	DESCRIPTION	DFT	DATE	APP
-03	CHANGED 30146-11 TO 30146-12 PER ECR 12-00129MA	TJM	05/15/13	TJM
-02	DRIVE MOTOR WAS 92054-02, HEATERS WERE 91719 SERIES.	SAH	02/03/04	SAH
-01	CHANGED REACT. FILTER P/N FROM -30 TO -40	EJL	12/01/98	EJL
REVISIONS				

<b>Munters Corporation</b> 79 Monroe Street Amesbury, MA 01913	DFT	GR	DATE	2/97	REF SPEC #	DWG NO.	21239
	CHK	GR	DATE	2/97	CUST NAME: STANDARD		
	APP	SB	DATE	2/97	PAGE 1 OF 1	CODE IDENT # 82974	REV 3

