



LINCOLN MK. I.

ELECTRICAL SERVICES

THEORETICAL DIAGRAMS

ROUTING CHARTS

AP 2847 A & B

Vol. 1.

- 1 FUSELAGE NOSE
- 2 FIRST LANDING GEAR SECTION
- 3 CENTRE SECTION
- 4 REAR CENTRE SECTION
- 5 FUSELAGE REAR SECTION
- 6 NOSE GUN TURRET
- 7 DORSAL GUN TURRET (See Section 7)
- 8 TAIL GUN TURRET
- 9 DOWN DOORS
- 10 ENGINES
- 11 ENGINE SURFACES
- 12 UNDERCARRIAGE BEAMS
- 13 MAIN WHEEL DOORS AND VALANCE
- 14 MAIN WHEEL UNIT
- 15 FLAPS - INBOARD
- 16 TRAILING EDGE CENTRE SECTION
- 17 ENGINE SURFACE OUTBOARD
- 18 TRAILING EDGE INTERMEDIATE PLANE
- 19 FLAPS - OUTBOARD
- 20 INTERMEDIATE PLANE
- 21 ALLENS
- 22 OUTER PLANE
- 23 ELEVATORS
- 24 RUDDERS
- 25 FINN
- 26 TAIL PLANE
- 27 TAIL WHEEL

SEE SECTION 12

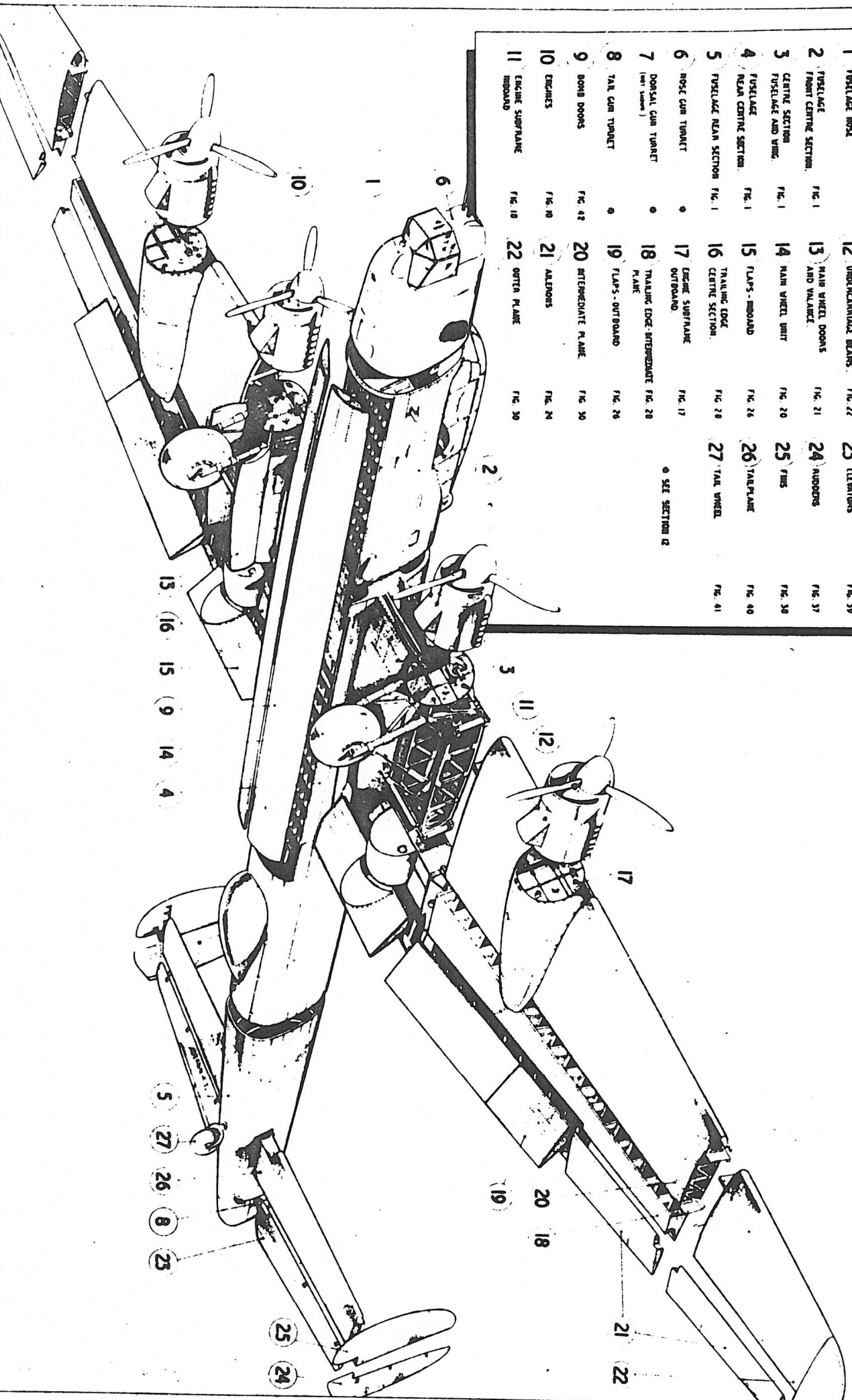

SECTIONS OF AIRCRAFT

FIG. 1

FIG. 1

I N D E X

Pl. No. Section 6, Chapter 1	Pl. No. Section 6 Chapter 1.
1A. Location of Electrical Equipment.	18. Engine Printing
1B. Location diagram - bomb fuzing and release.	19. Bomb Fuzing Rel. Supply & Flap Indicator Heated Pressure.
2. Theoretical diagrams.	20. Long Range Tanks - Fuel Pumps - XL & Long Range Fuel Contents
2A. "	21. Radial Feeder distribution.
2B. "	22. Scanner Unit Heater, Heated Clothing Socket, Trans. Type F Call Lights.
2C. "	23. General Lighting and Beam Approach Supply
2D. "	24. Bomb fuzing and release
2E. "	25. Flare chute Mk. V
3. Generator Controls and Alternator Supply.	26. All Turret supplies and internal distribution.
4. Engine Starter, Booster and Ignite.	27. Auto. Bomb Sight & Auto. Controls & I.T. & H.T. Supply.
5. Propeller Feathering.	28. Camera Supply & Heating.
6. Fire Ext. - fire bottles.	29. D.R. Compress
7. Fire Ext. - Warning lights.	30. G.P.I. and A.M.V.
8. Oil & Radiator Temp. Thermometer.	31. W/T Supplies and Demolition
9. Fuel Flowmeter & Oil Pressure Indicators.	32. Motor Generator for Scanning Unit
10. Air Intake, Slow Running Cut-off Control & Air cleaner Cont.	33. Rear Turret Supply Boulton Paul type D & Internal distrib.
11. Supercharger Control & Radiator Flaps.	34. Section 2
12. Fuel Press. Warn. Lights & Oil Dilution System.	4. Stowing Q type Dinghy {1}
13. Landing Lamp & Engine Speed Indicators.	5. " " " {2}
14. Fuel Pumps.	6. " " " {3}
15. Fuel Contents Gauges.	Vol. 1 Section 4
16. Undercarriage Indicators.	Vol. 1 Section 5
17. Navigation, Recog. & Ident. Lamps.	1. Sections of Aircraft
	5 Weatherproofing
	9 Firewall Details
	17 Outboard Engine Sub-Frame
	22 Undercarriage Beams
	23 " "
	Vol. 1 Section 7
	1 Section 7
	4 Canopy
	5 Main Plane Centre. Section 7
	7 Floors

GROUND EQUIPMENT

BOMB - ARMED'S PANEL STANDARD

COM REF

J. B. A.

COM REF

PILOT'S EQUIPMENT

BOMB FUZING AND RELEASE - T

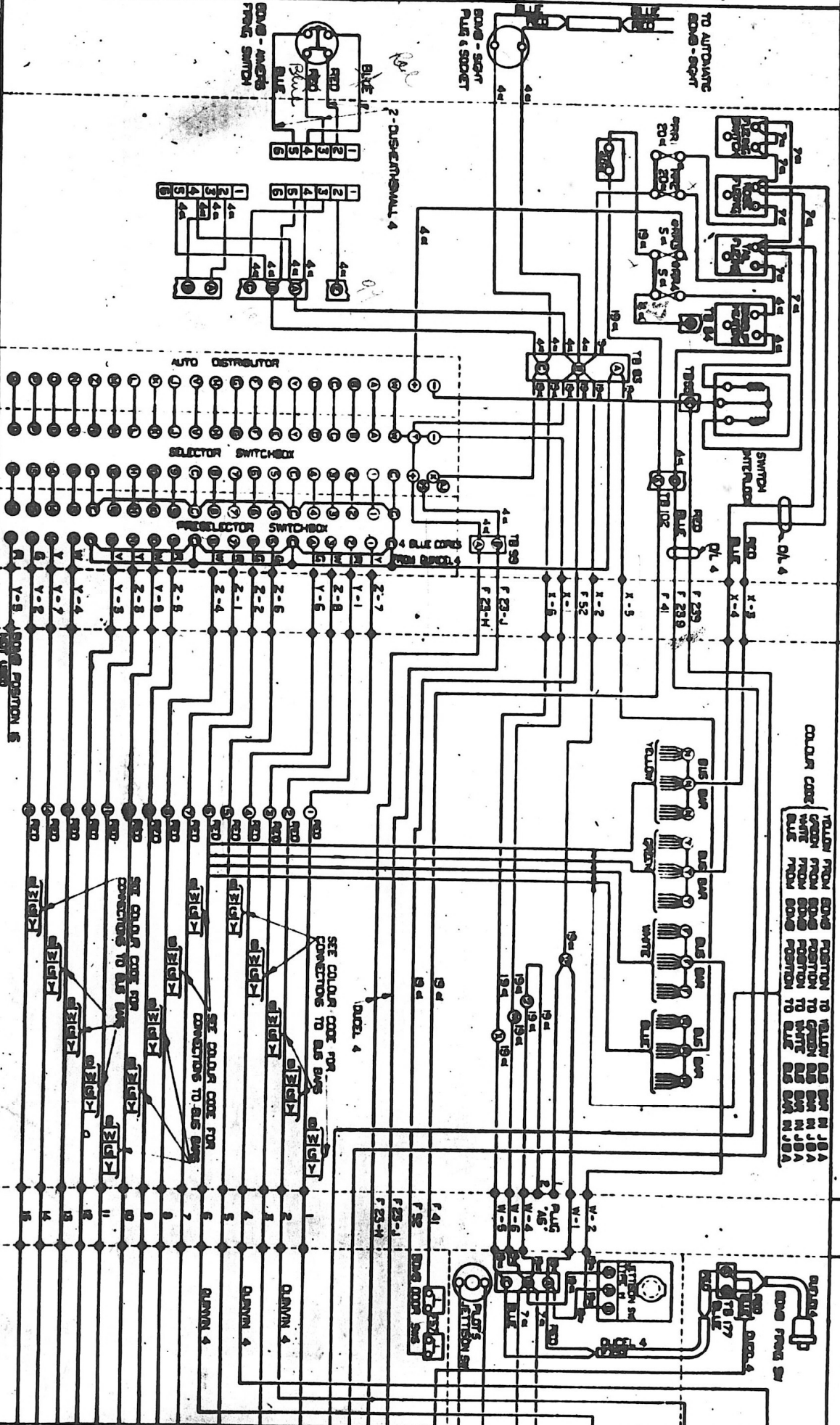

FIG 25

V2565

ROUTING CHART





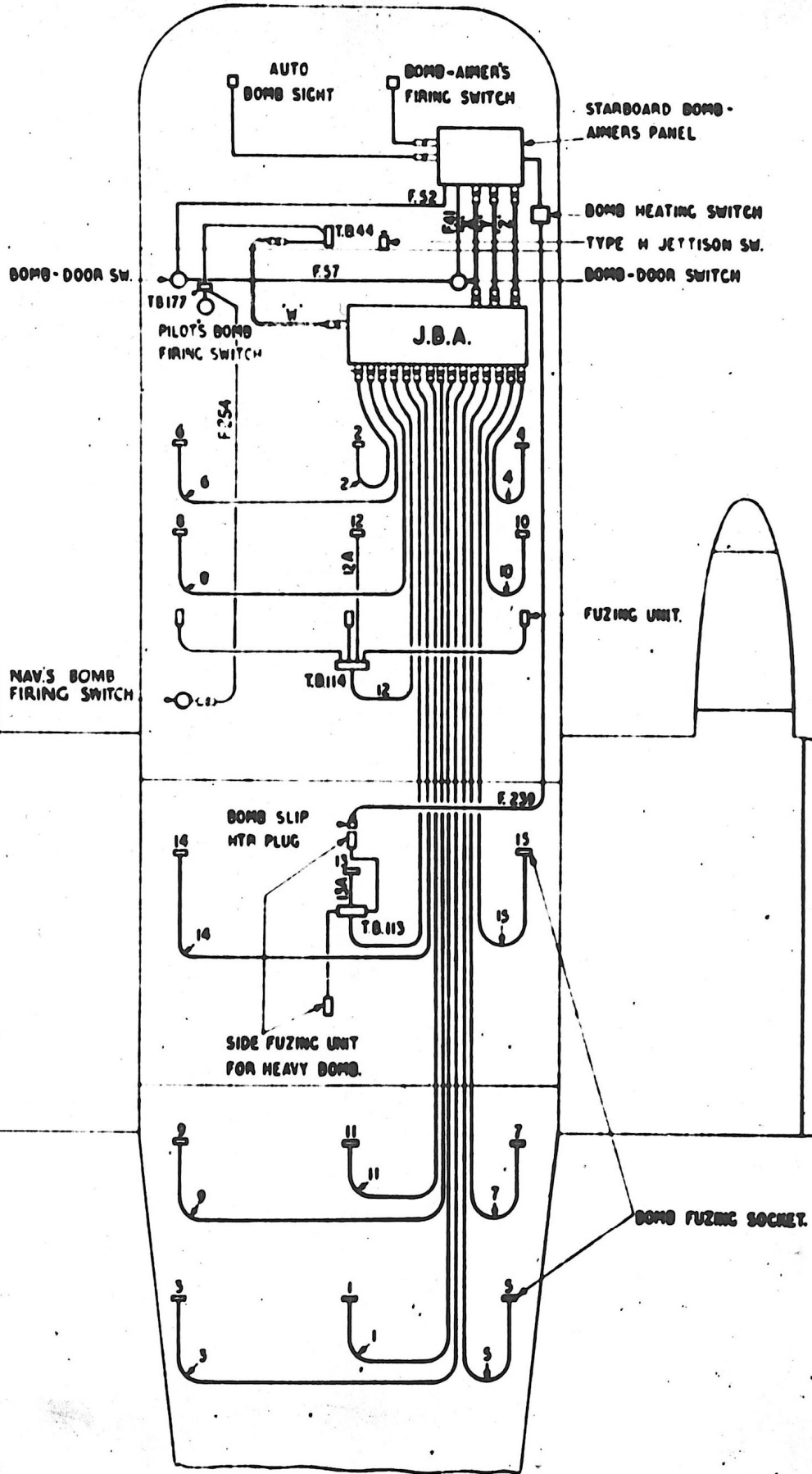

*Handwritten signature or initials, possibly 'W. J. Roberts'.*

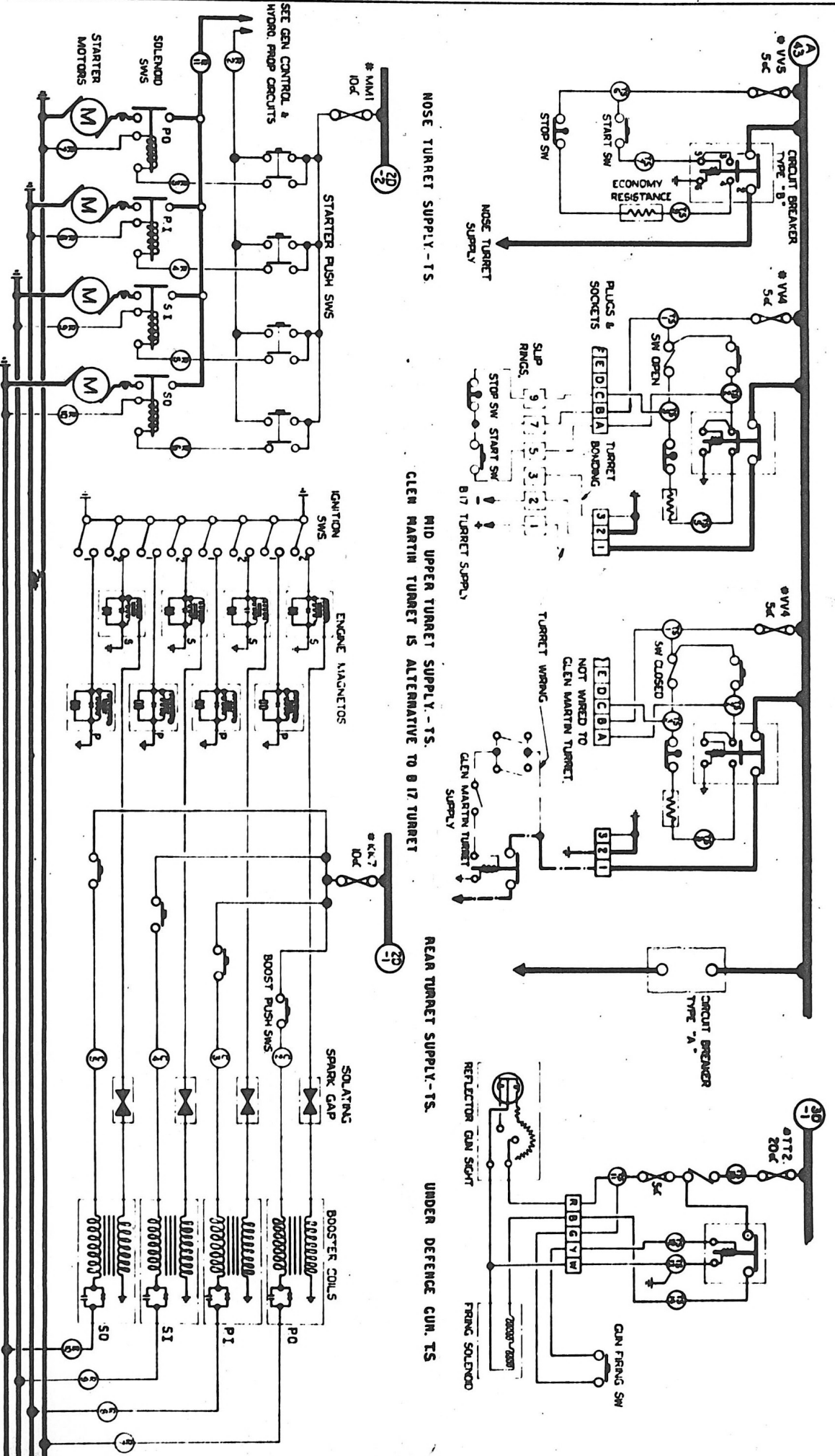

# ELECTRICAL SERVICES

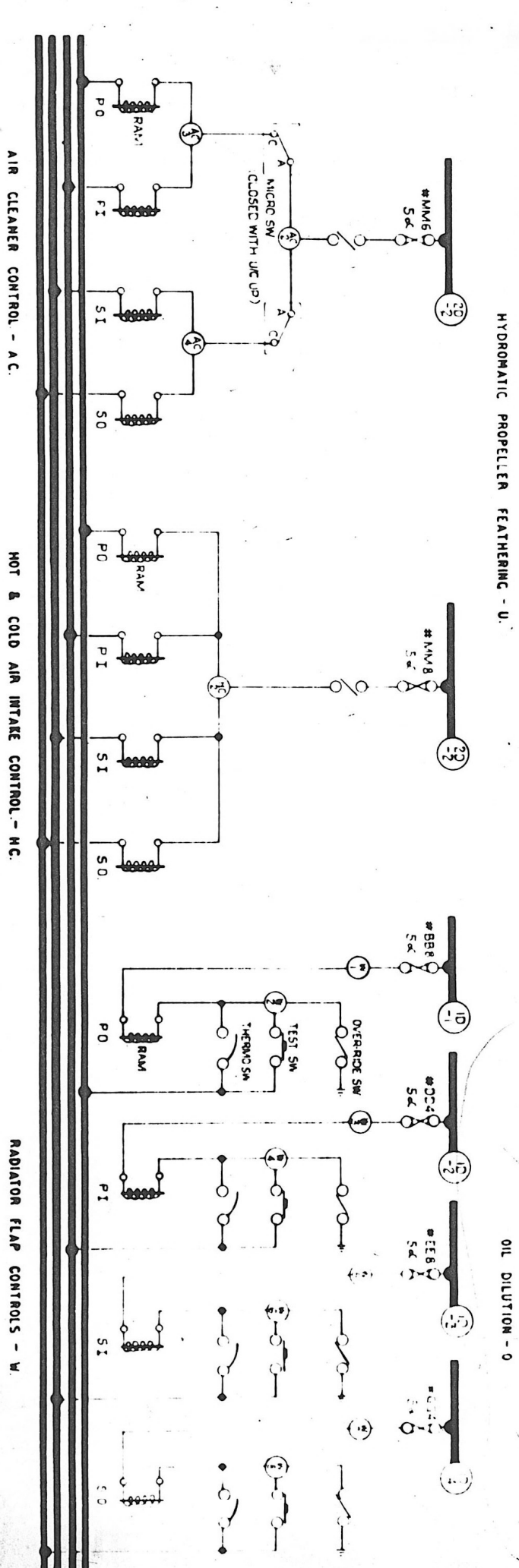
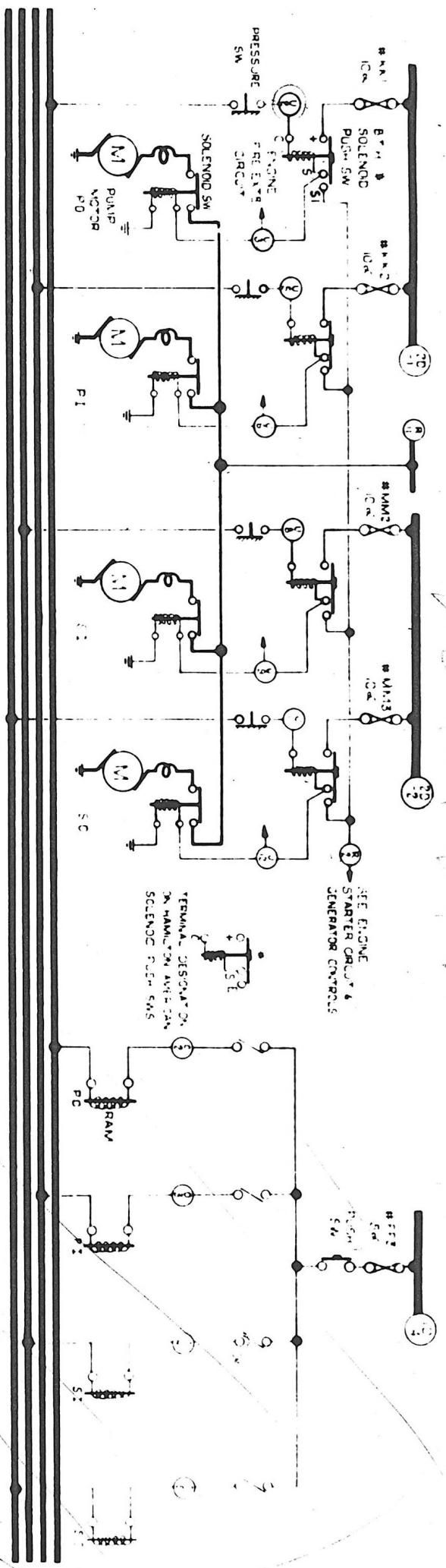

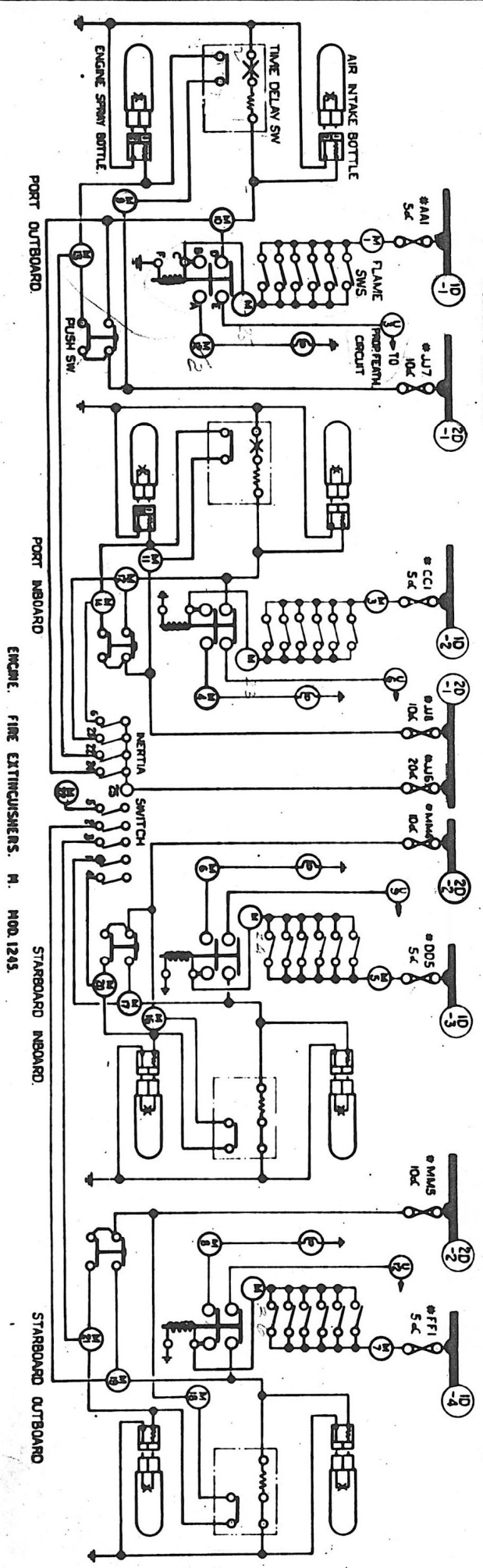
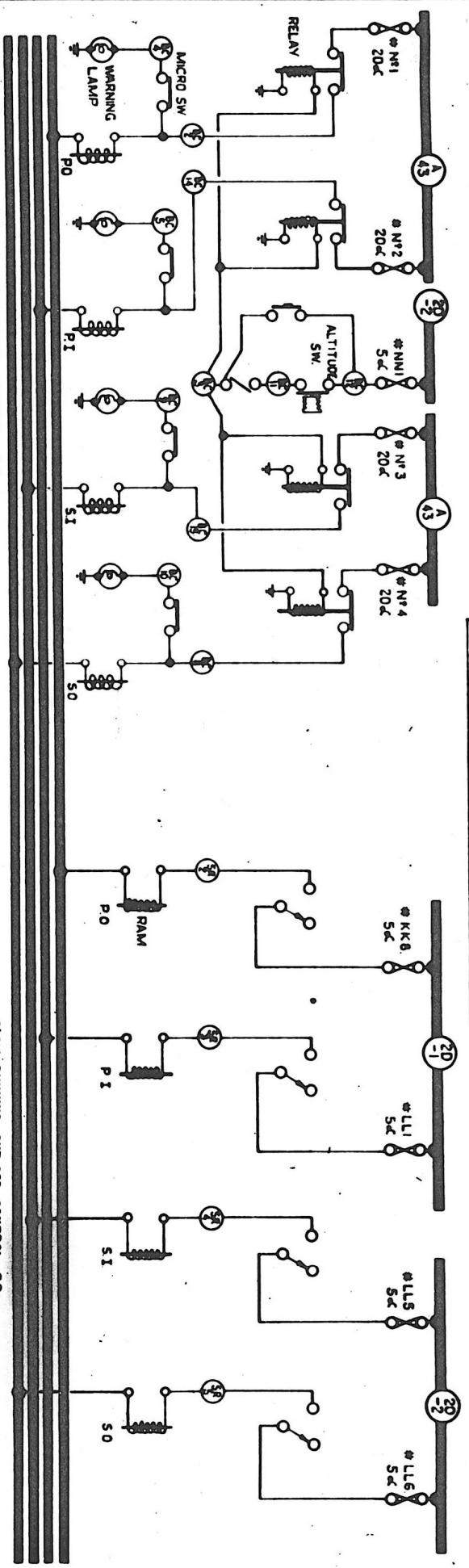

**ELECTRICAL SERVICES**

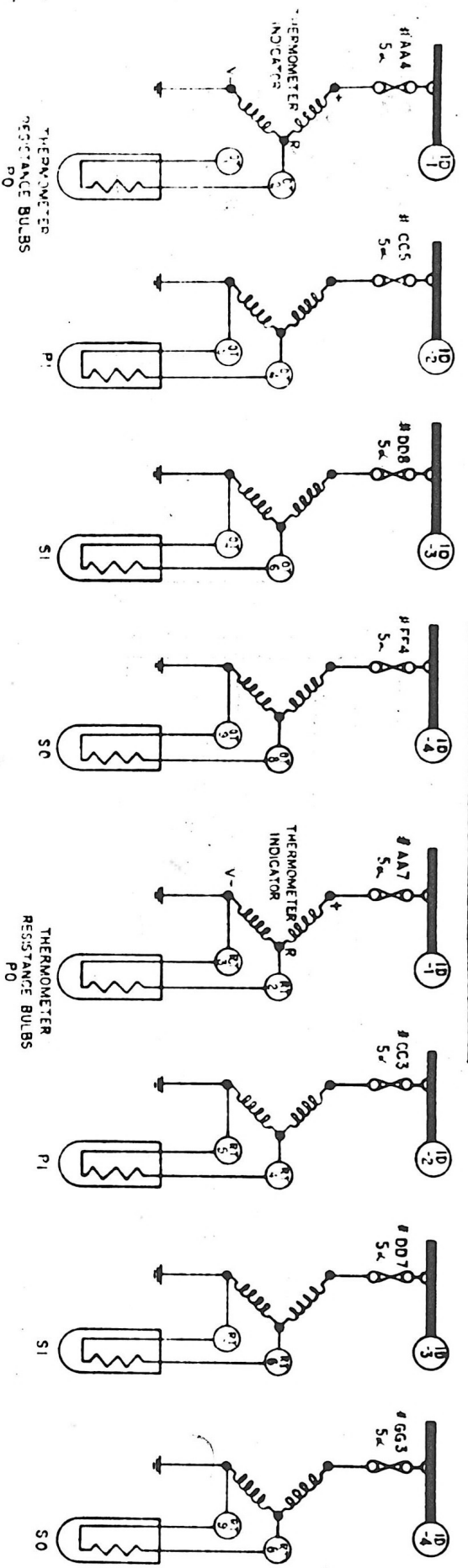

OIL TEMPERATURE THERMOMETERS - OT.

RADIATOR TEMPERATURE THERMOMETERS - RT.

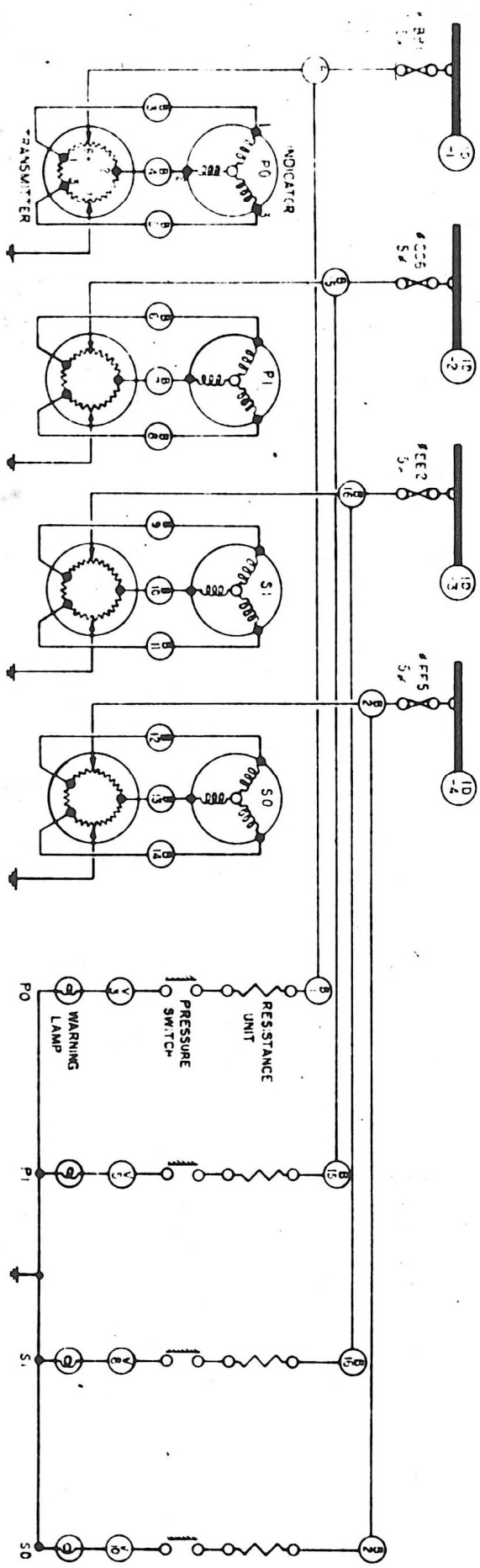

OIL PRESSURE INDICATORS - O.I.

FUEL PRESSURE WARNING LAMPS - F.P.

**THEORETICAL DIAGRAM**

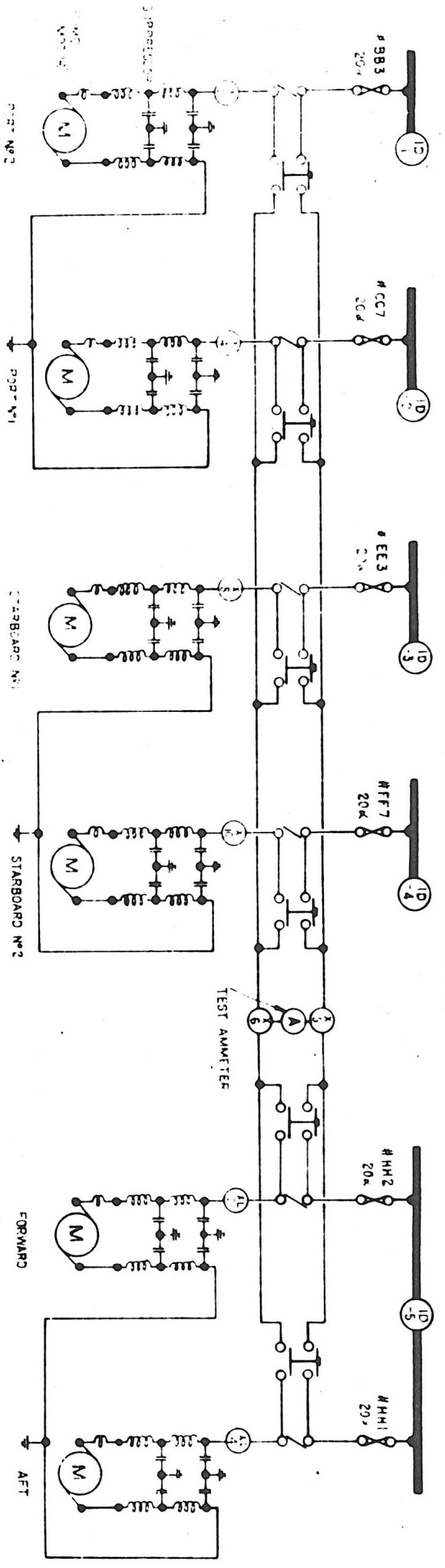

FUEL PUMPS - X.

FUEL PUMPS FOR LONG RANGE TANKS - XL.

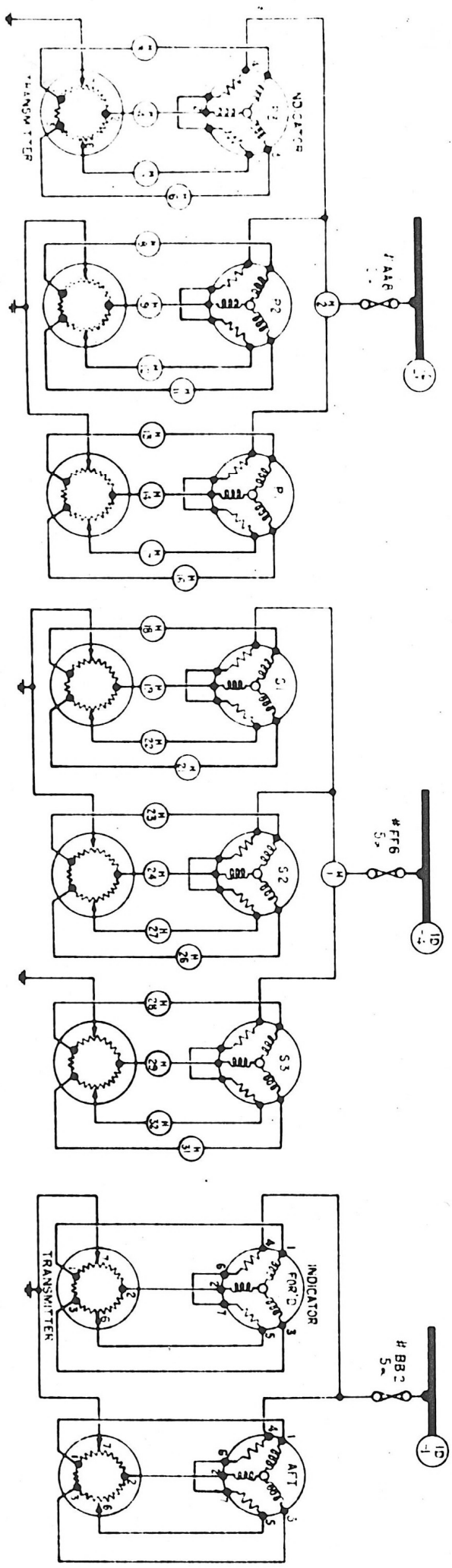

FUEL CONTENTS GAUGES - H

FUEL CONTENTS GAUGES FOR LONG RANGE TANKS.

ELECTRICAL SERVICES.

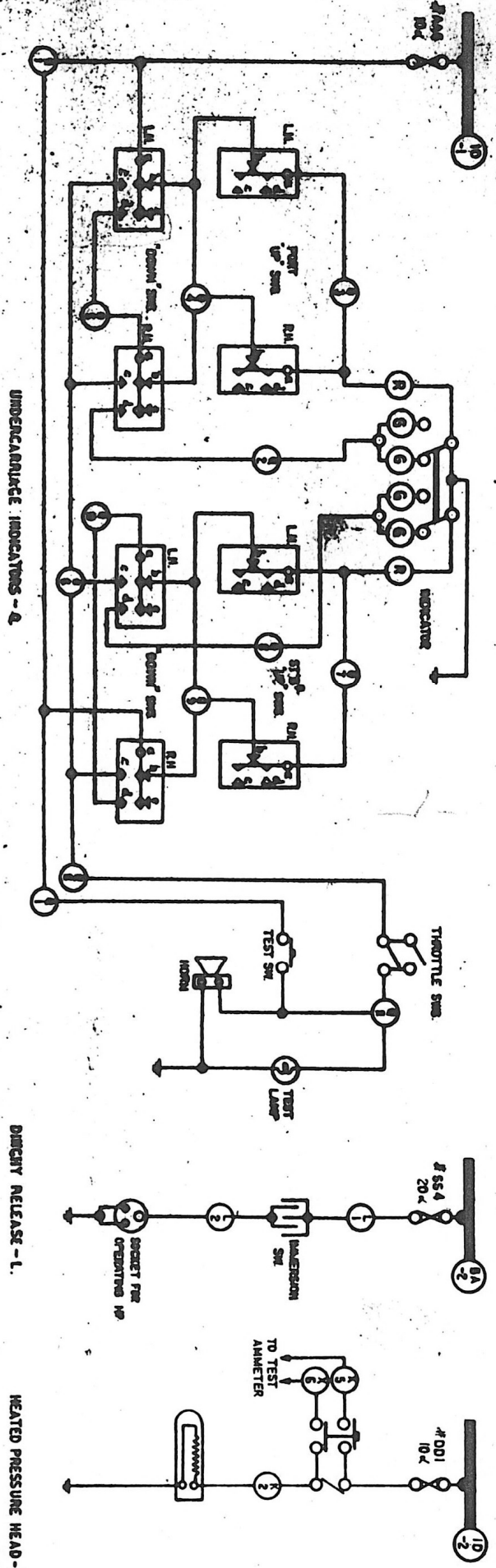
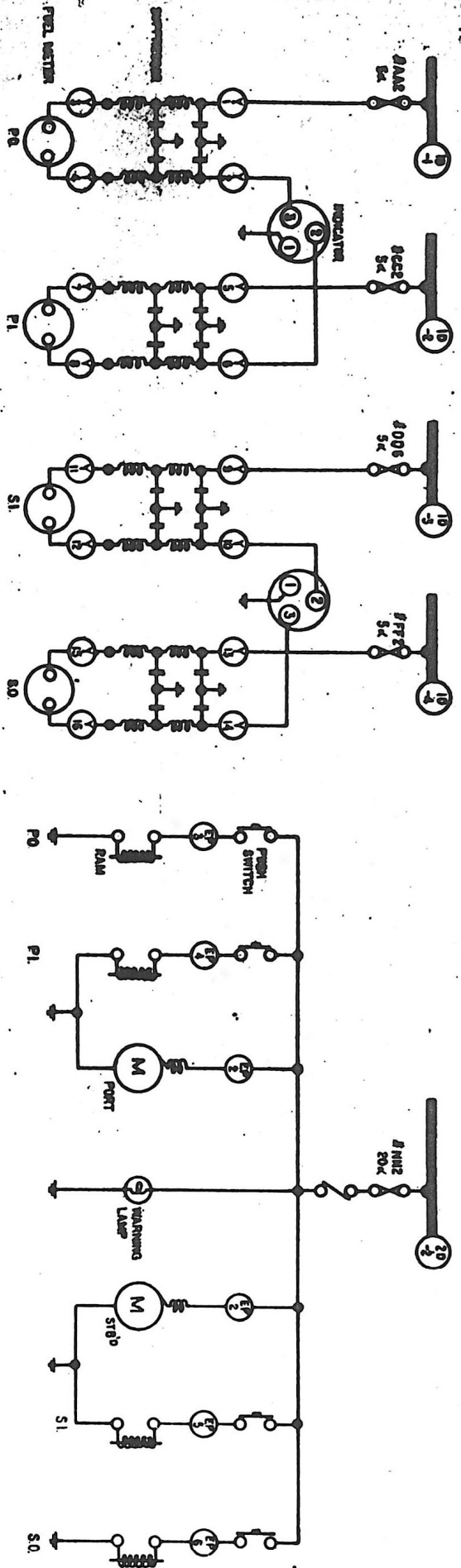

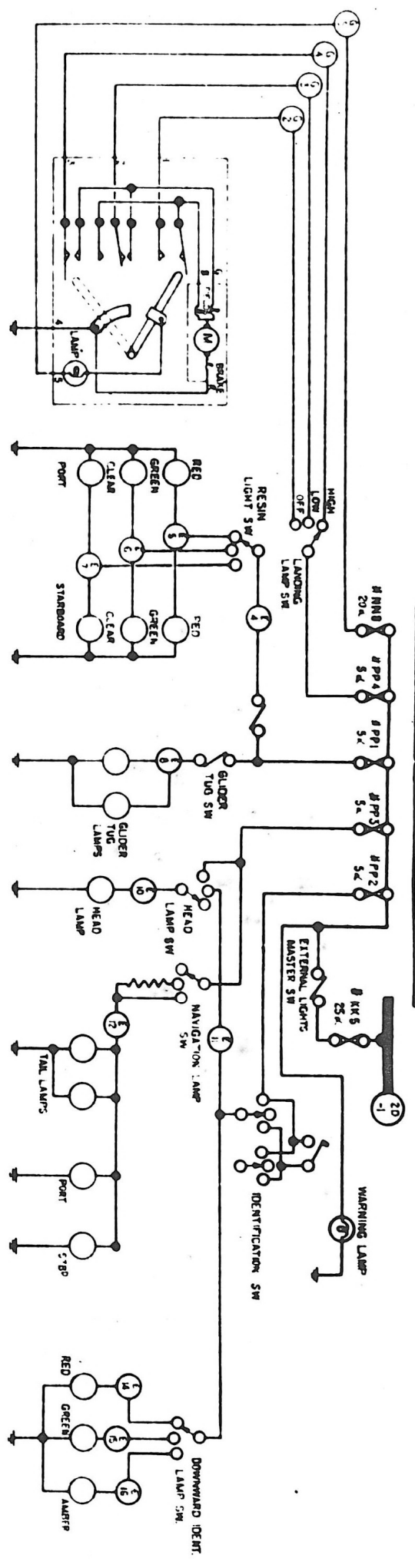

LANDING LAMP - C

RESIN LIGHTS - E

GLIDER LIGHTS - E

NAVIGATION LAMPS - E

FORMATION KEEPING LAMPS - E

IDENTIFICATION LAMPS - E

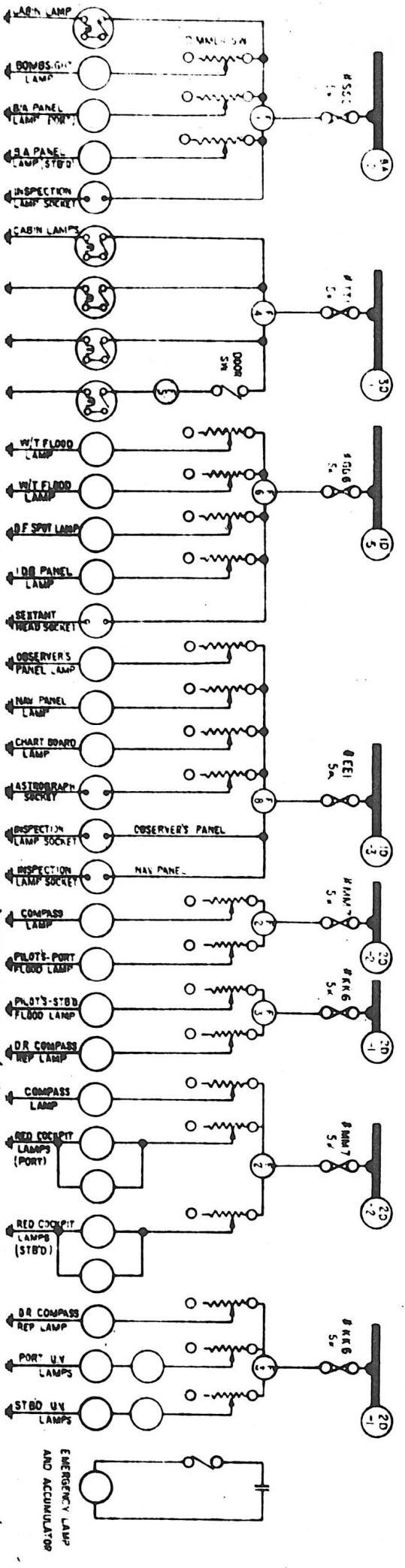

GENERAL LIGHTING - F

PILOT'S EQUIPMENT PRIOR TO MOD. 165

PILOT'S EQUIPMENT AFTER MOD. 165

ELECTRICAL SERVICES.







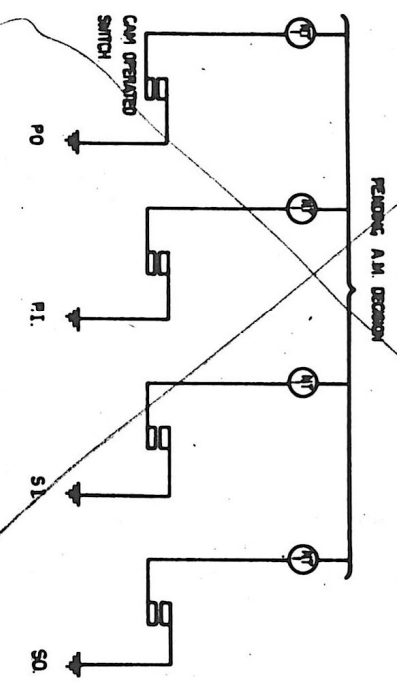

NO-TORQUE WARNING LIGHTS - N.T.

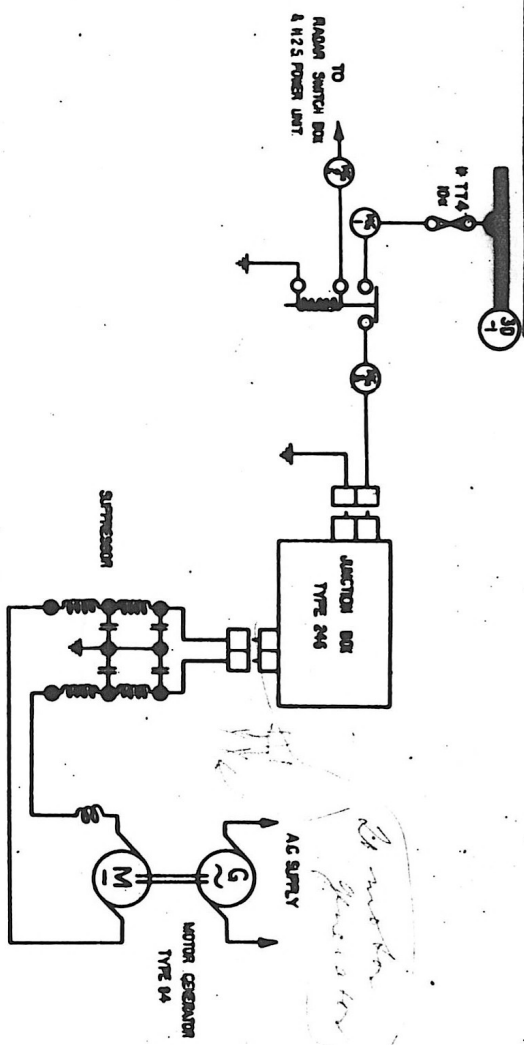

MOTOR GENERATOR FOR SCANNING UNIT - M.G.

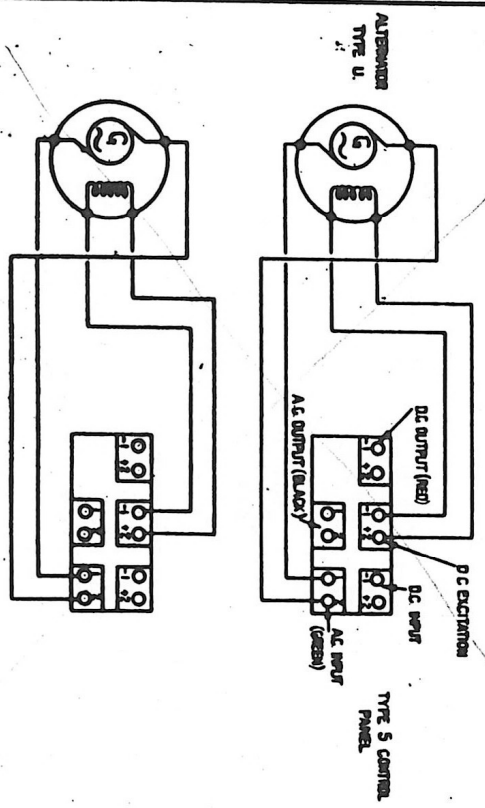

ALTERNATOR CIRCUIT

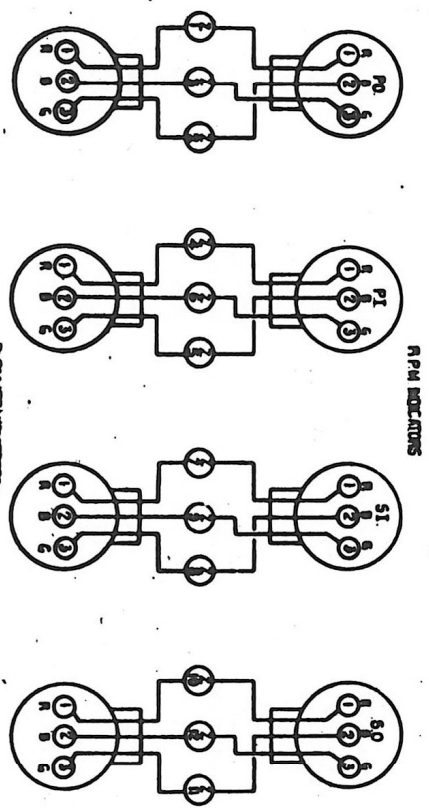

R.P.M. INDICATORS

CIRCUIT SYMBOL INDICATIONS - 2

TITLE	PORT OUTBOARD ENGINE EQUIPMENT	CON. REF.	6.P.	PORT INBOARD ENGINE EQUIPMENT	CON. REF.	4.P.	CON. REF.	WING ROOT BREAK	CON. REF.	2.P.	CON. REF.	1.D.B.

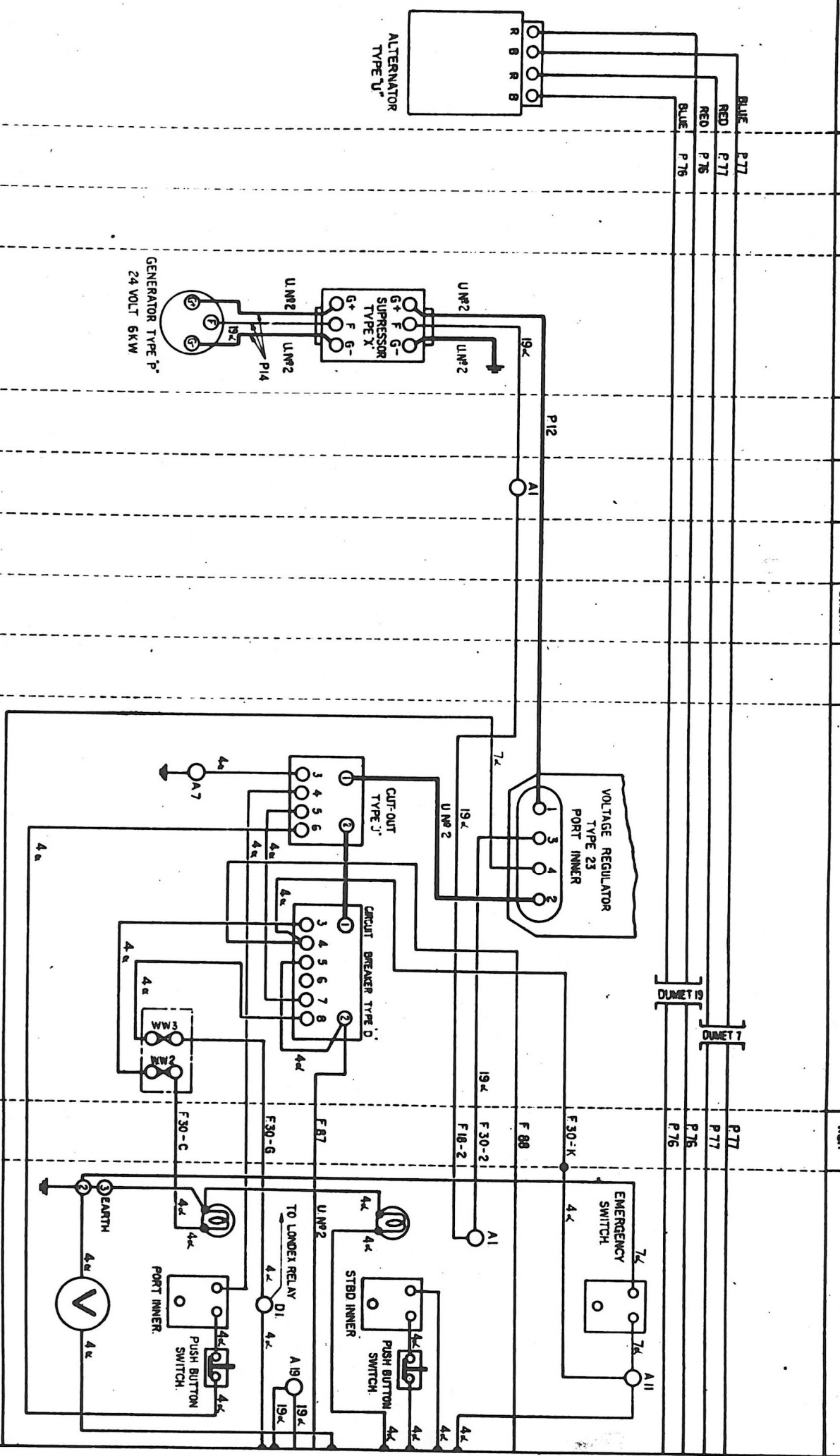

GENERATOR CONTROLS & ALTERNATOR SUPPLY

P1 C B 17 175

EQUIPMENT	COM. REF.	S.P.	COM. REF.	WING ROOT BREAK.	COM. REF.	S.P.	COM. REF.	STBD. INBOARD ENGINE EQUIPMENT	7.P.	COM. REF.	STBD. OUTBOARD ENGINE EQUIPMENT
PLUGGING BOARD											
TO FORWARD CONTROL PANEL TYPE 5											
TO AFT CONTROL PANEL TYPE 5											
VOLTAGE REGULATOR STAND BY INNER											
CUT-OUT TYPE 'J'											
CIRCUIT BREAKER TYPE 'D'											
ACCUMLATORS											
GROUND STARTER SOCKET											
MASTER REGULATOR TYPE 'X'											
MASTER SWITCH											
MASTER RELAY											
GENERATOR TYPE 'P' 24 VOLT 6 K.W.											
ALTERNATOR TYPE 'V'											

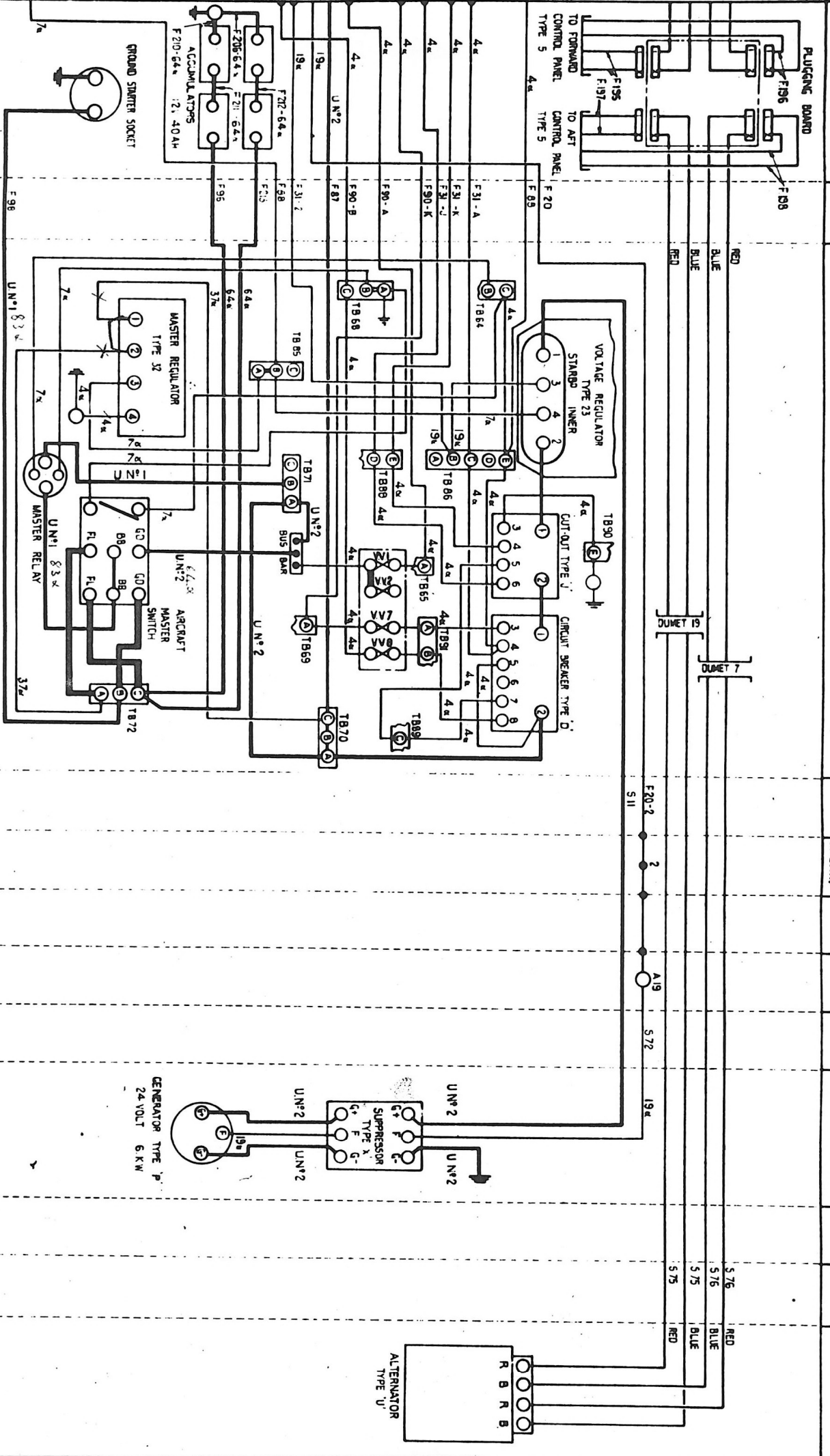

GENERAL SERVICES

FIG. 3

ENGINE STARTER, BOOSTER & IGNITION - R & C.

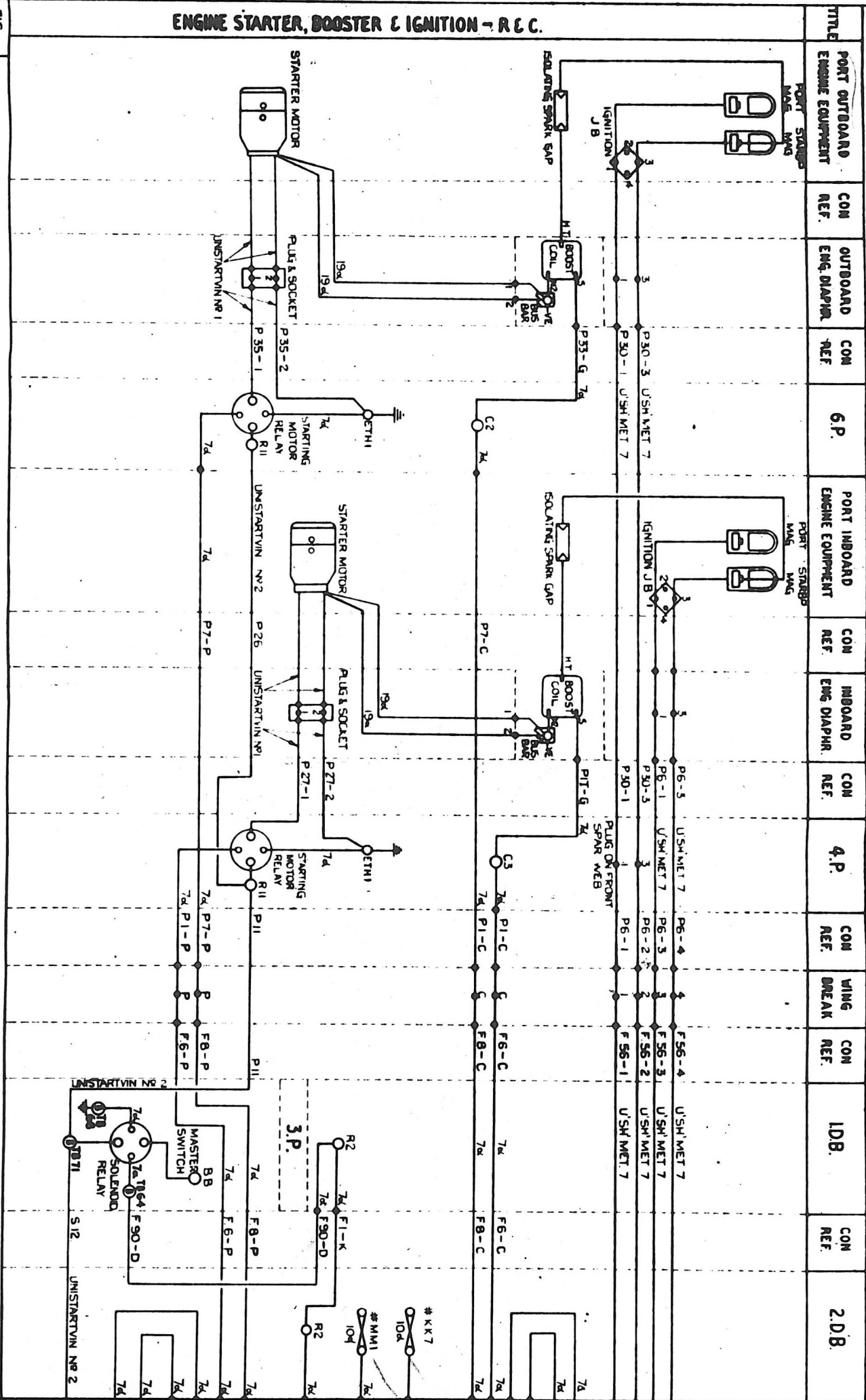
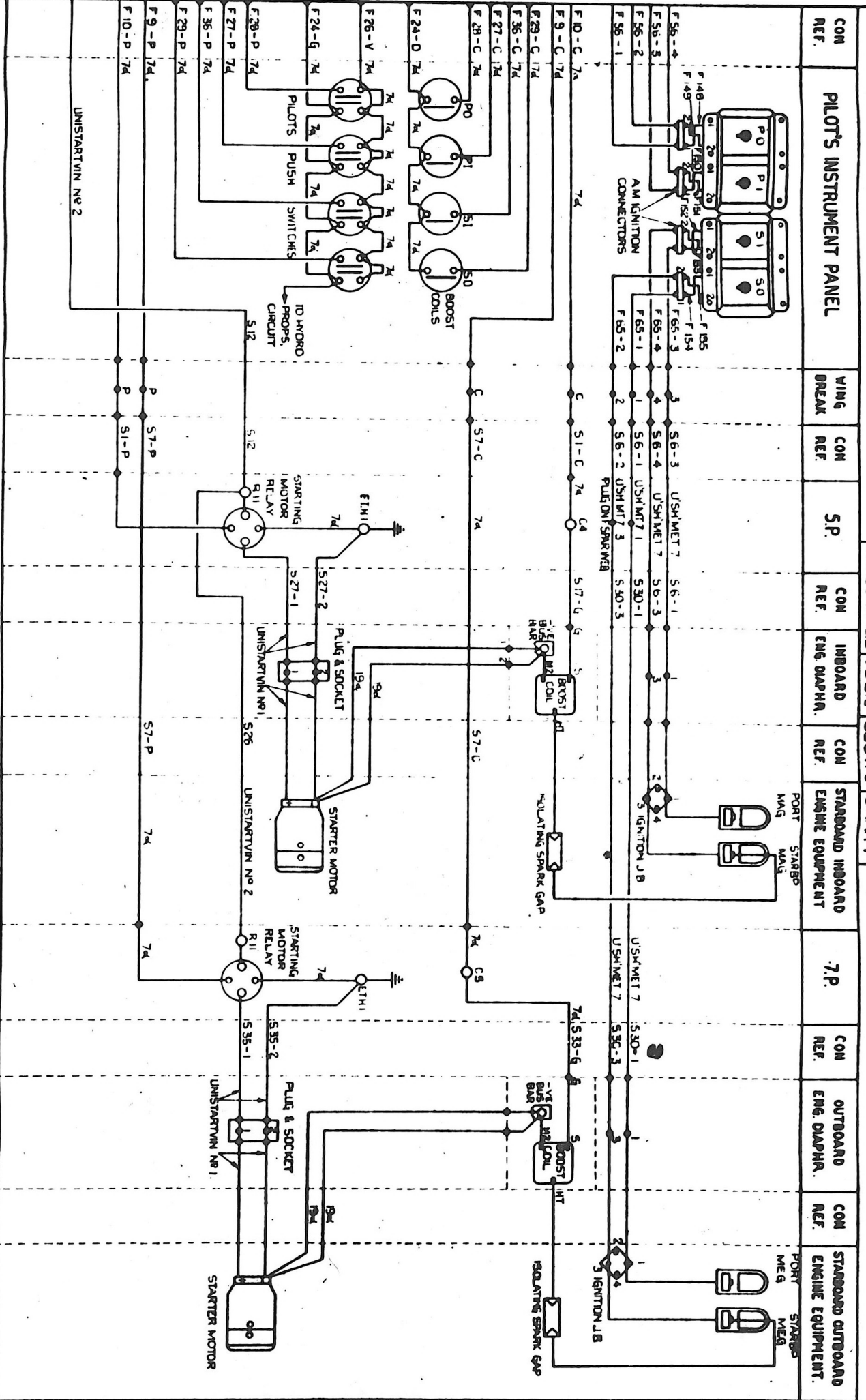

FIG. 4

ROUTING CHART



GENERAL SERVICES

FIG 4



COM REF.	PILOT'S INSTRUMENT PANEL	WING BREAK	COM REF.	S.P.	COM REF.	INBOARD ENGINE DIAPHR.	COM REF.	STARBOARD INBOARD ENGINE EQUIPMENT	7.P.	COM REF.	OUTBOARD ENGINE DIAPHR.	COM REF.	STARBOARD OUTBOARD ENGINE EQUIPMENT
----------	--------------------------	------------	----------	------	----------	------------------------	----------	------------------------------------	------	----------	-------------------------	----------	-------------------------------------

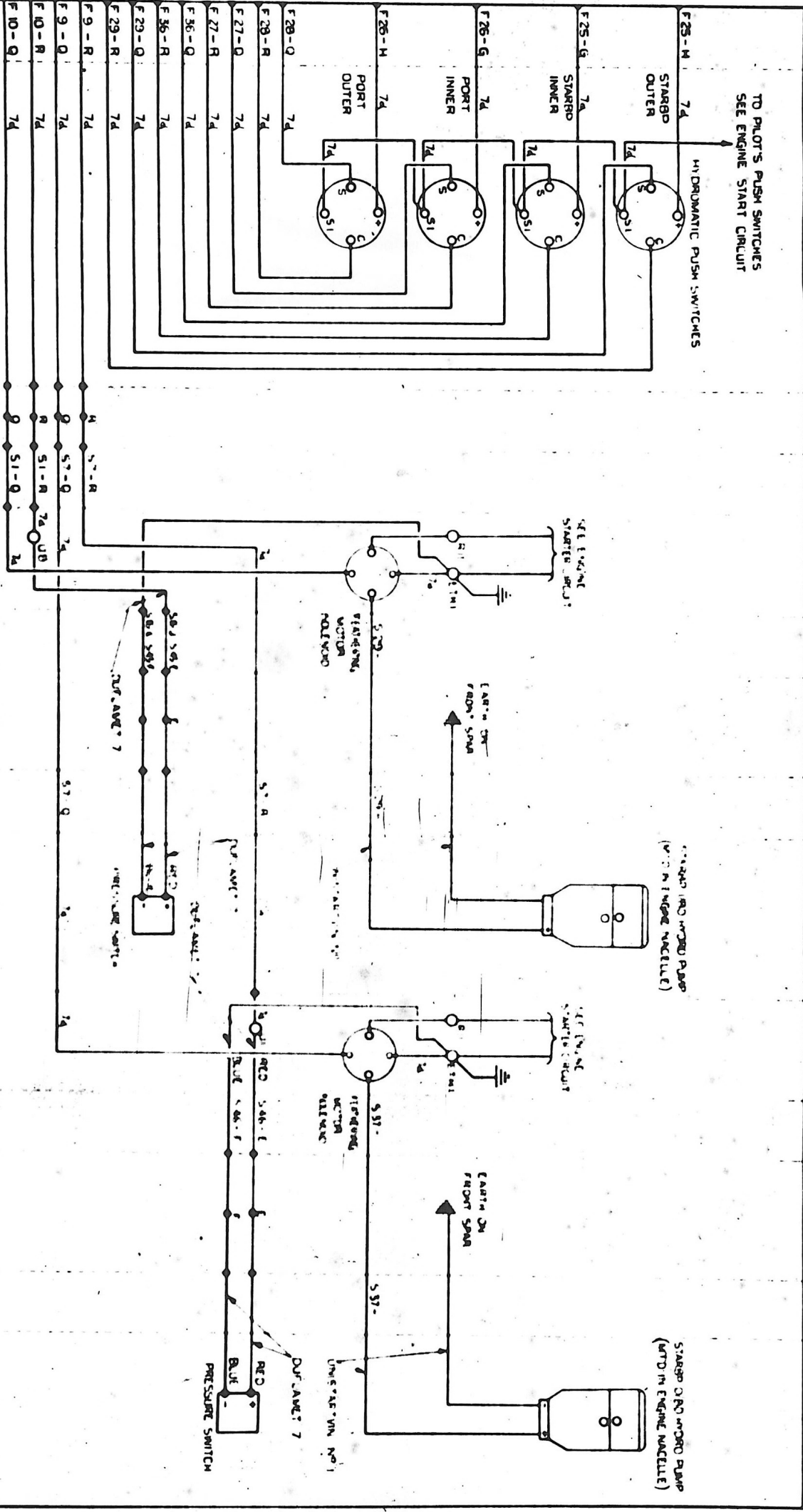

GENERAL SERVICES.



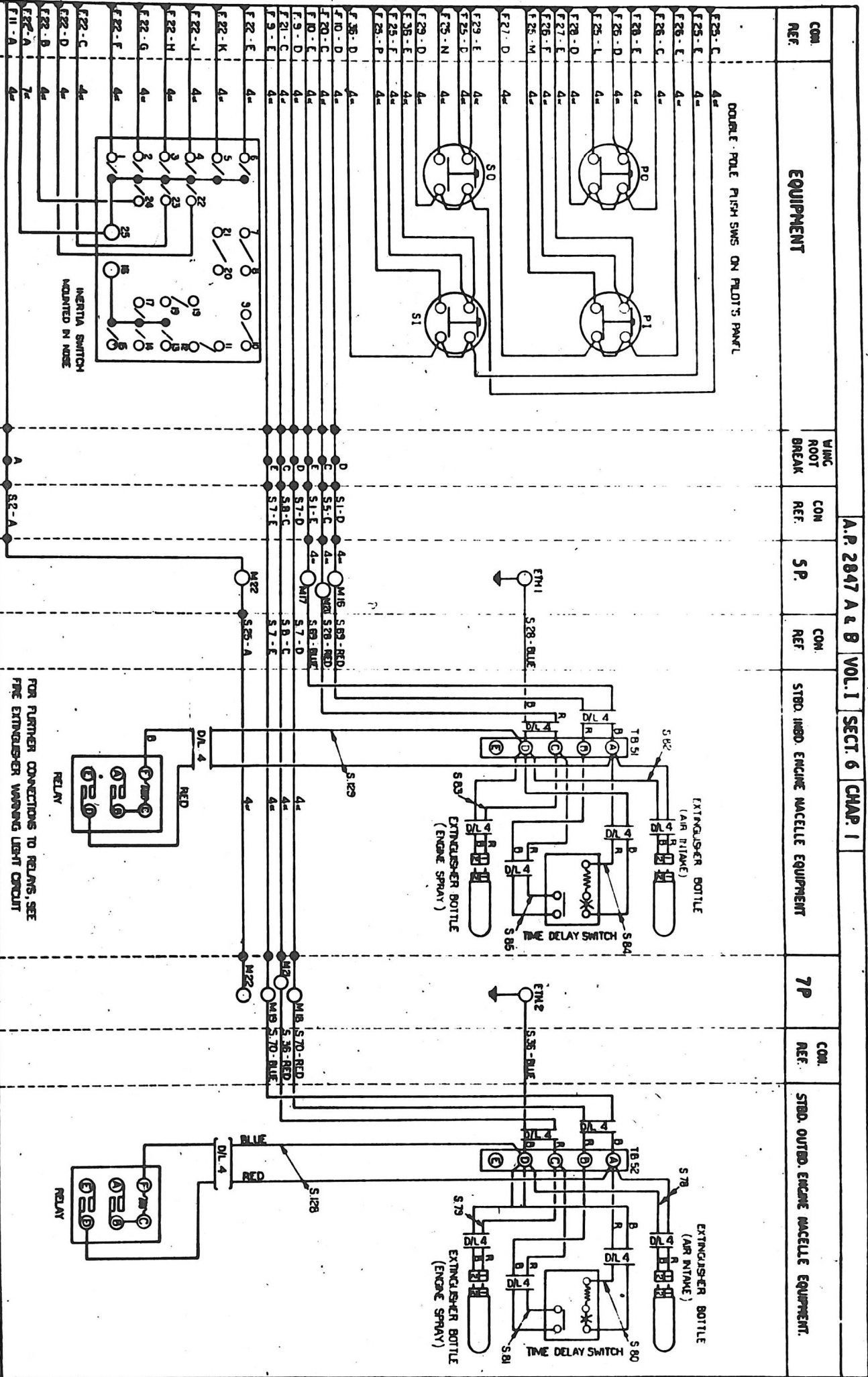

GENERAL SERVICES



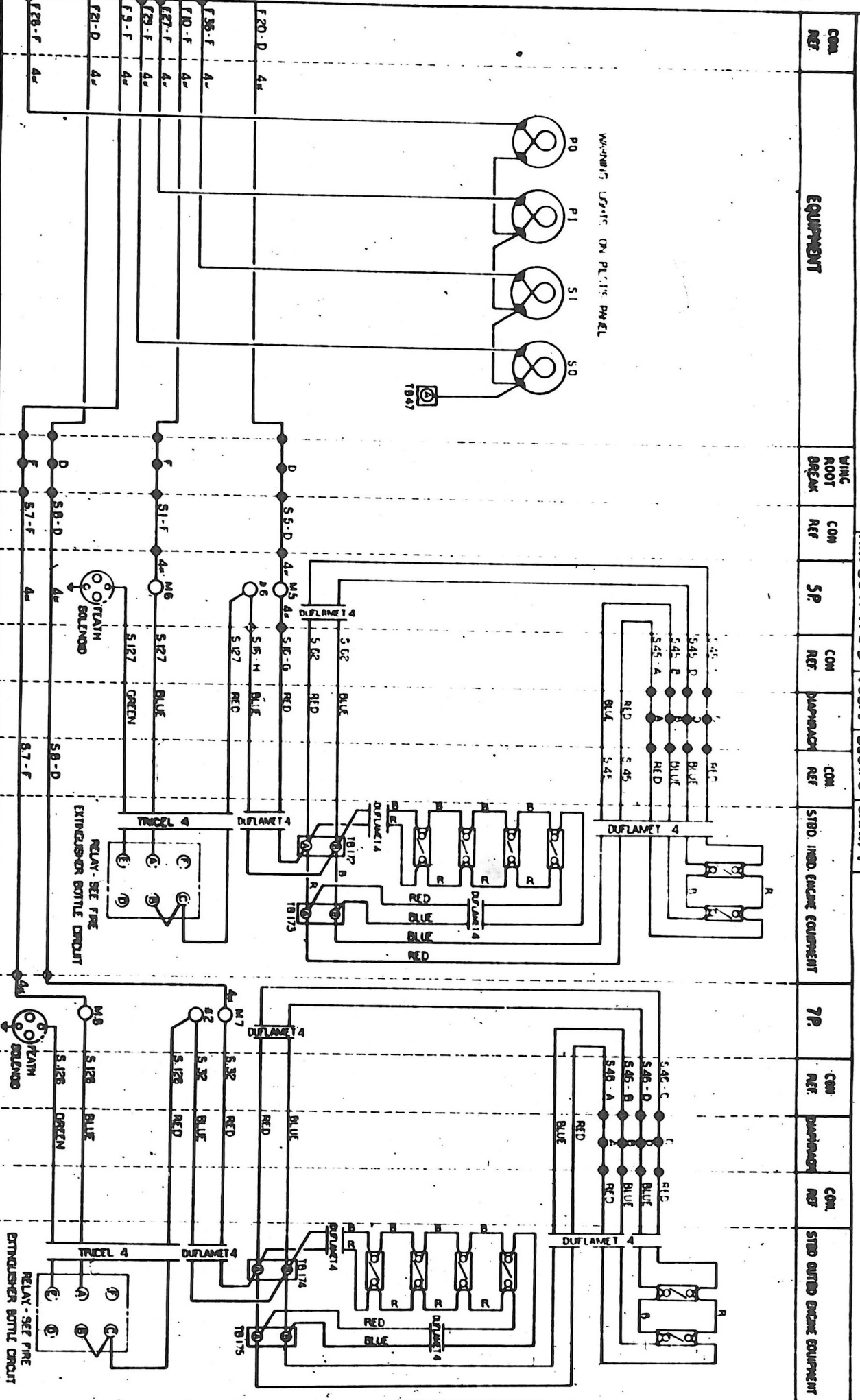

GENERAL SERVICES

TITLE	ENGINE EQUIPMENT	CON REF.	OUTBOARD ENGINE DIAGRAM	CON REF.	6 P.	ENGINE EQUIPMENT	CON REF.	INBOARD ENGINE DIAGRAM	CON REF.	4 P.	CON REF.	VINC ROOT BREAK	CON REF.	LOG.	CON REF.
RADIATOR TEMPERATURE THERMOMETERS	RADIATOR TEMPERATURE RESISTANCE UNIT PORT OUTBOARD	CON REF.		CON REF.	6 P.	RADIATOR TEMPERATURE RESISTANCE UNIT PORT INBOARD	CON REF.		CON REF.	4 P.	CON REF.	VINC ROOT BREAK	CON REF.		CON REF.
OIL TEMPERATURE THERMOMETERS O.T.	OIL TEMPERATURE RESISTANCE UNIT PORT OUTBOARD	CON REF.		CON REF.	6 P.	OIL TEMPERATURE RESISTANCE UNIT PORT INBOARD	CON REF.		CON REF.	4 P.	CON REF.	VINC ROOT BREAK	CON REF.		CON REF.

ROUTING CHART



AP 2047 A B B		VOL I		SECT 6		CHAP 1										
TIME	ENGINE EQUIPMENT	CON REF.	OUTBOARD ENGINE EQUIPMENT	CON REF.	6 P	ENGINE EQUIPMENT	CON REF.	INBOARD ENGINE EQUIPMENT	CON REF.	4 P	WING ROOT BREAK	CON REF.	I.D.B.	CON REF.	2 D.B.	CON REF.

OIL PRESSURE INDICATORS B

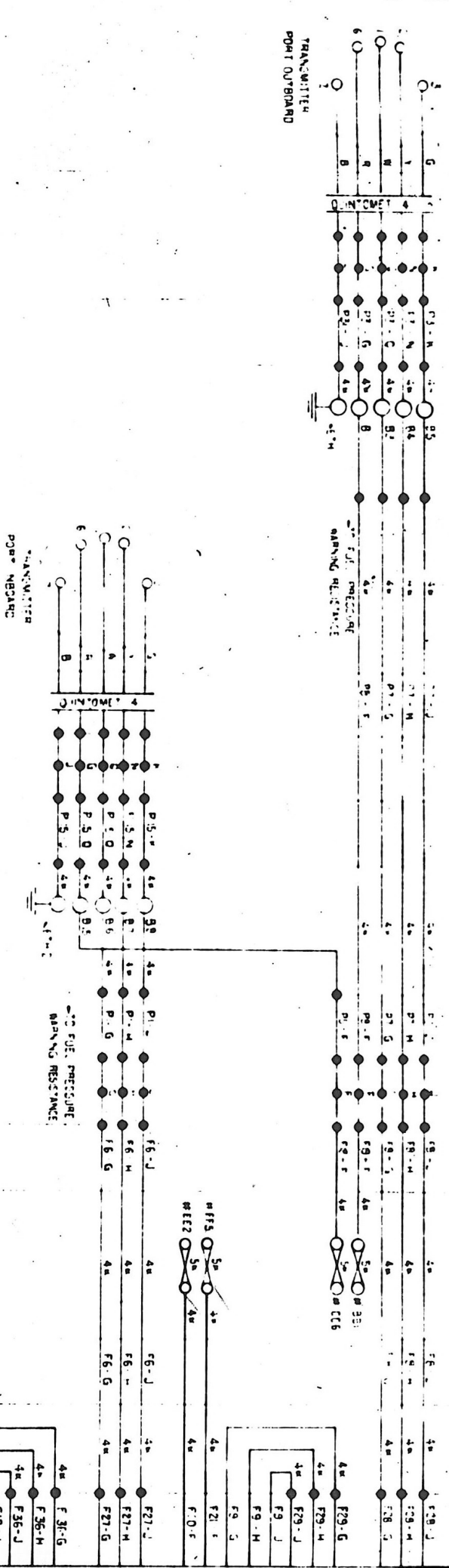

FUEL FLOWMETER INDICATORS Y

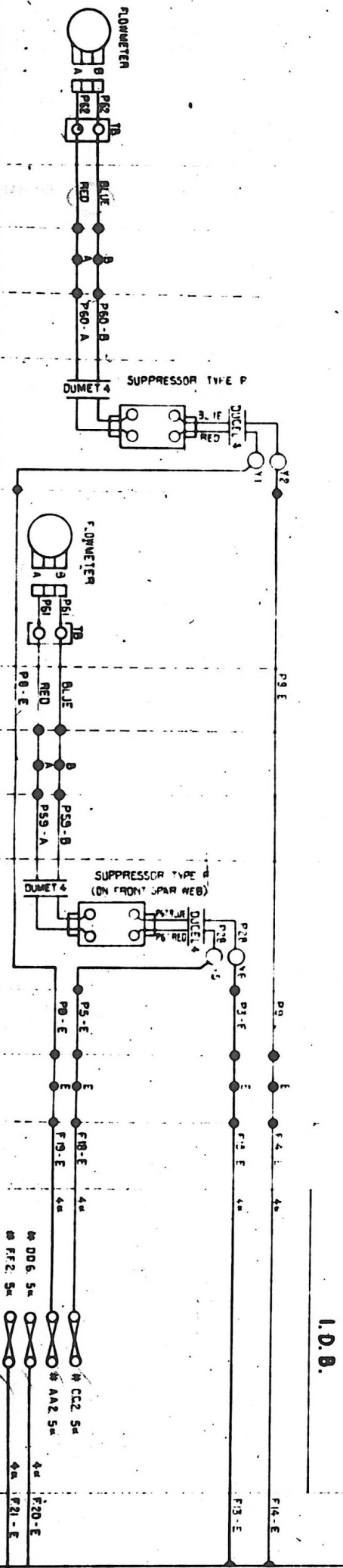
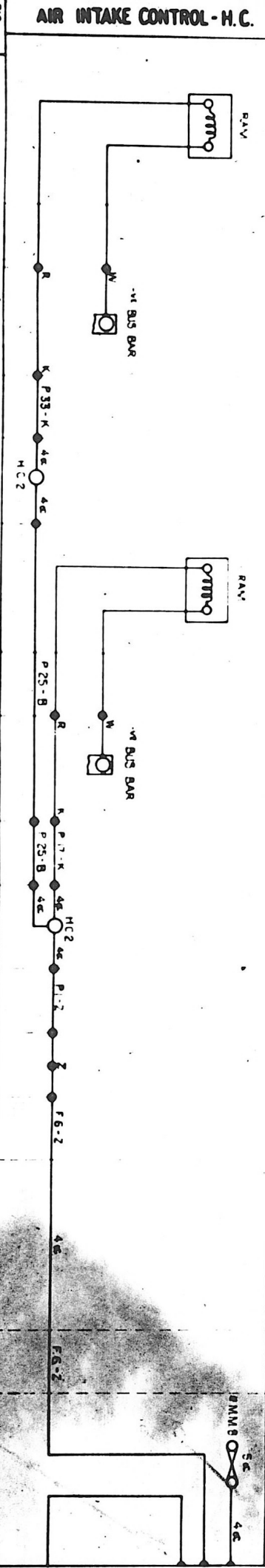
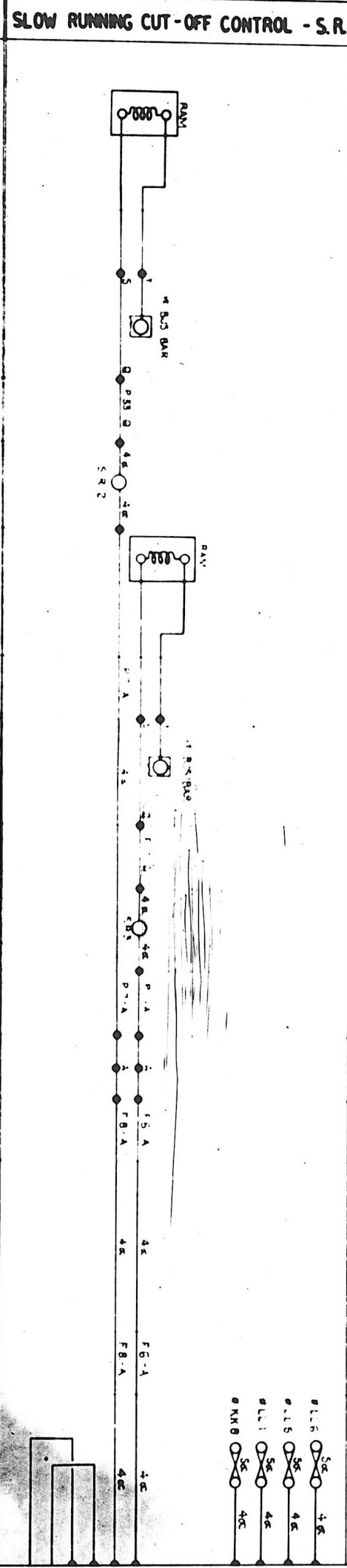
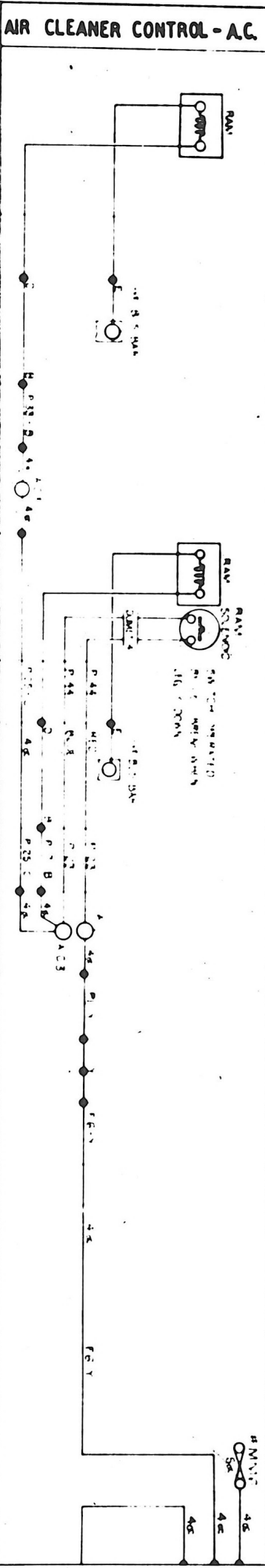

FIG. 9 ROUTING CHART



TITLE	PORT OUTBOARD ENGINE EQUIPMENT	CON REF	OUTBOARD ENGINE DIAGRAM	CON REF	6 P	PORT INBOARD ENGINE EQUIPMENT	CON REF	INBOARD ENGINE DIAGRAM	CON REF	4 P	WING ROOT BRK/AL	CON REF	10B	CON REF	20B
AIR INTAKE CONTROL - H.C.															
SLOW RUNNING CUT-OFF CONTROL - S.R.															
AIR CLEANER CONTROL - A.C.															





TITLE	PORT OUTBOARD ENGINE EQUIPMENT	COM. REF.	OUTBOARD ENGINE DIAGNOSIS	COM. REF.	6 P.	PORT INBOARD ENGINE EQUIPMENT	COM. REF.	INBOARD ENGINE DIAGNOSIS	COM. REF.	4 P.	WARRANTY BREAK.	COM. REF.	1 D.B.	COM. REF.	2 D.B.

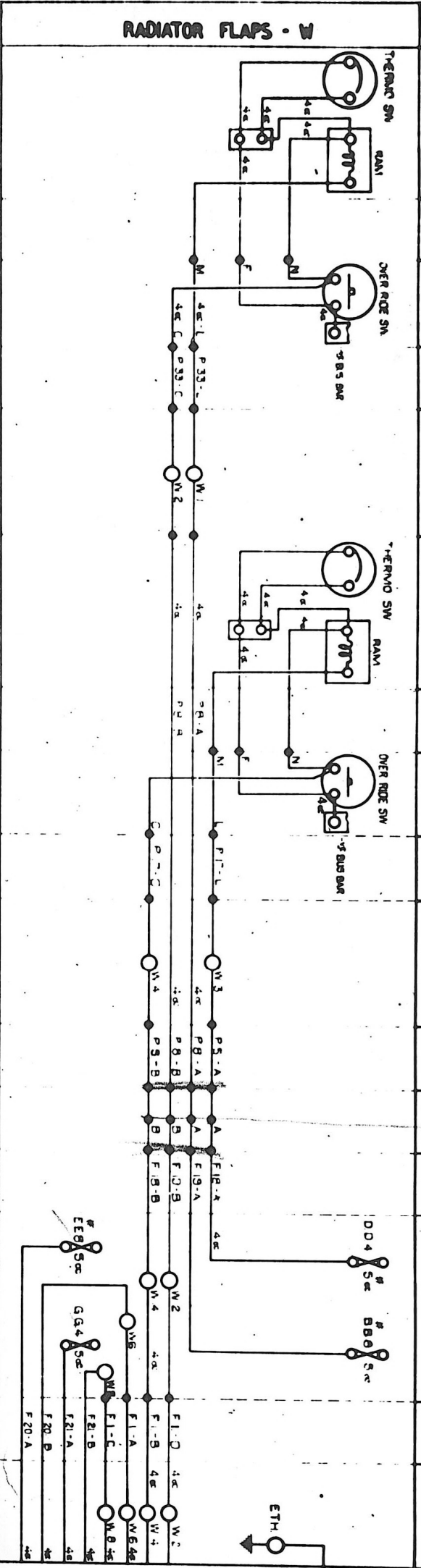

3 P. COM. REF. 1 D.B. COM. REF. 2 D.B.

SUPERCHARGER CONTROL - B.C

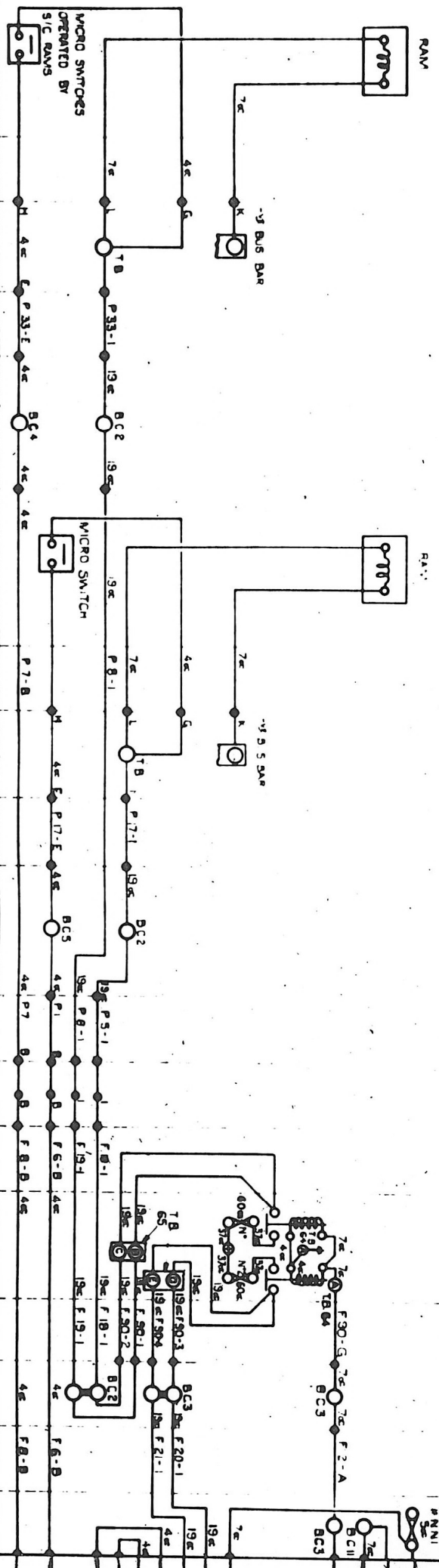

ROUTING CHART

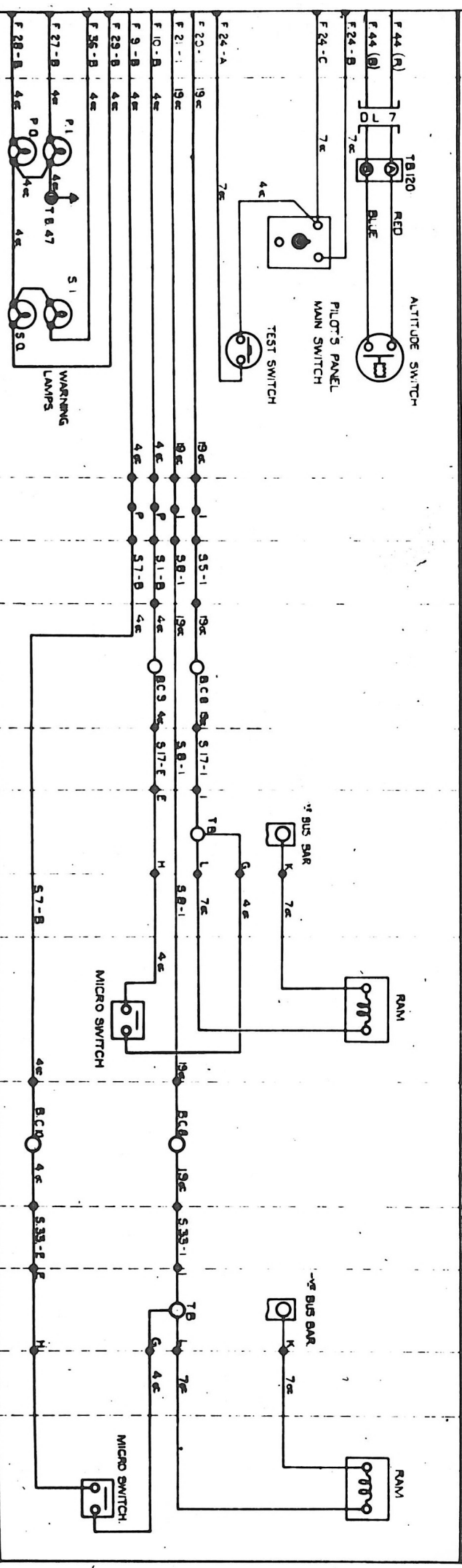
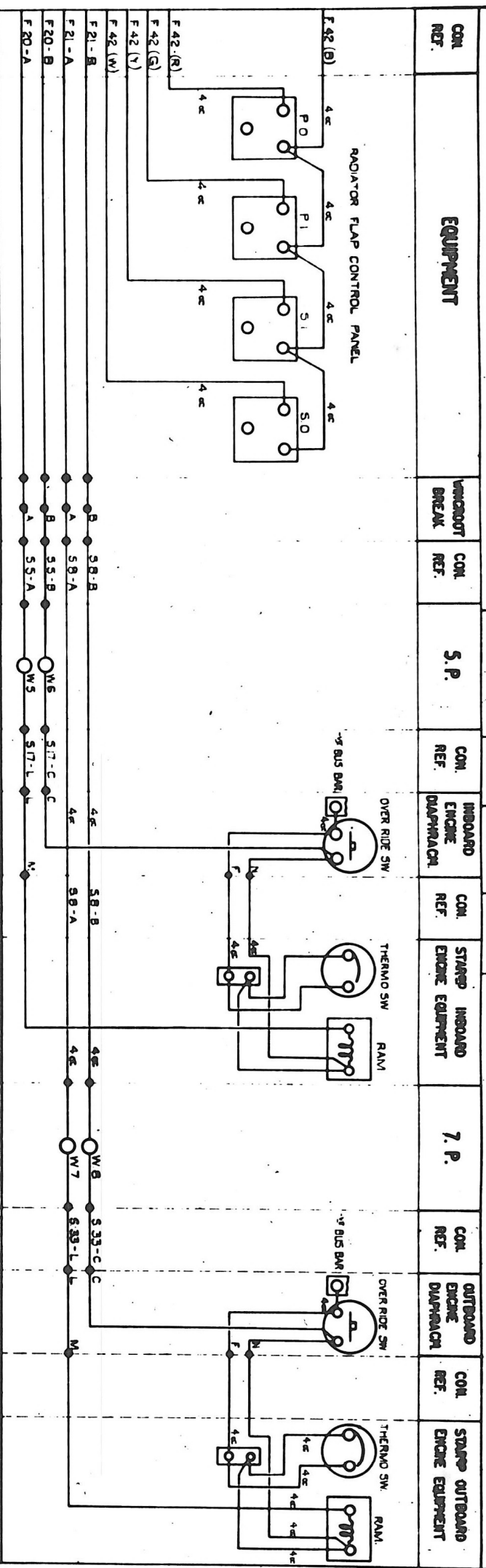

**GENERAL SERVICES.**

TITLE	PORT OUTBOARD ENGINE EQUIPMENT	CON. REF.	OUTBOARD ENGINE DIAGNOSIS	CON. REF.	6 P.	PORT INBOARD ENGINE EQUIPMENT	CON. REF.	INBOARD ENGINE DIAGNOSIS	CON. REF.	4 P.	CON. REF.	WATERCRAFT BREAK	CON. REF.	1 D.B.	CON. REF.	2 D.B.

OIL DILUTION SYSTEM '0'

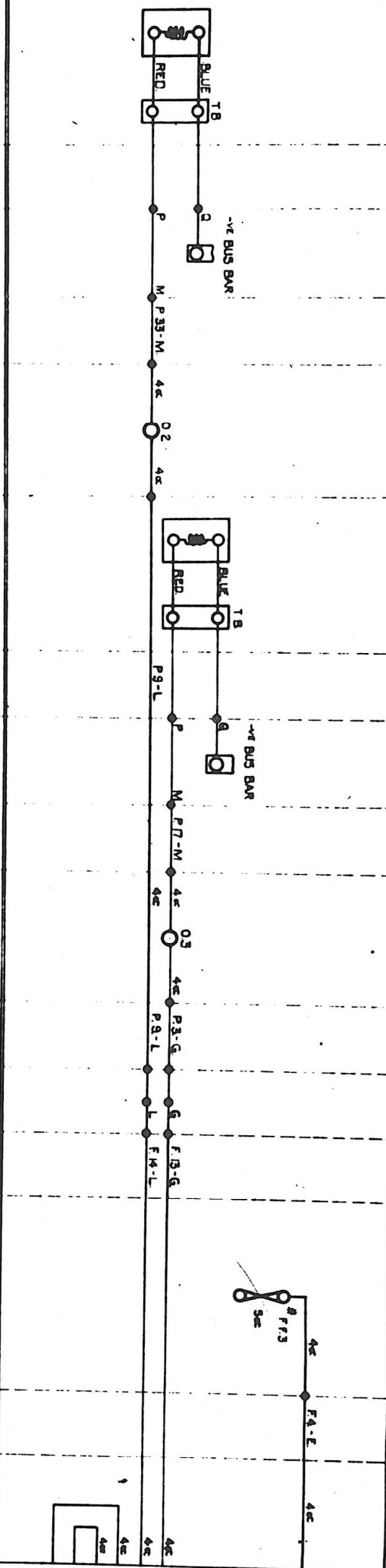

FUEL PRESSURE WARNING LIGHTS 'V'

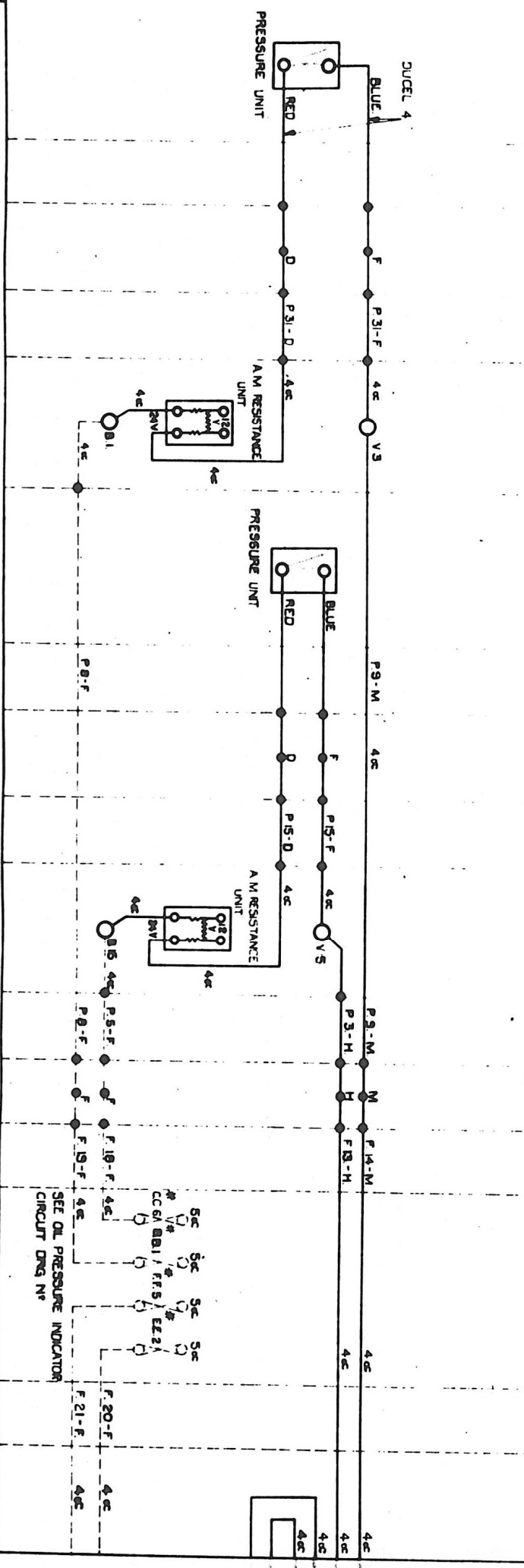

AIR OBSERVER'S PANEL

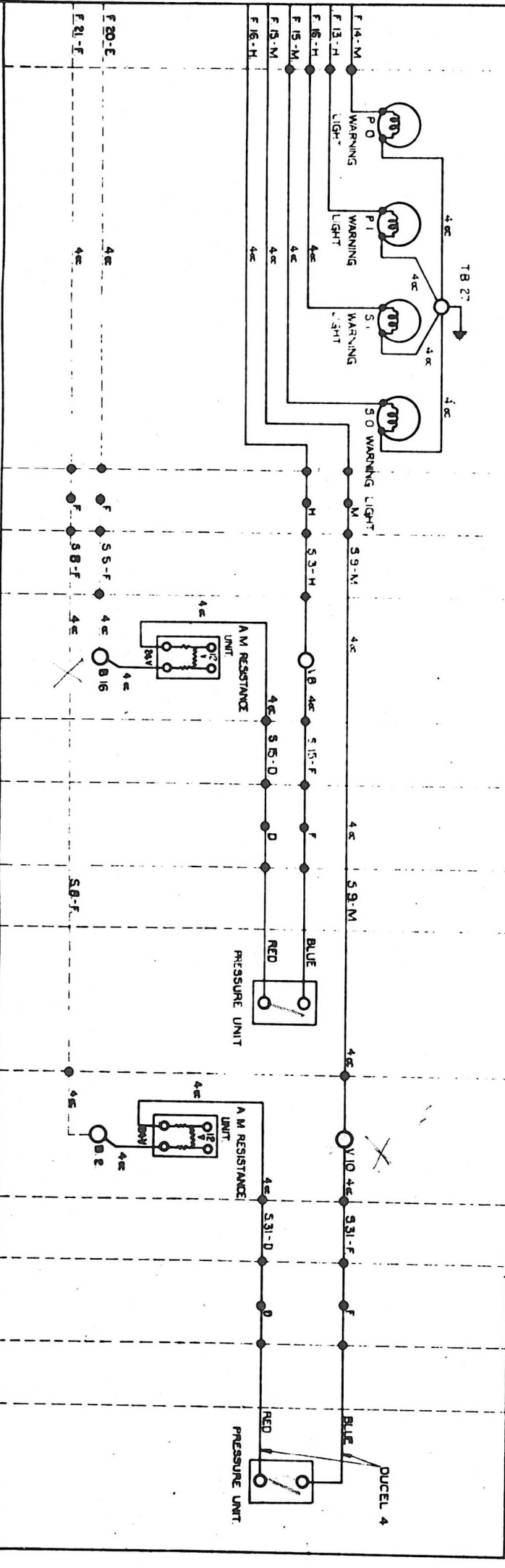
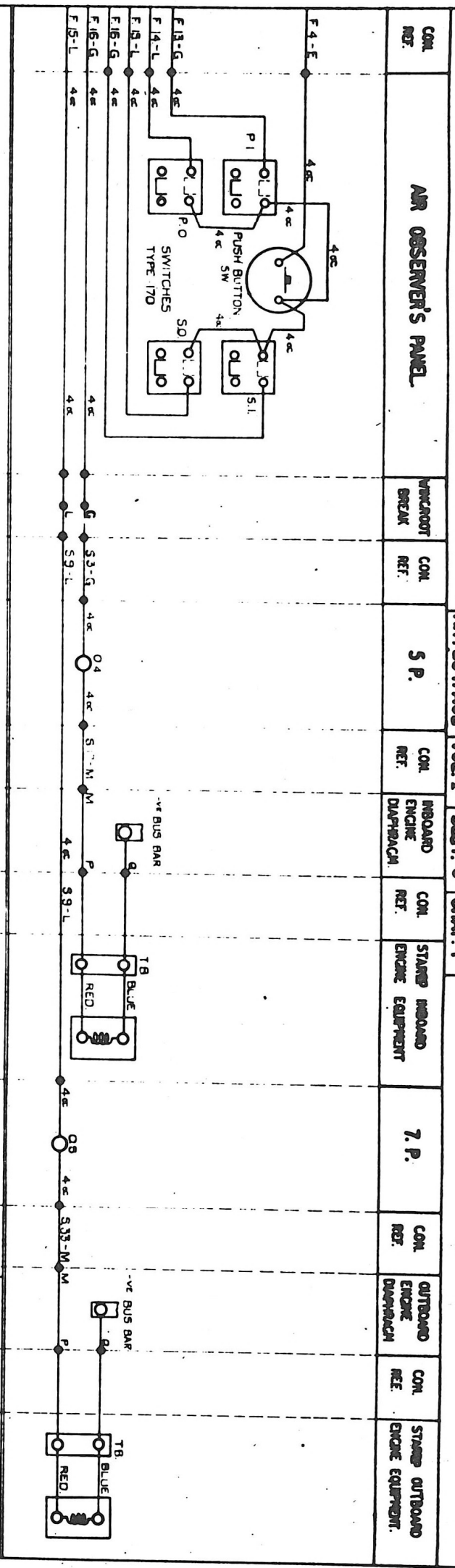

GENERAL SERVICES

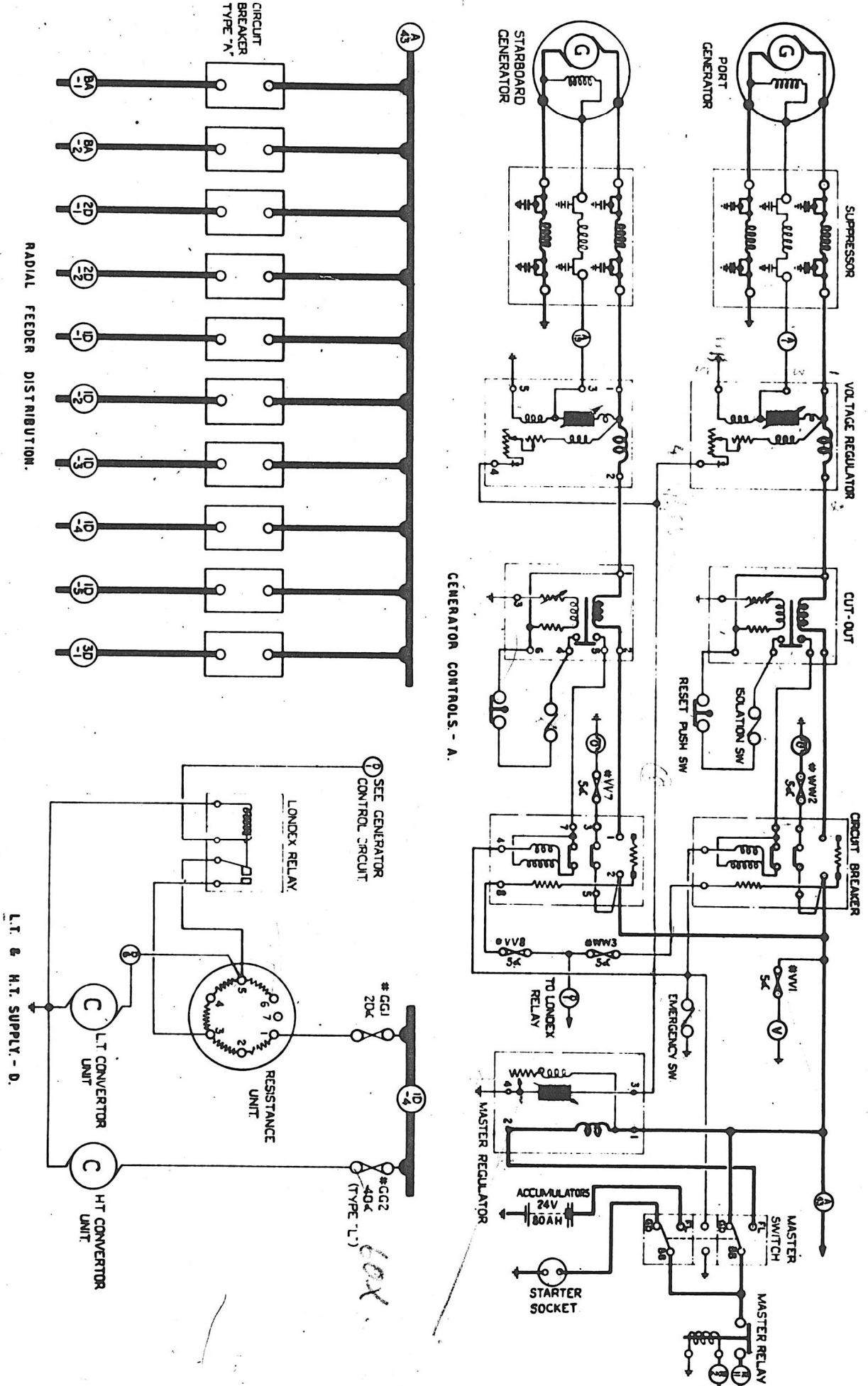

GENERATOR CONTROLS - A.

RADIAL FEEDER DISTRIBUTION.

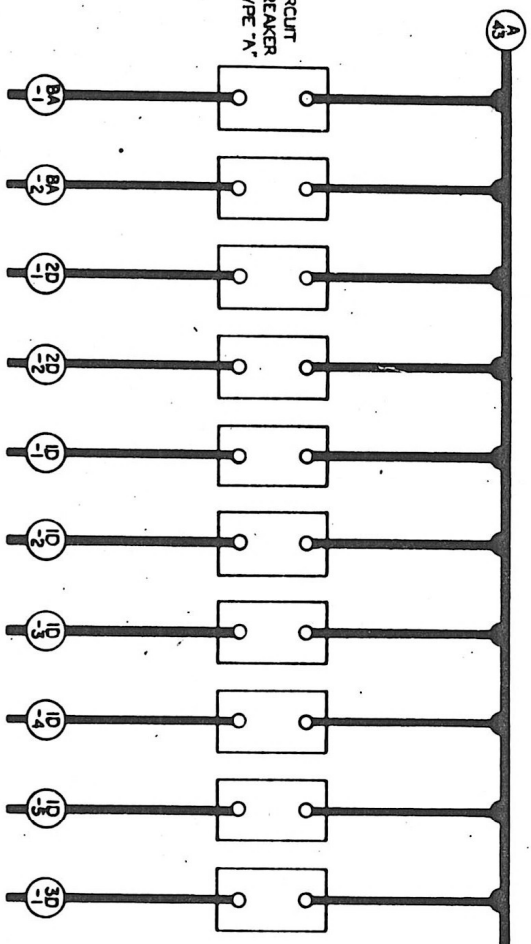

L.T. & H.T. SUPPLY - D.

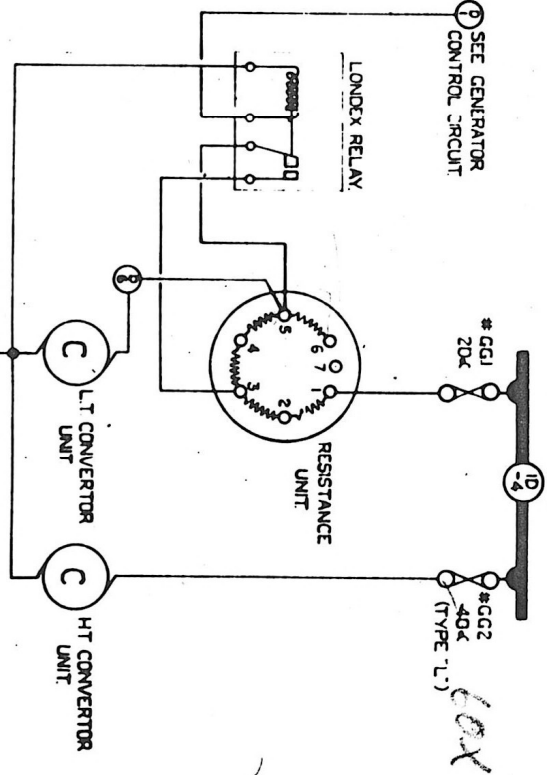

TITLE	PORT OUTBOARD ENGINE EQUIPMENT	CON. REF.	OUTBOARD ENGINE DIAPHR.	CON. REF.	6 P	PORT INBOARD ENGINE EQUIPMENT	CON. REF.	INBOARD ENGINE DIAPHR.	CON. REF.	4 P	CON. REF.	WING ROOT BREAK	CON. REF.	1 DB	CON. REF.	2 DB
-------	--------------------------------	-----------	-------------------------	-----------	-----	-------------------------------	-----------	------------------------	-----------	-----	-----------	-----------------	-----------	------	-----------	------

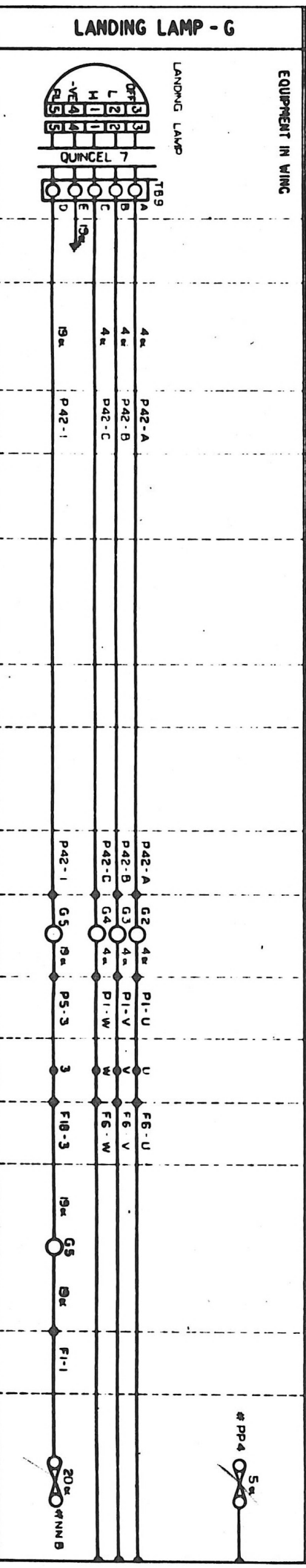
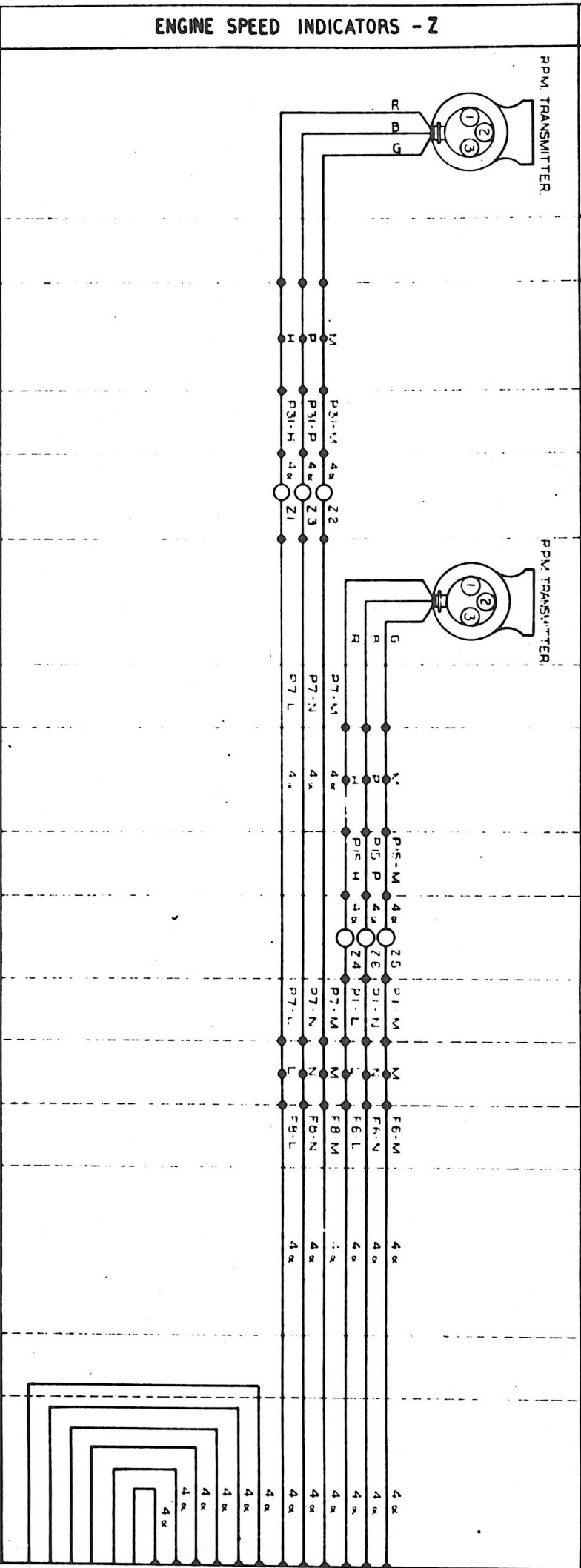

EQUIPMENT IN WING

LANDING LAMP

LANDING LAMP - 6

FIG. 13

ROUTING CHART

CON. REF.	PILOT'S PANEL	WING ROOT BREAK	CON. REF.	S P	CON. REF.	INBOARD ENGINE DIAPHR.	CON. REF.	STBD. INBOARD ENGINE EQUIPMENT	7 P	CON. REF.	OUTBOARD ENGINE DIAPHR.	CON. REF.	STBD. OUTBOARD ENGINE EQUIPMENT
-----------	---------------	-----------------	-----------	-----	-----------	------------------------	-----------	--------------------------------	-----	-----------	-------------------------	-----------	---------------------------------

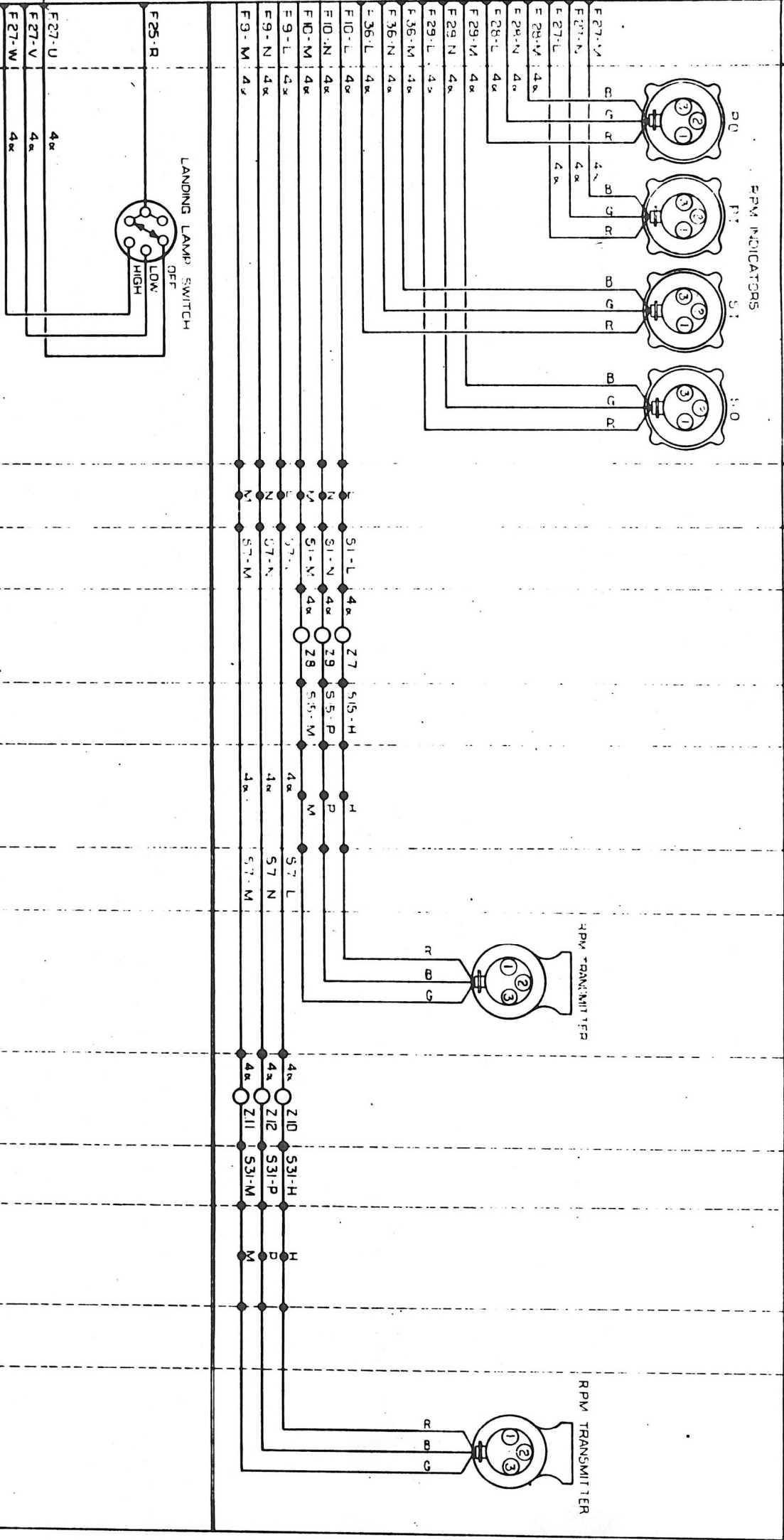

GENERAL SERVICES

FUEL PUMPS.

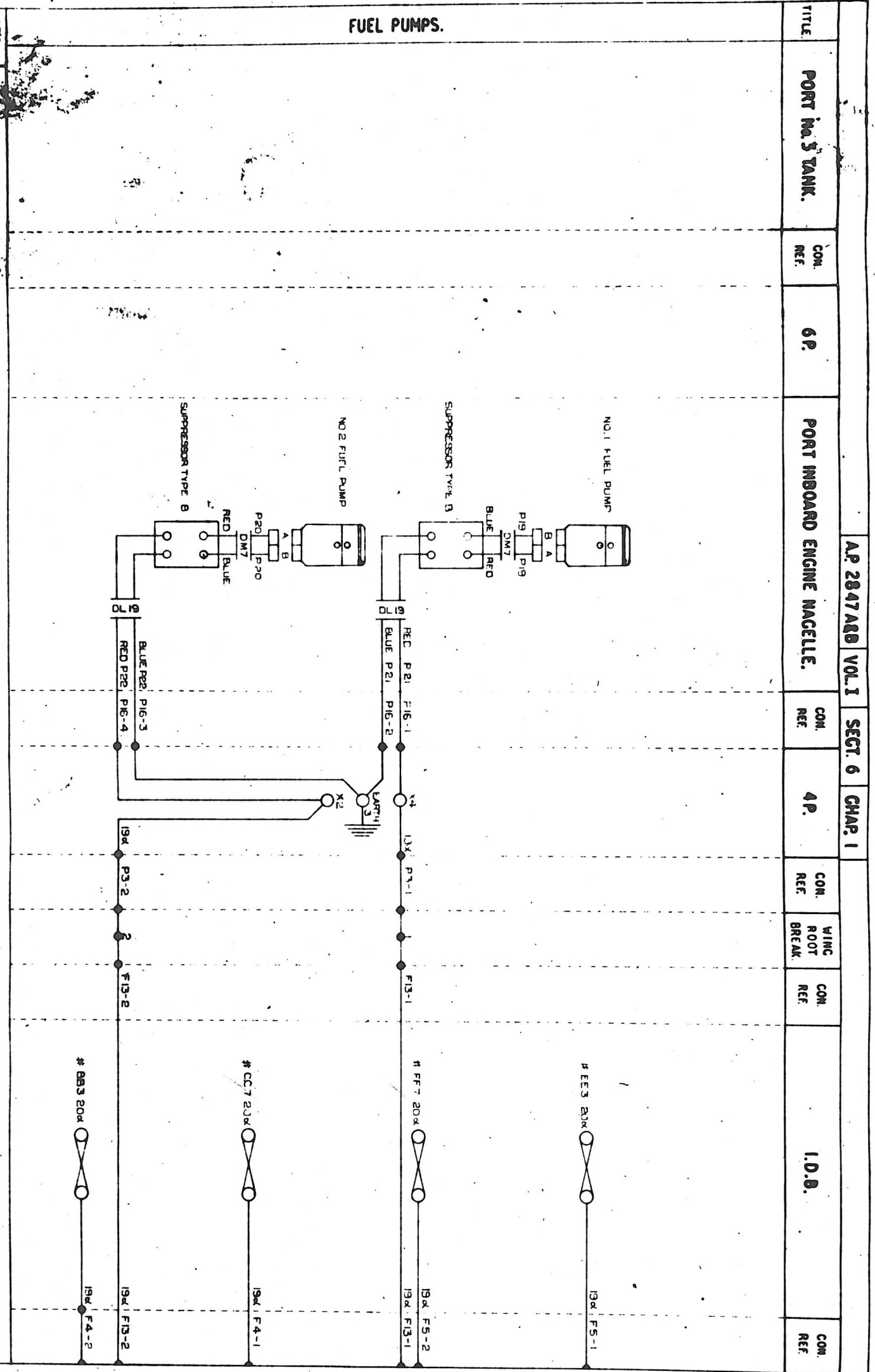

AP 2847 ARB VOL. I SECT. 6 CHAP. 1

TITLE	PORT No. 5 TANK.	COM. REF.	6 P.	PORT INBOARD ENGINE MAGELLE.	COM. REF.	4 P.	COM. REF.	WING ROOT BREAK.	COM. REF.	I.D.B.	COM. REF.

ROUTING CHART

AIR OBSERVER'S PANEL.		COM. REF.	WING ROOT BREAK.	COM. REF.	SP	COM. REF.	STARBOARD INBOARD ENGINE MACELE.	7P	COM. REF.	STARBOARD NO.3 TANK
-----------------------	--	-----------	------------------	-----------	----	-----------	----------------------------------	----	-----------	---------------------

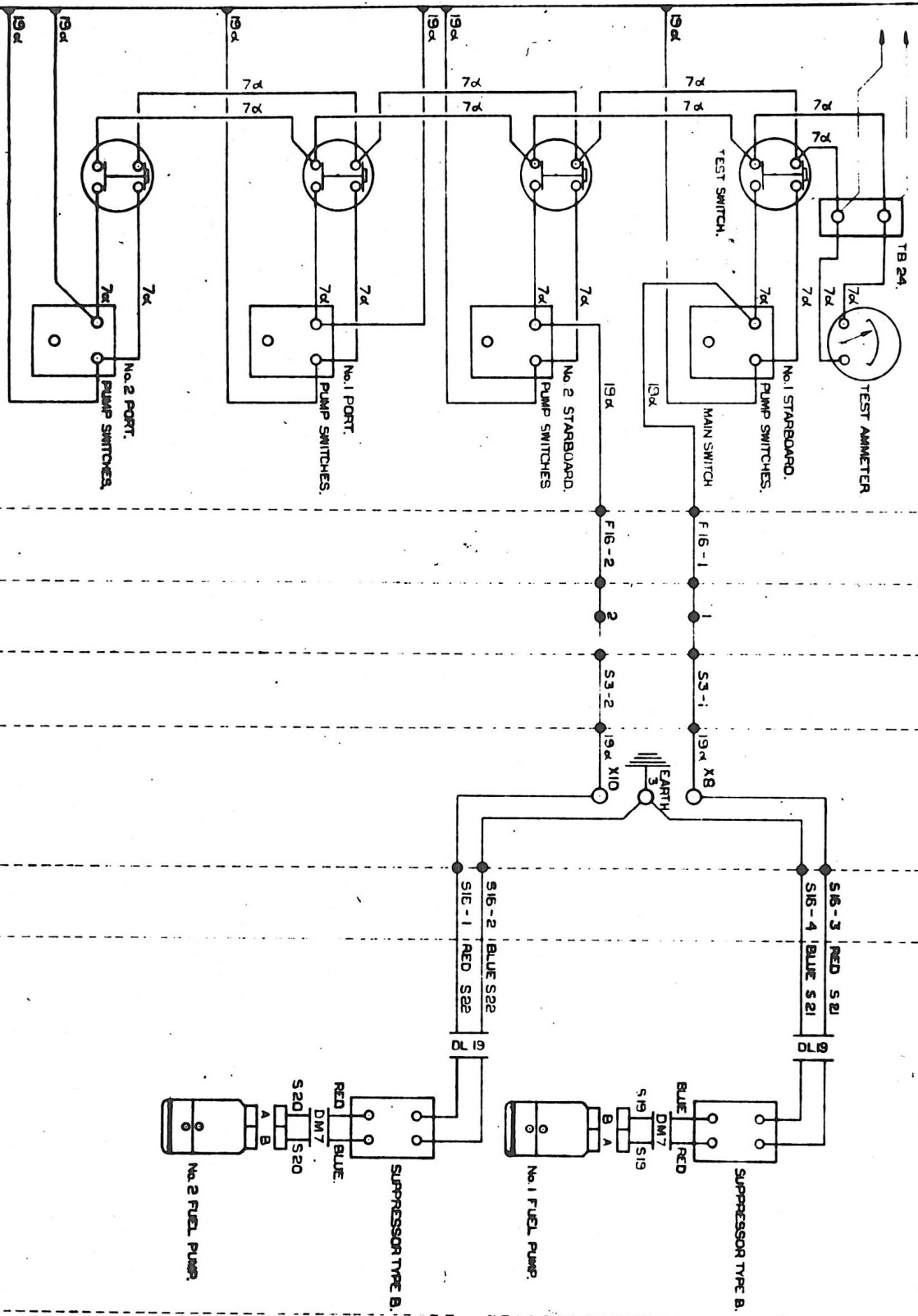

GENERAL SERVICES

FUEL CONTENTS GAUGES.

A.P.2847A8B VOL. I SECT. 6 CHAP. I

TITLE	PORT No. 3 TANK.	COM. REF.	6P	PORT INBOARD ENGINE NACELLE.	COM. REF.	4P	COM. REF.	WING ROOT BREAK.	COM. REF.	I.D.B	COM. REF.

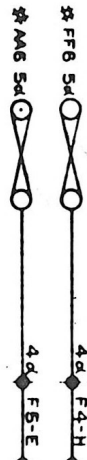
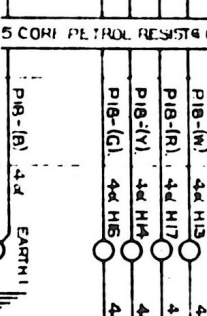
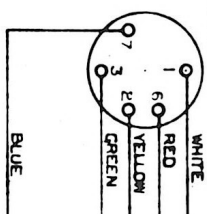
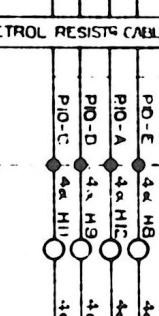
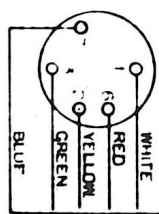
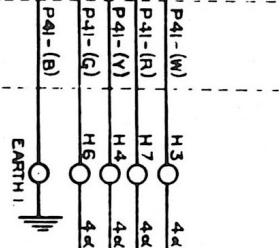
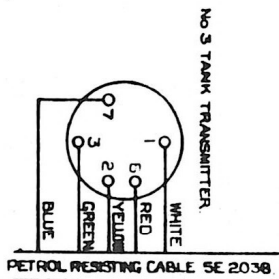

AIR OBSERVER'S PANEL.

A.P.2847A8B VOL. I SECT. 6 CHAP. I

STARBOARD INBOARD ENGINE MAGELLE.

7P.

STARBOARD No. 3 TANK.

CON. REF.	WIRC ROOT BREAK	CON. REF.	SP.	CON. REF.	7P.	CON. REF.

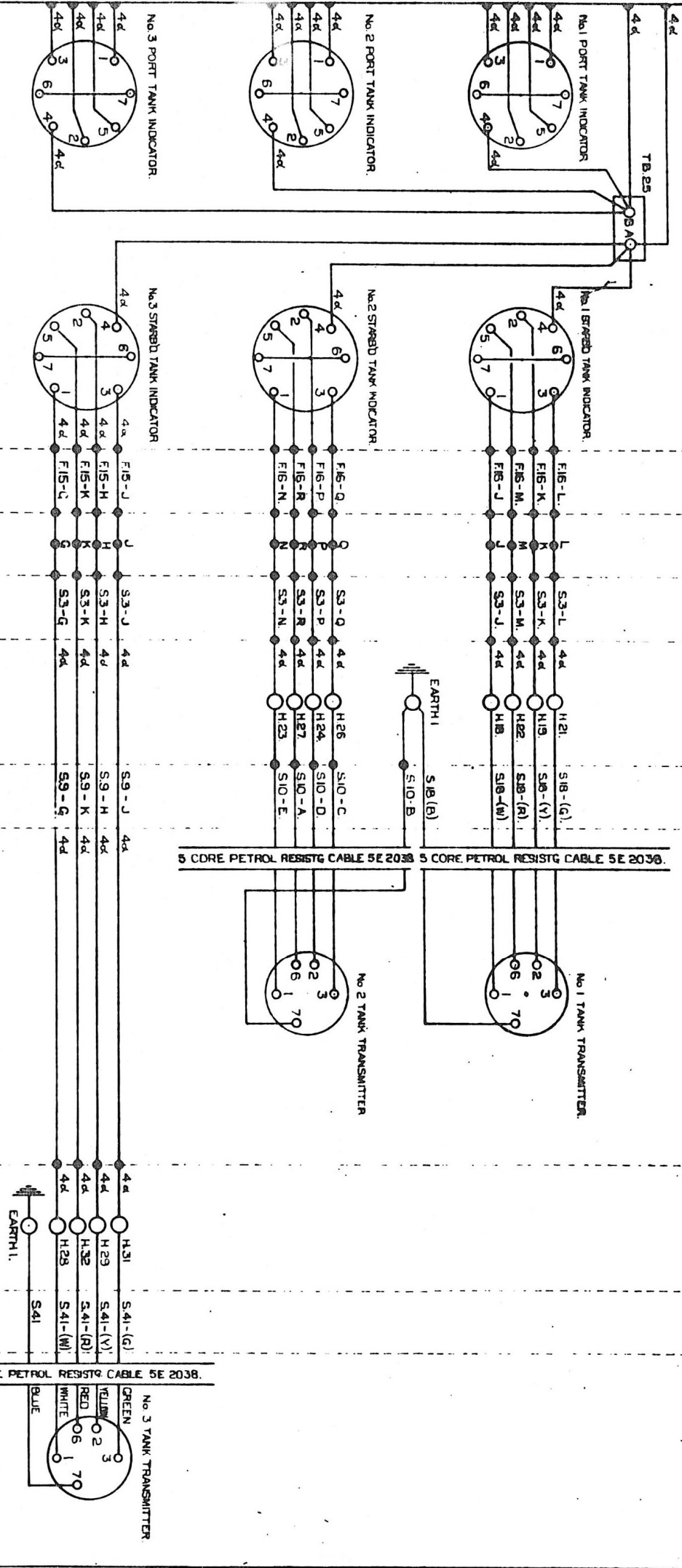

GENERAL SERVICES

TITLE	EQUIPMENT	CON. REF.	4 P	CON. REF.	WING ROOT BREAK	CON. REF.	1 D B	CON. REF.	2 D B	CON. REF.	PILOT'S PANEL
UNDERCARRIAGE INDICATORS (U)	PORT INBOARD ENGINE NACELLE UP SWITCHES R.H. UP SWITCHES L.H. DOWN SWITCHES R.H. DOWN SWITCHES L.H.										

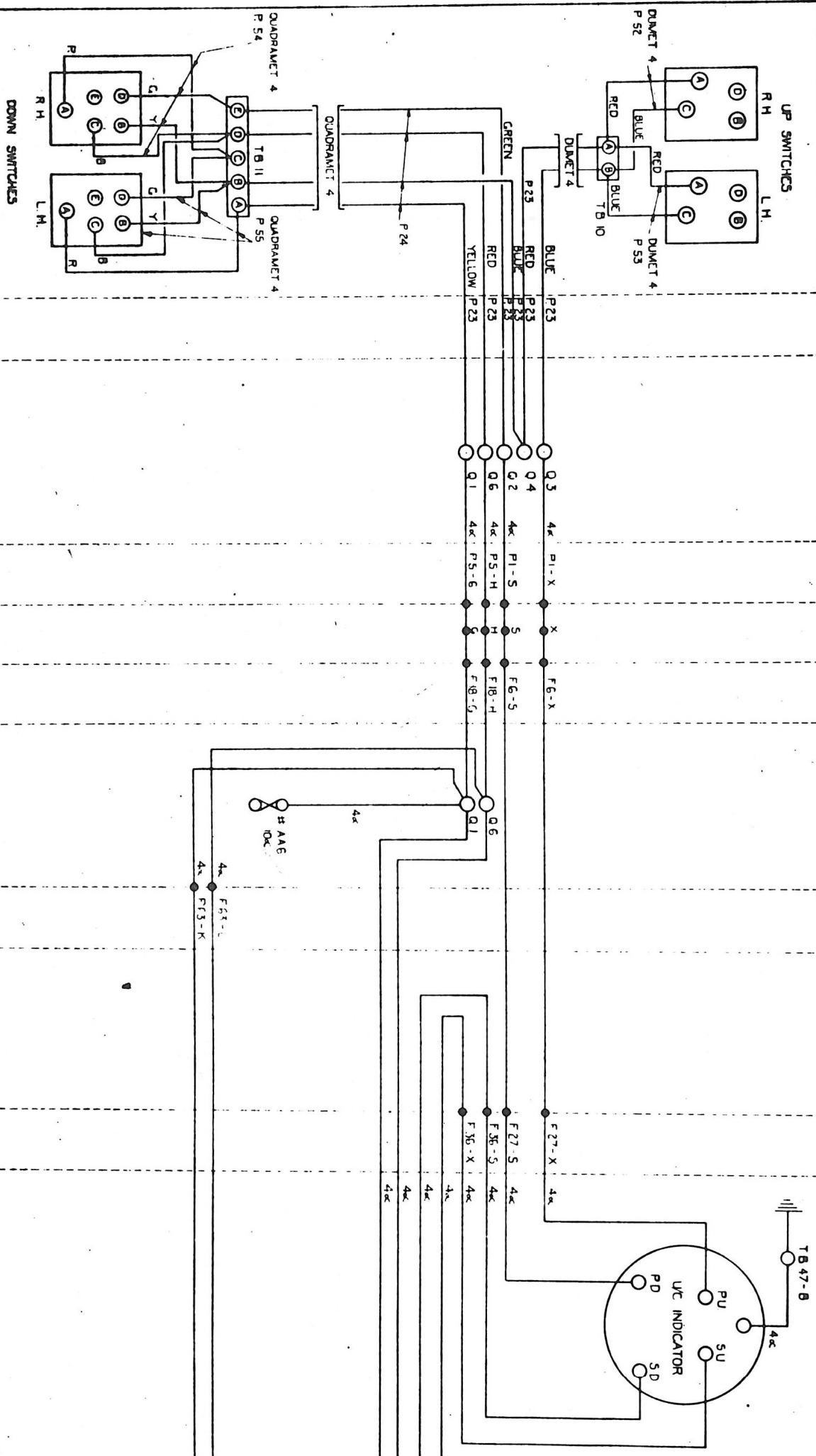

UNDERCARRIAGE INDICATORS (U)

COM. REF.	NAVIGATOR'S PANEL	COM. REF.	EQUIPMENT	COM. REF.	WING ROOT BREAK	COM. REF.	S P	COM. REF.	EQUIPMENT STANDARD INBOARD ENGINE NACELLE
-----------	-------------------	-----------	-----------	-----------	-----------------	-----------	-----	-----------	---

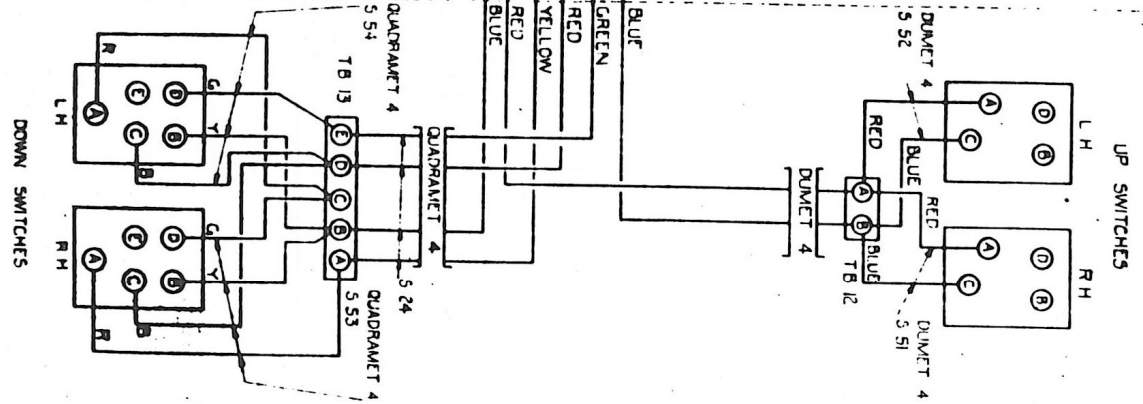
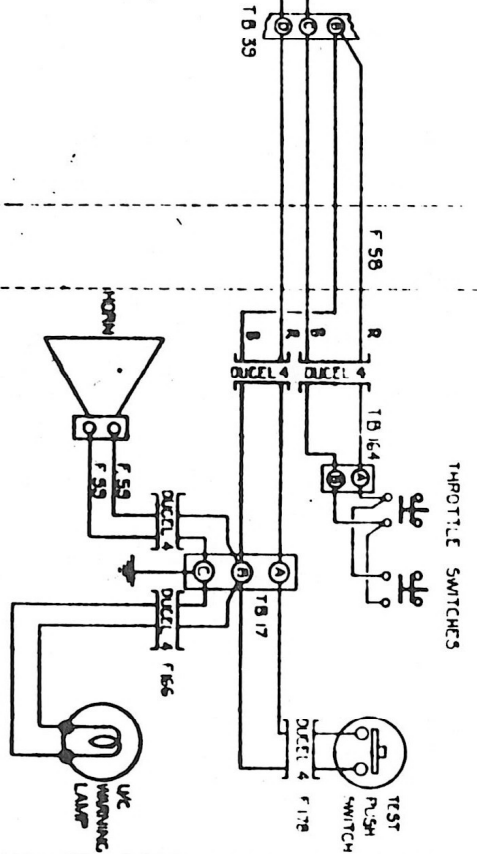
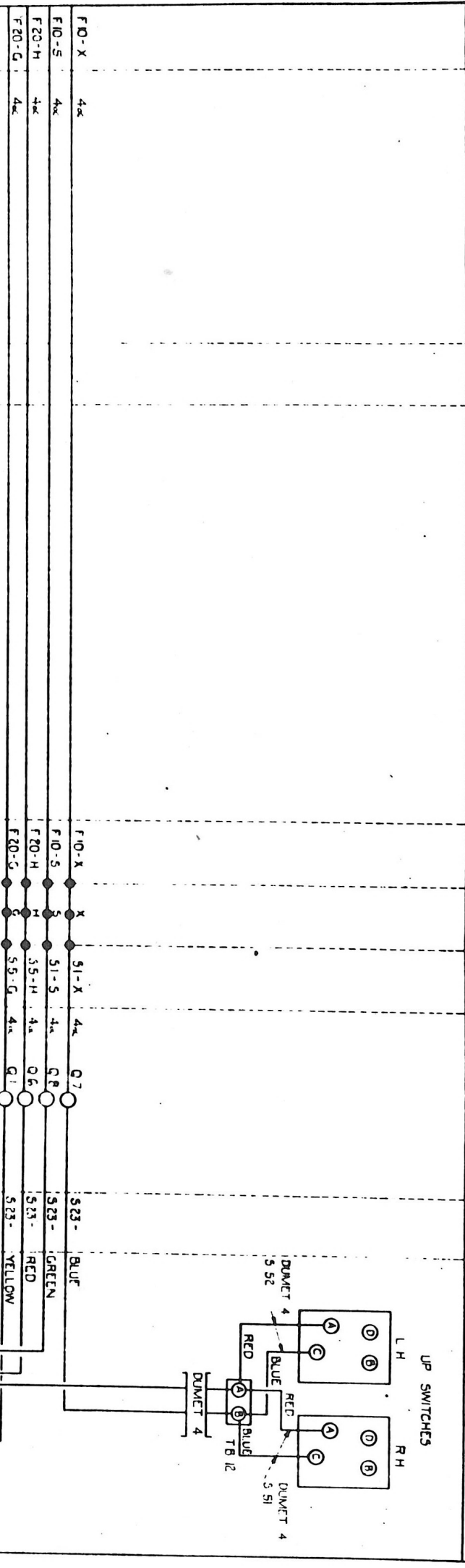

GENERAL SERVICES

TITLE	PORT WING TIP LAMPS	CON. REF.	6 P	CON. REF.	4 P	CON. REF.	CON. REF.	WING ROOT BREAK	CON. REF.	1 DB	CON. REF.	2 DB	CON. REF.	PILOT'S PANEL	BOMB AIMER'S PANEL
-------	---------------------	-----------	-----	-----------	-----	-----------	-----------	-----------------	-----------	------	-----------	------	-----------	---------------	--------------------

NAVIGATION, RECOGNITION & IDENTIFICATION LAMPS

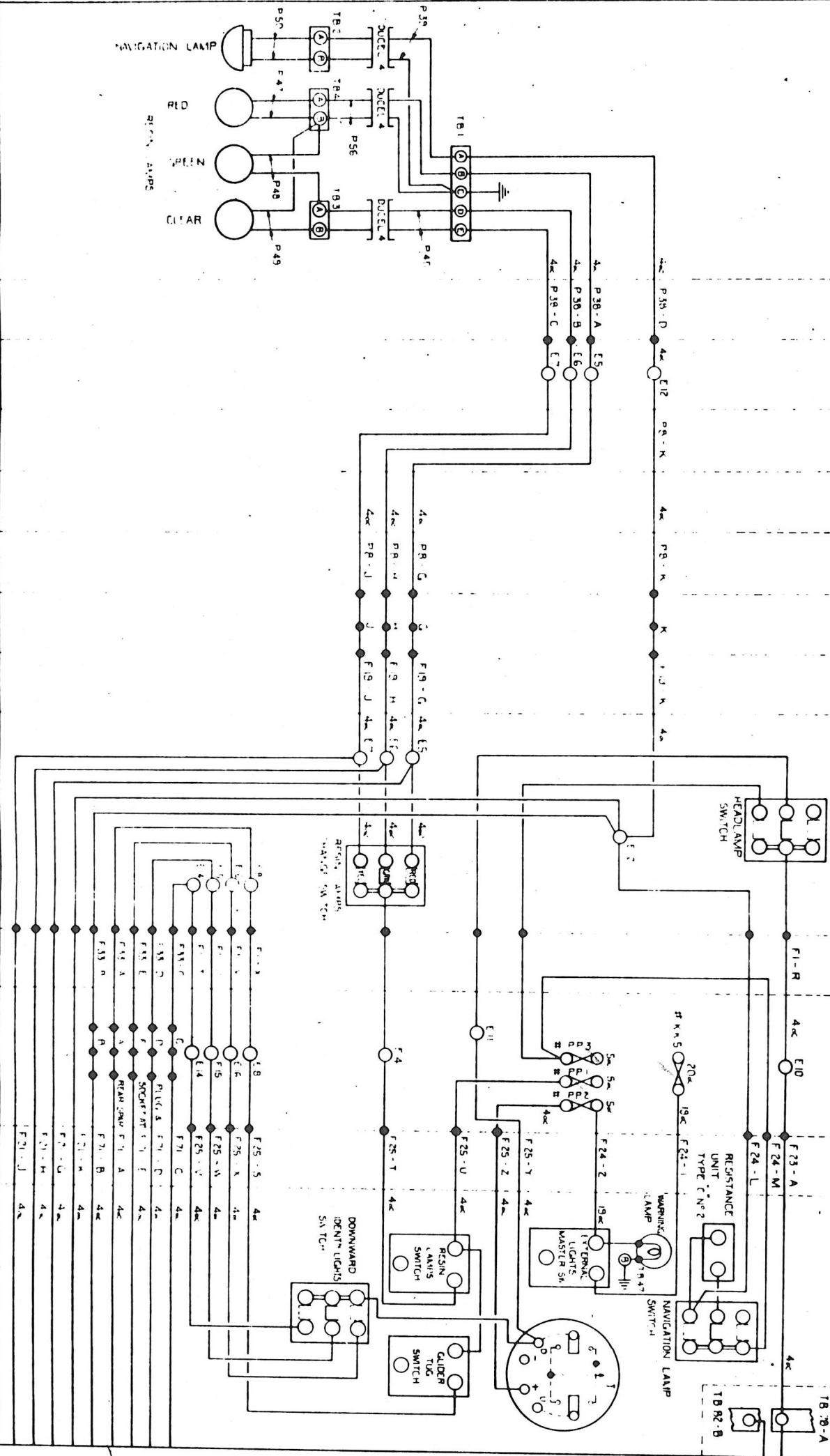

30B	COM. REF.	EQUIPMENT	8P	COM. REF.	EQUIPMENT	WING ROOT BRACK	COM. REF.	5P	COM. REF.	7P	COM. REF.	STBD WING TIP LIGHTS
-----	-----------	-----------	----	-----------	-----------	-----------------	-----------	----	-----------	----	-----------	----------------------

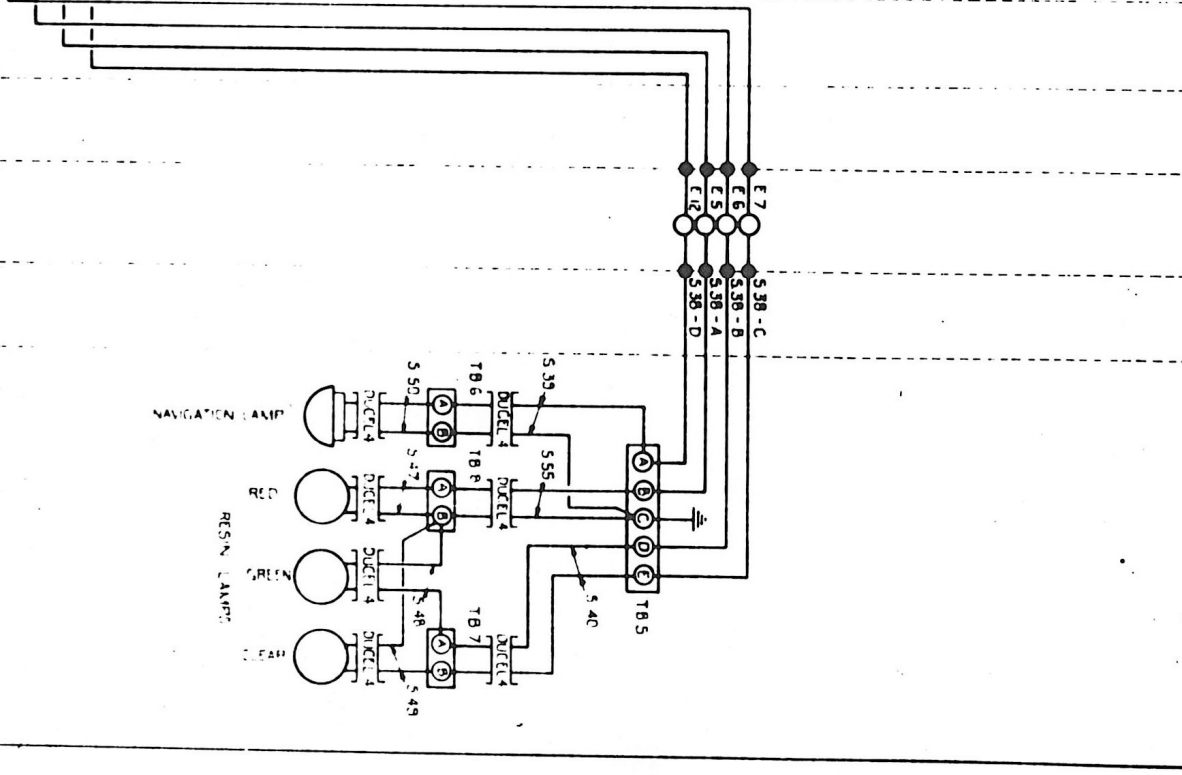
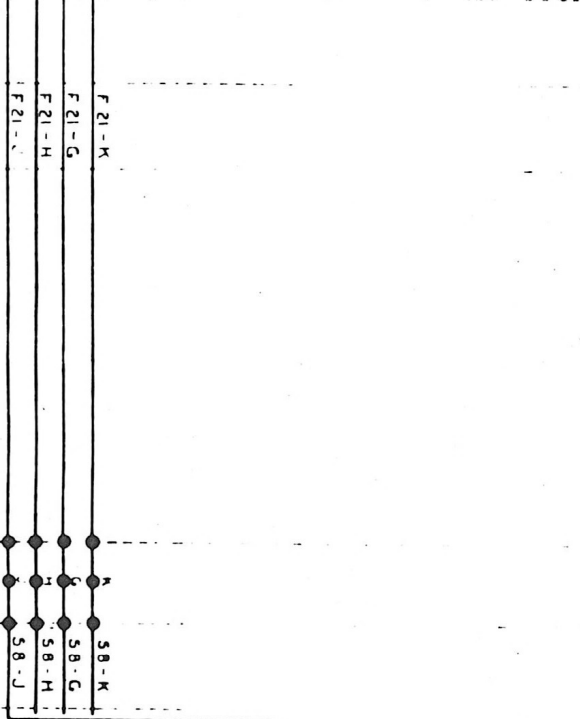
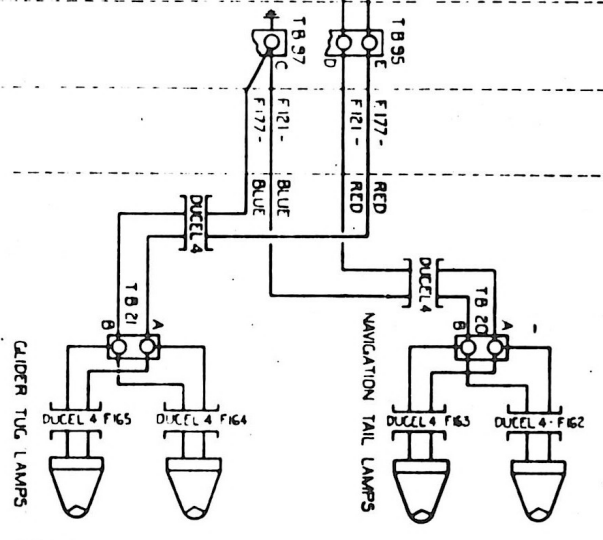
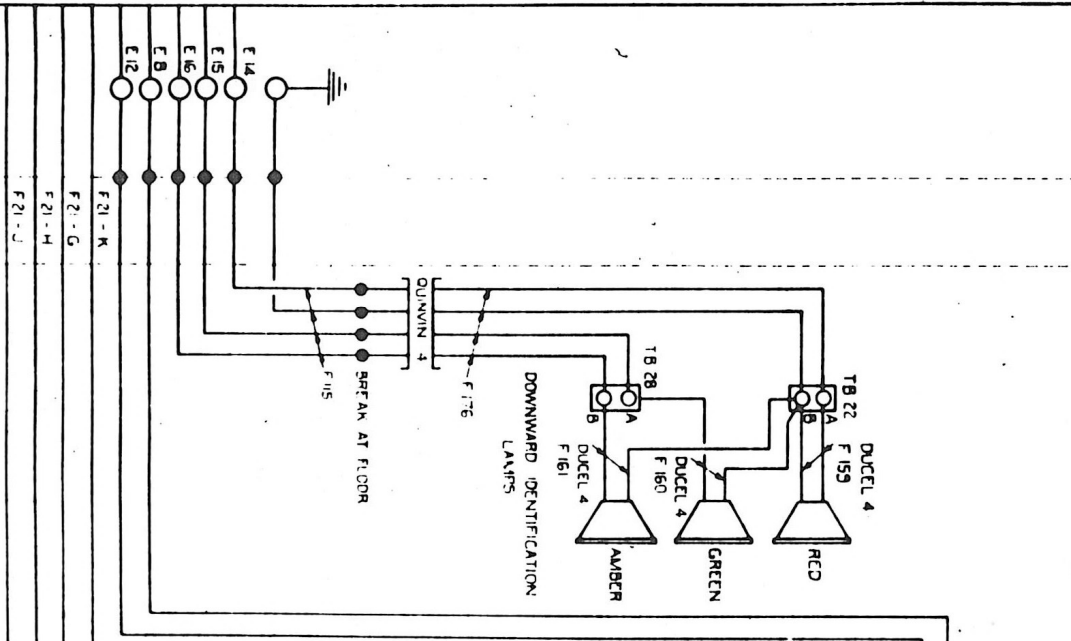
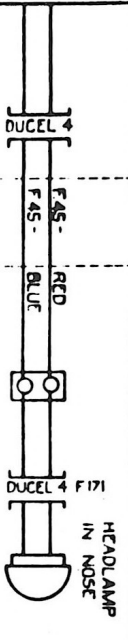

GENERAL SERVICES

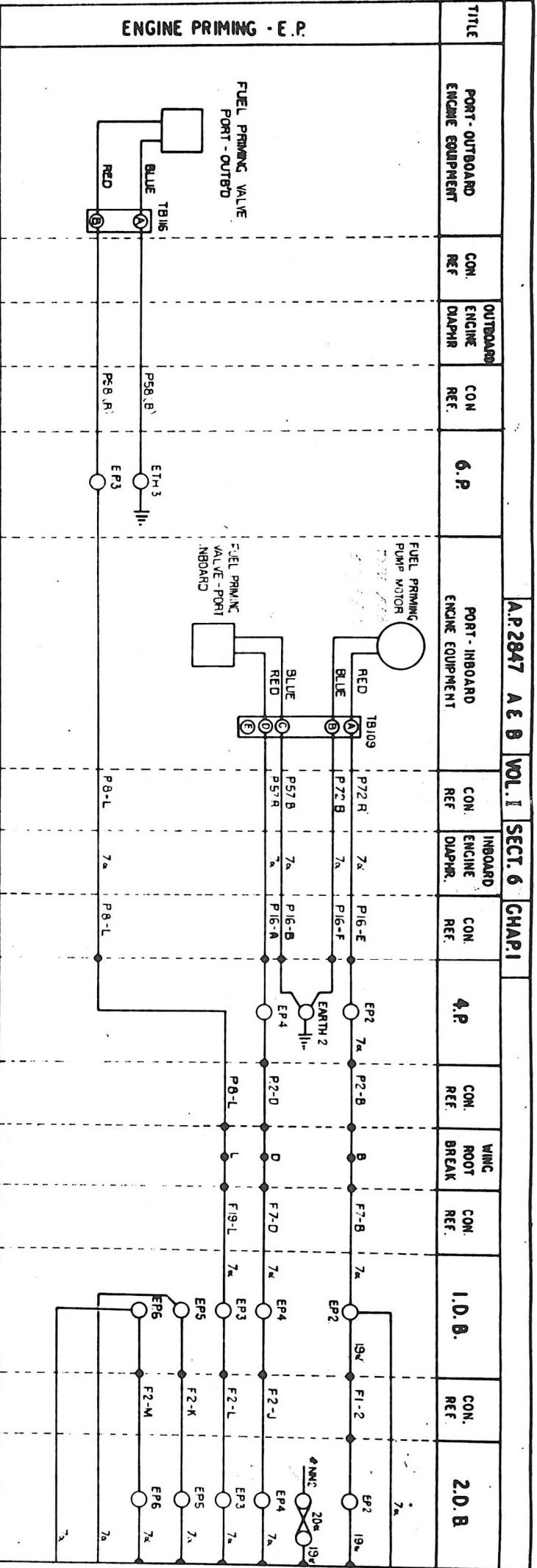

ENGINE PRIMING - E.P.

A.P.2847 A & B VOL. I SECT. 6 CHAP. I

TITLE	PORT - OUTBOARD ENGINE EQUIPMENT	CON. REF.	OUTBOARD ENGINE DIAPHR.	CON. REF.	G.P.	PORT - INBOARD ENGINE EQUIPMENT	CON. REF.	INBOARD ENGINE DIAPHR.	CON. REF.	A.P.	CON. REF.	WING ROOT BREAK	CON. REF.	I.D. B.	CON. REF.	2.0 B.

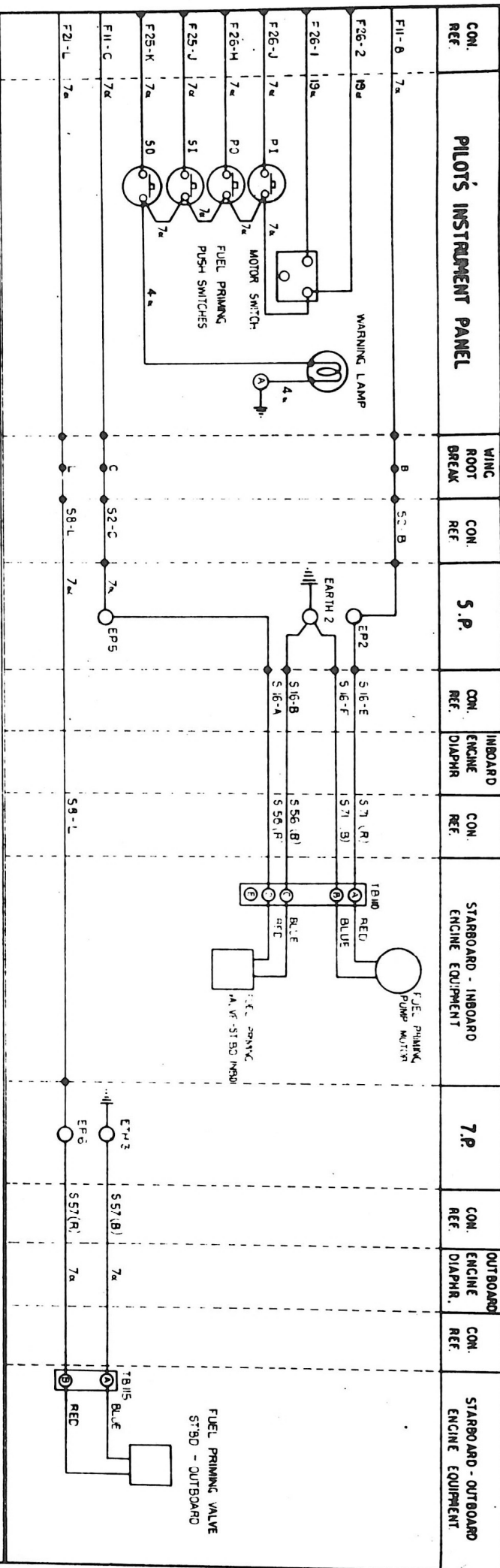

GENERAL SERVICES

TITLE	EQUIPMENT	CON. REF.	PANELS	CON. REF.	2 D.B.	CON. REF.	I D.B.	CON. REF.	REAR SPAN BREAK	CON. REF.	WING ROOT BREAK	CON. REF.	S.P.	CON. REF.	EQUIPMENT
HEATED PRESSURE HP - K	HEATED PRESSURE HP		OBSERVER'S PANEL CONTROL SW	F5-F F5-G											
DINGHY RELEASE - L	IMMERSION SWITCH		BOMB-AIMER'S PANEL #55420K	F23-G F2-B F11-M F11-M M S2-M L2 S43-A S42-A S43-B S42-B											BULKHEAD PLUG & SOCKET SOCKET FOR DINGHY OPERATING HEAD
FLAP INDICATOR - J	FLAP INDICATOR		PILOT'S PANEL FLAP INDICATOR	F2-F F2-G F2-H F3-A F3-B F3-C F3-D F3-E F70-A F70-B F70-C F70-D F70-E F85-A F85-B F85-C F85-D F85-E F89-A F89-B F89-C F89-D F89-E											PLUG & SOCKET BREAK-TRAILING EDGE FLAP TRANSMITTER IN PORT WING
BOMB FUSING & RELEASE SUPPLY - T	BOMB DOOR SW		BOMB-AIMER'S PANEL (STRB)	F41 F52 F57											

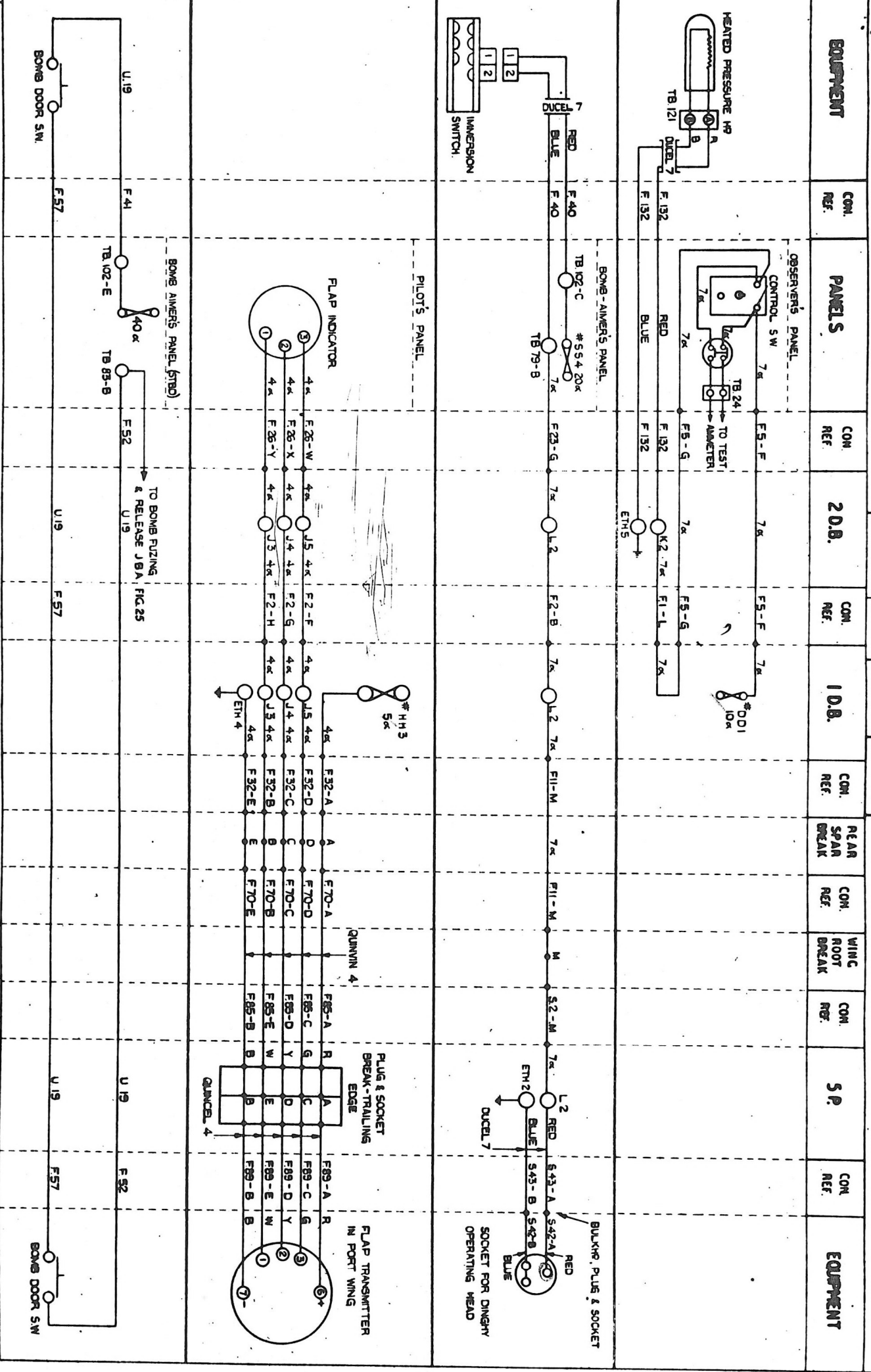

AP 2847 A.B.	VOL. I.	SECT. 6	CHAP. I
TITLE	IDB	CON. REF.	OBSERVER'S PANEL
		CON. REF.	
		CON. REF.	
		FLOOR BREAK	
		CON. REF.	
		EQUIPMENT	

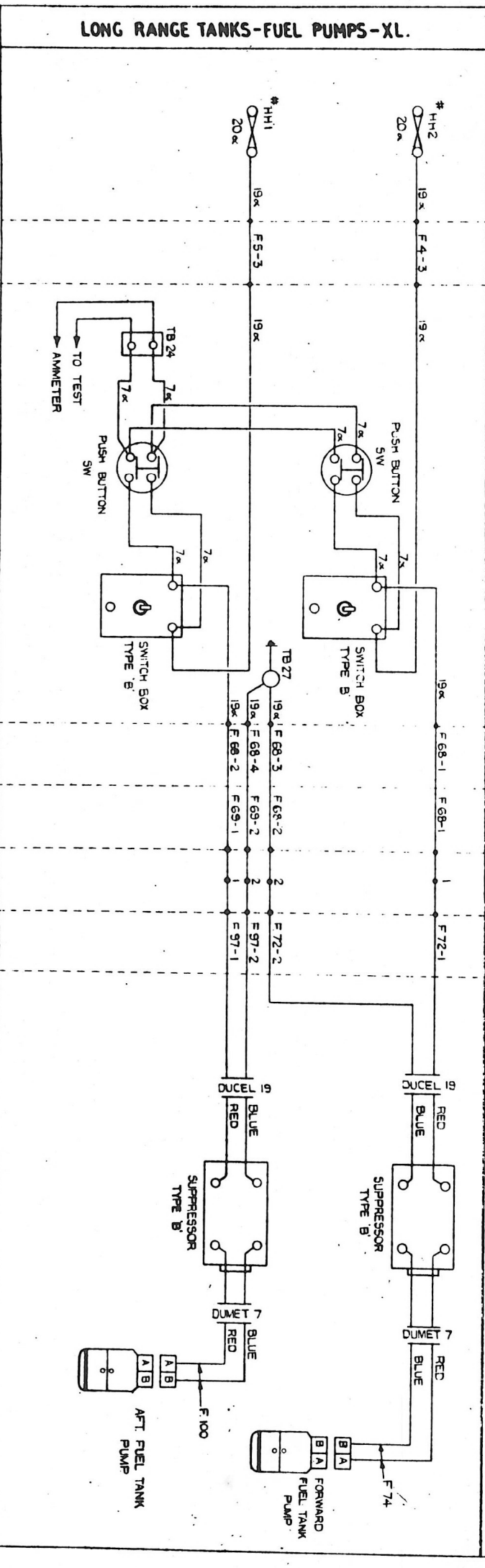
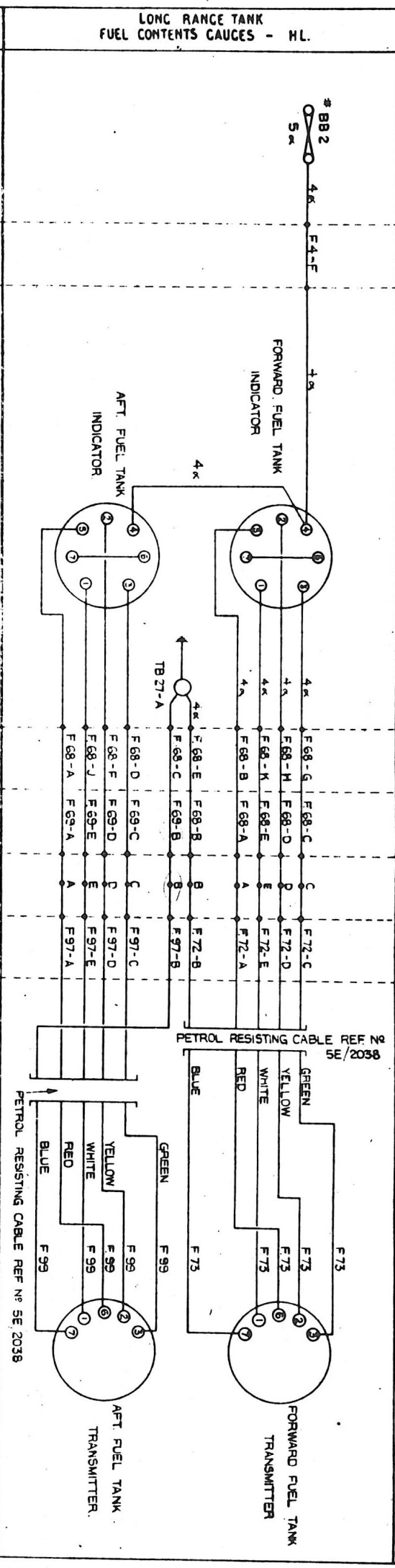

FIG 20

ROUTING CHART - GENERAL SERVICES.

FIG 20

STUD. BOARD AMER'S PANEL	COM REF	2DB	COM REF	IDB	COM REF	3P	COM REF	3DB
--------------------------	---------	-----	---------	-----	---------	----	---------	-----

RADIAL FEEDER DISTRIBUTION

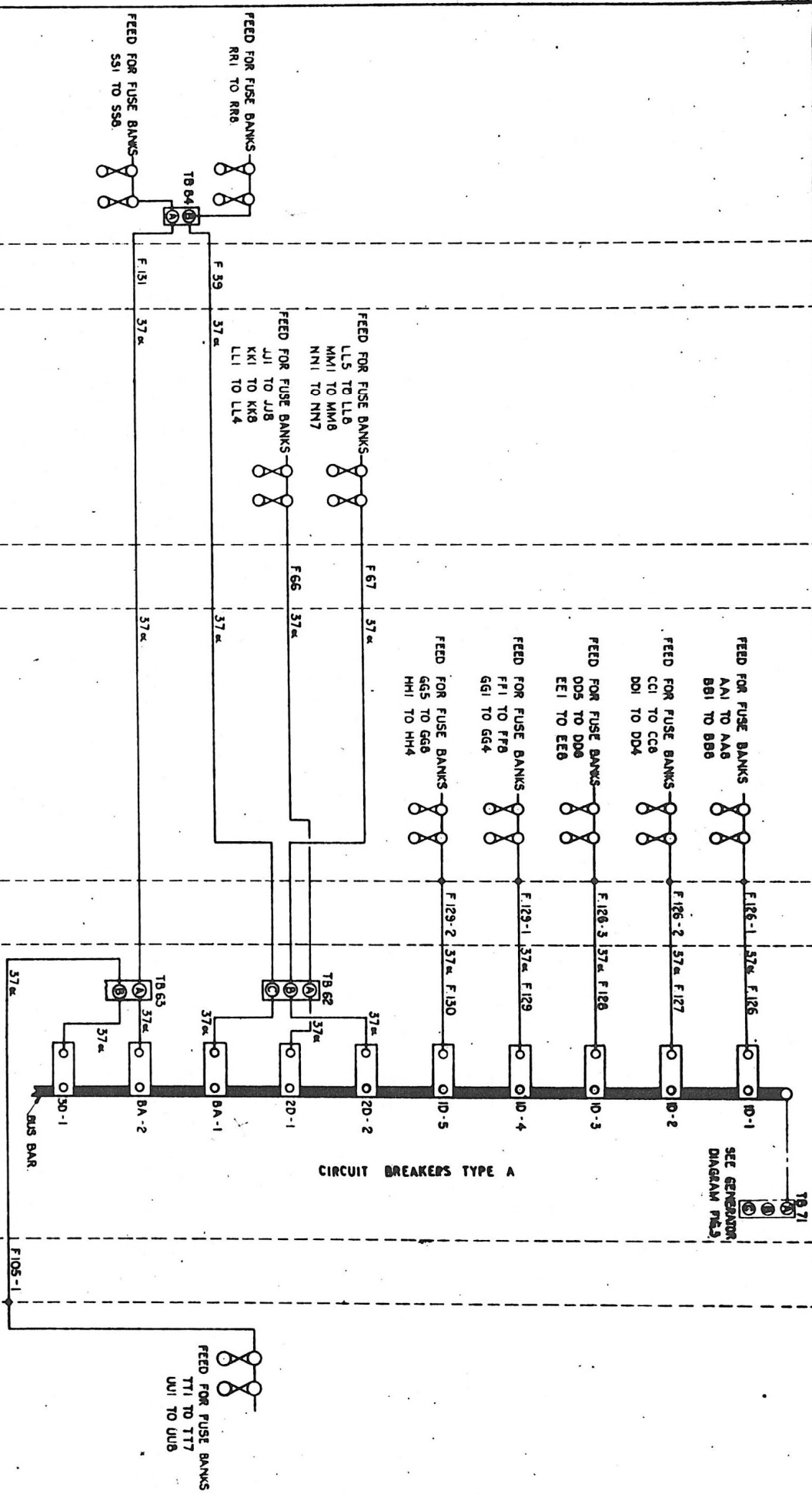

ROUTING CHART - GENERAL SERVICES

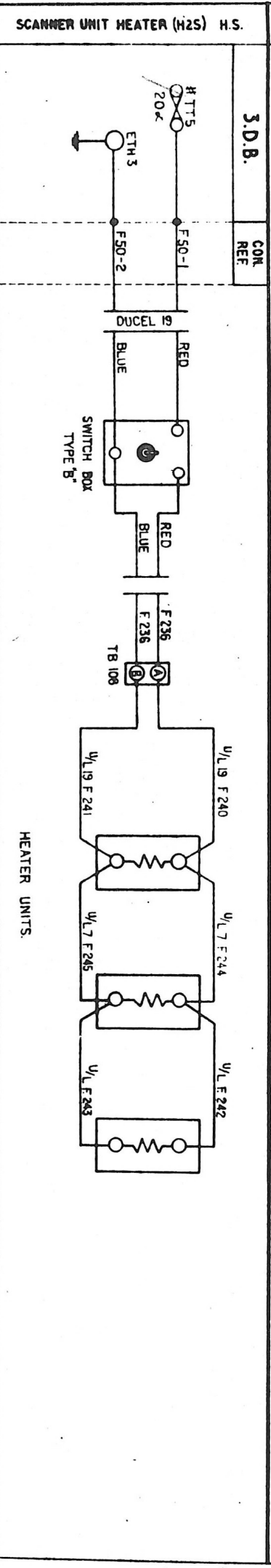
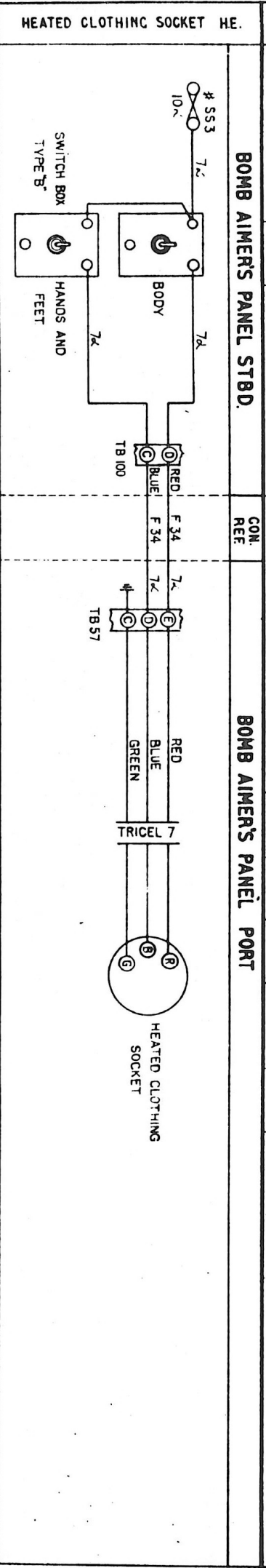
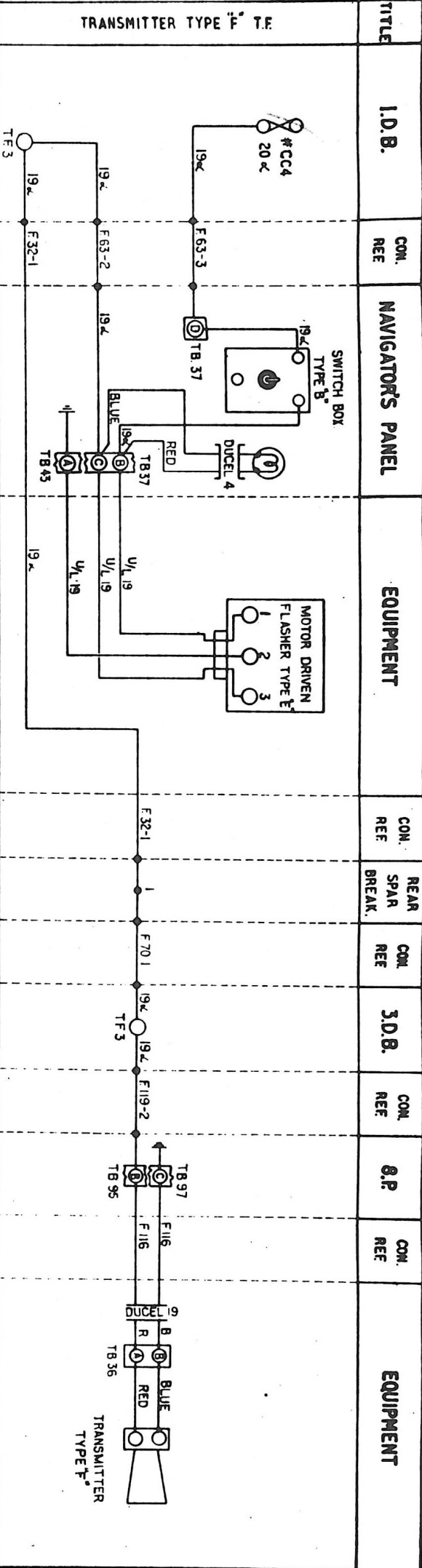



REAR SPAN BREAK	COM. REF.	3.D.B.	COM. REF.	MID TURRETS	COM. REF.	8. P.	COM. REF.	EQUIPMENT
-----------------	-----------	--------	-----------	-------------	-----------	-------	-----------	-----------

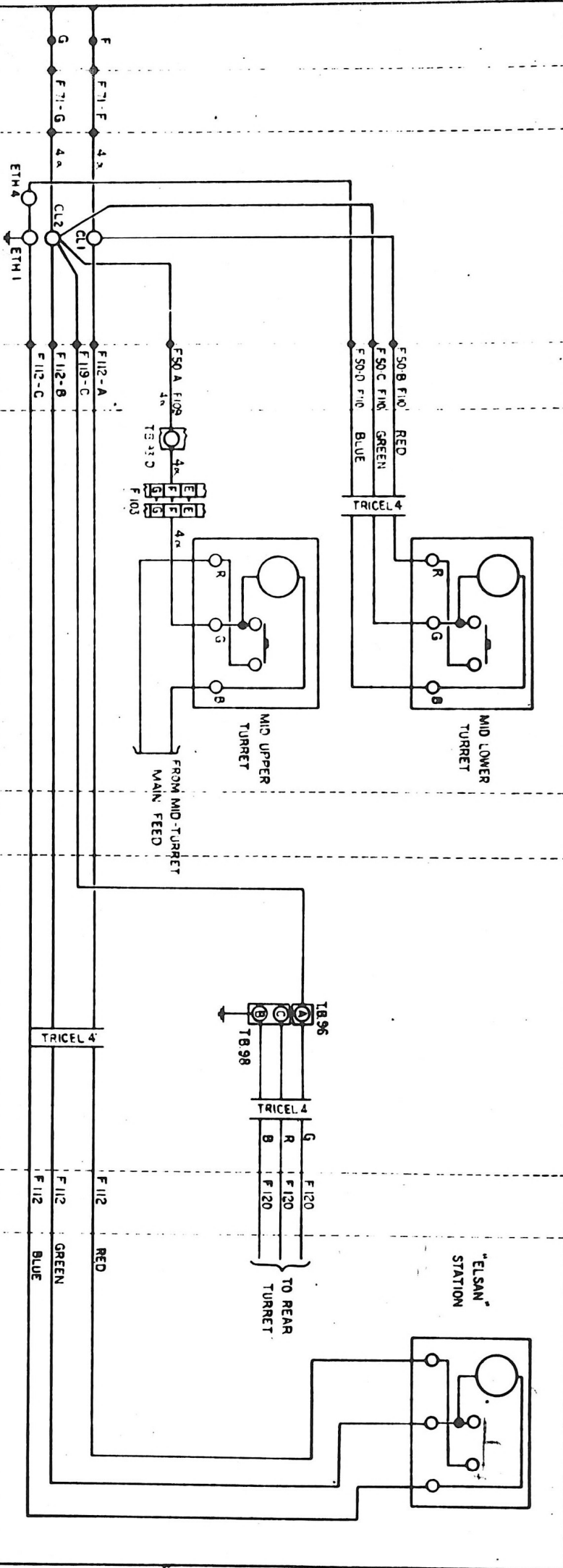

GENERAL SERVICES

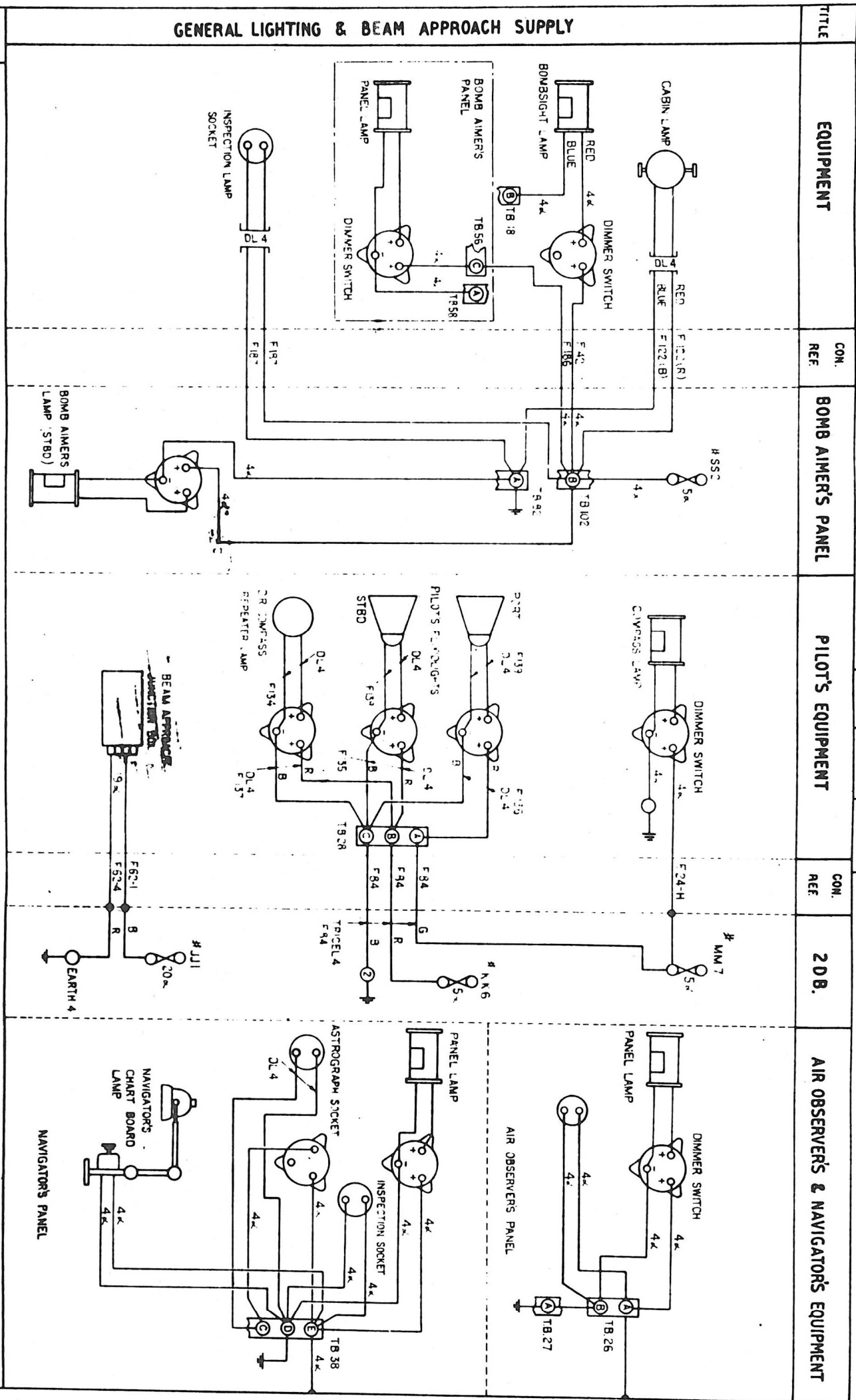
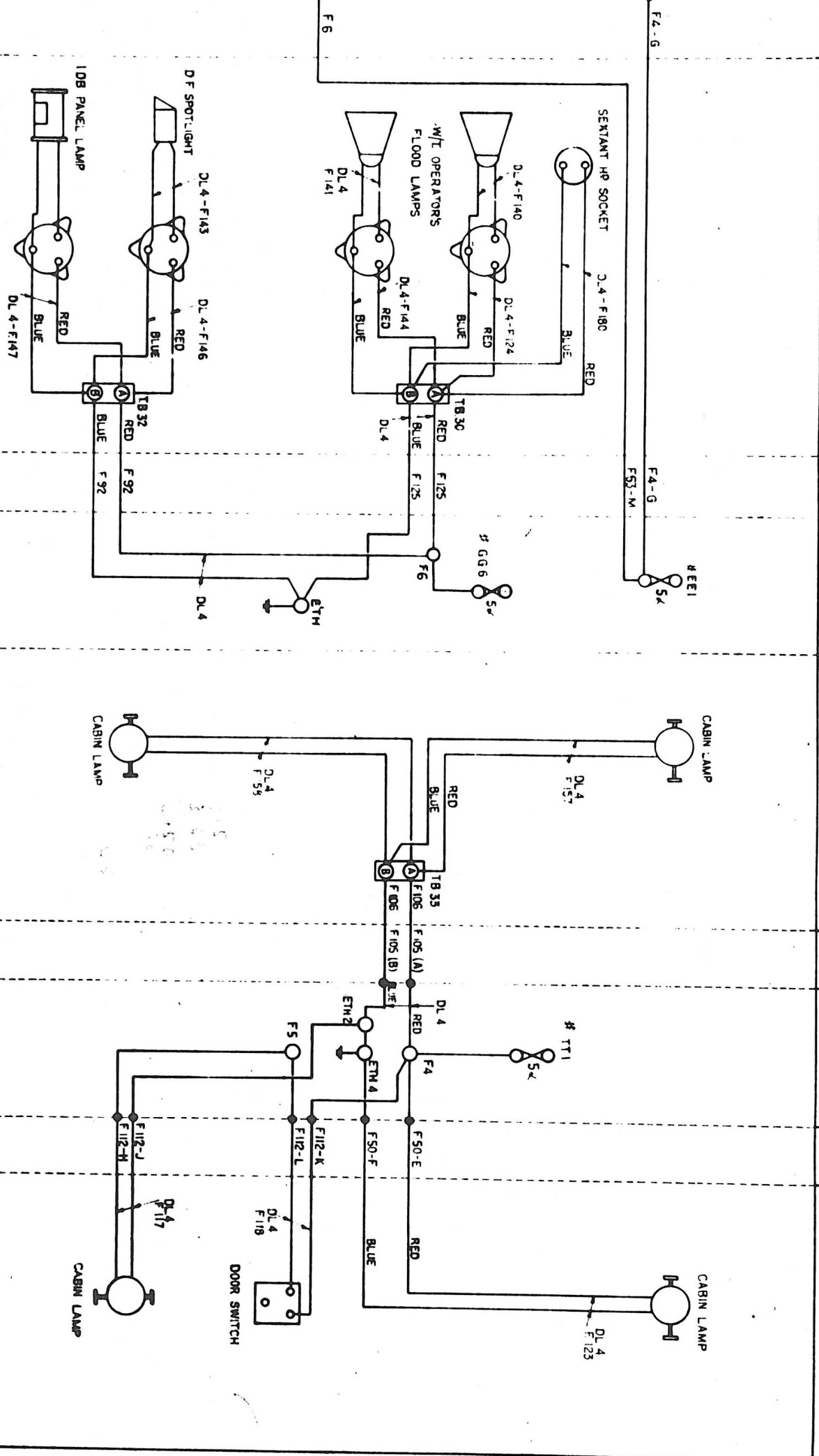

FIG 24

ROUTING CHART

COM. REF.	W/T OBSERVER'S EQUIPMENT	COM. REF.	I. D. B.	EQUIPMENT	COM. REF.	3 D. B.	COM. REF.	EQUIPMENT



GENERAL SERVICES

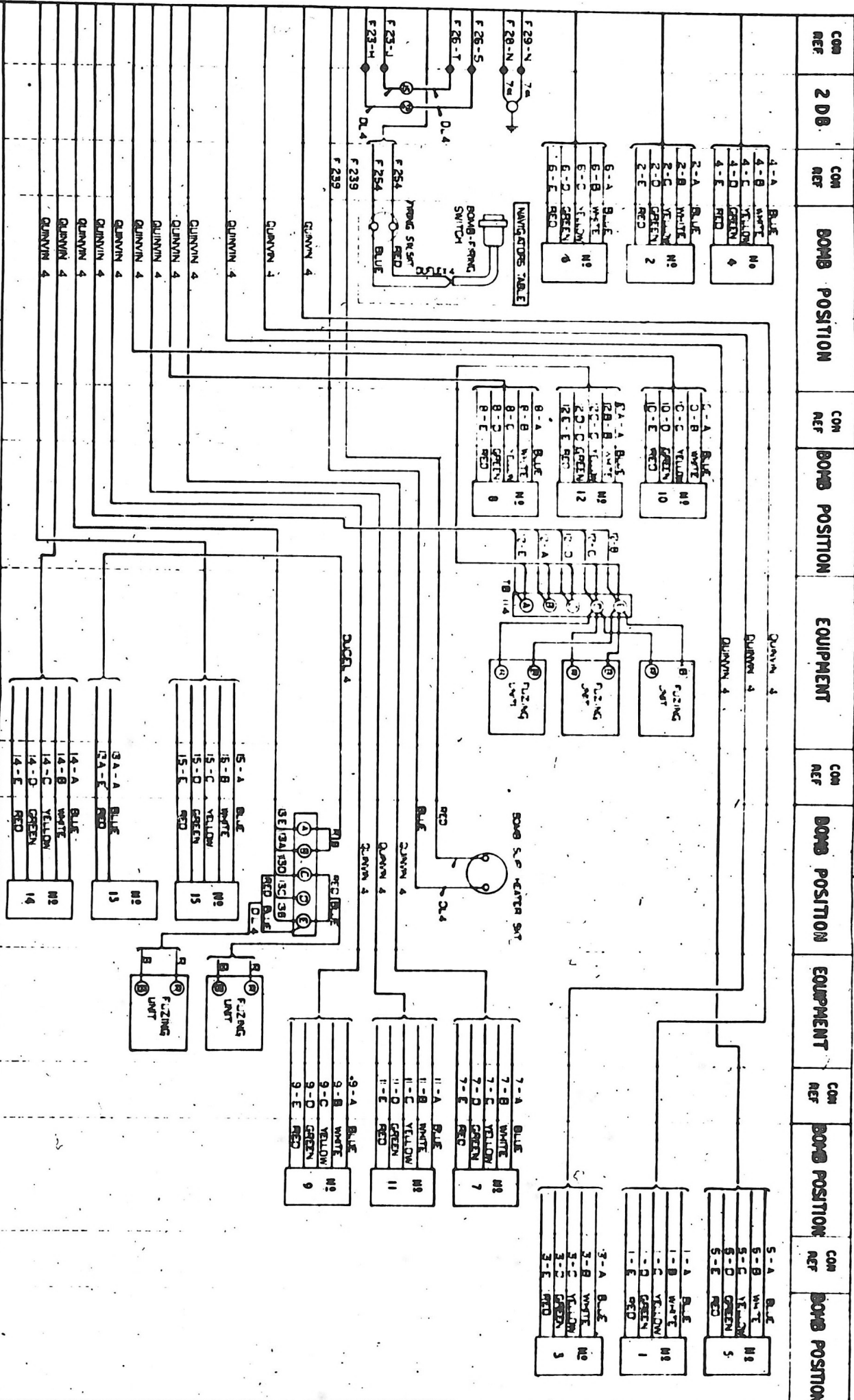

GENERAL SERVICES

TRUC	EQUIPMENT	BOMB AIMERS PANEL PORT	COM REV	BOMB AIMERS PANEL STANDARD	COM REV	FLARE CHUTE - FORWARD
------	-----------	------------------------	---------	----------------------------	---------	-----------------------

FLARE CHUTE MK V (F C)

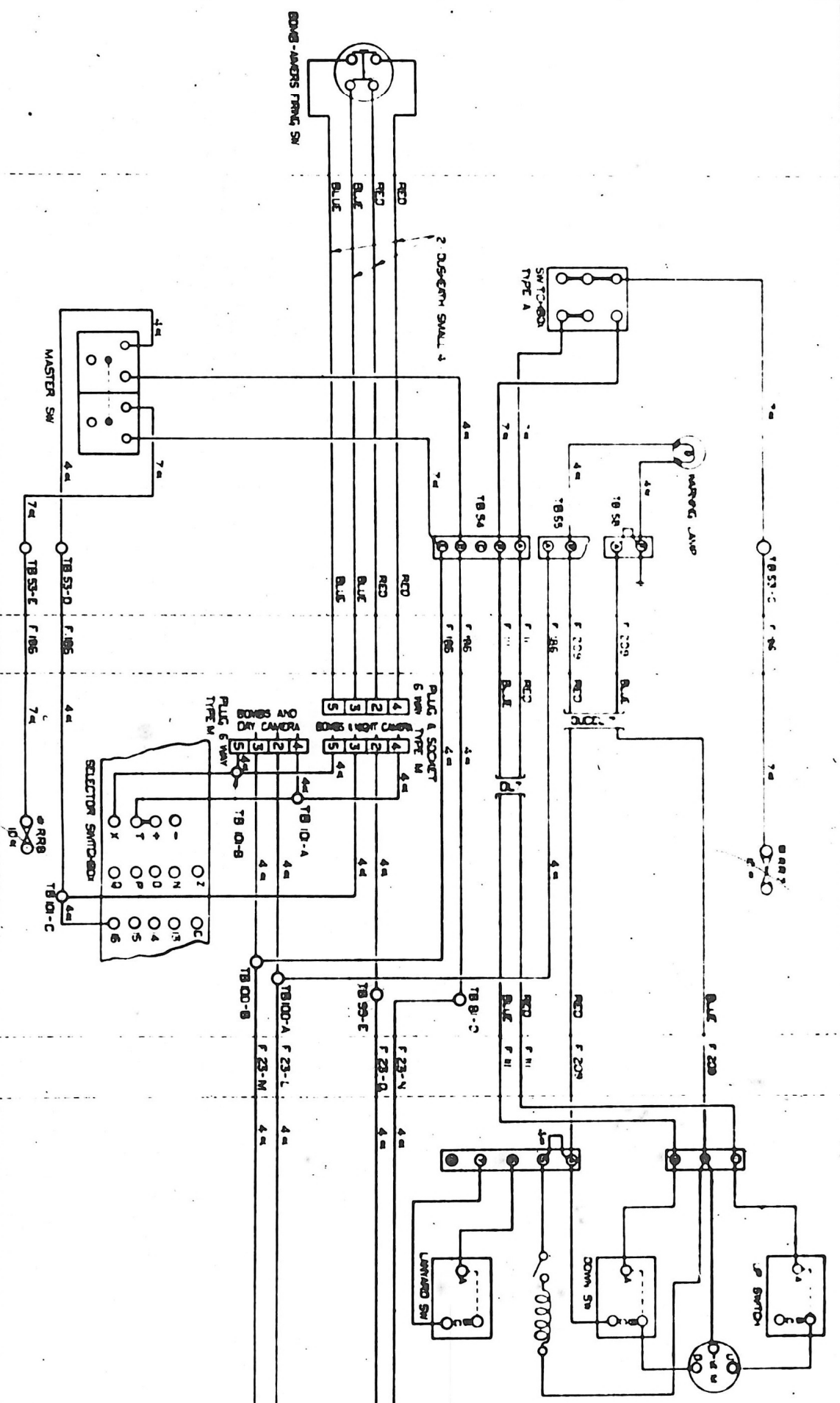

COM REF	2 DB	COM REF	EQUIPMENT	IDB	COM REF	SECT. 6	COM REF	3 DB	COM REF	FLARE CHUTE - ACT
				AP. 2847 A&B VOL. I		CHAP. 1				

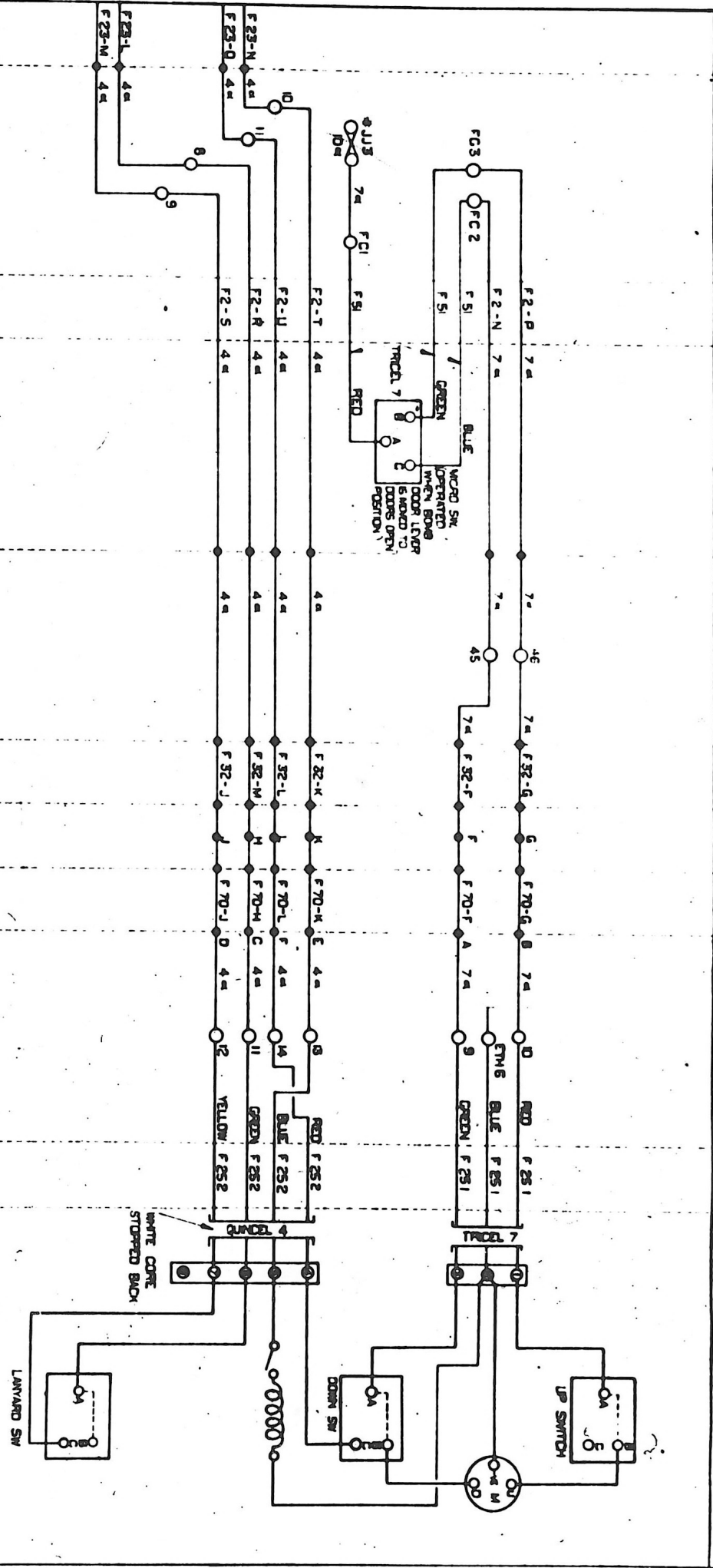

# GENERAL SERVICES

ALL TURRET SUPPLIES & INTERNAL DISTRIBUTION

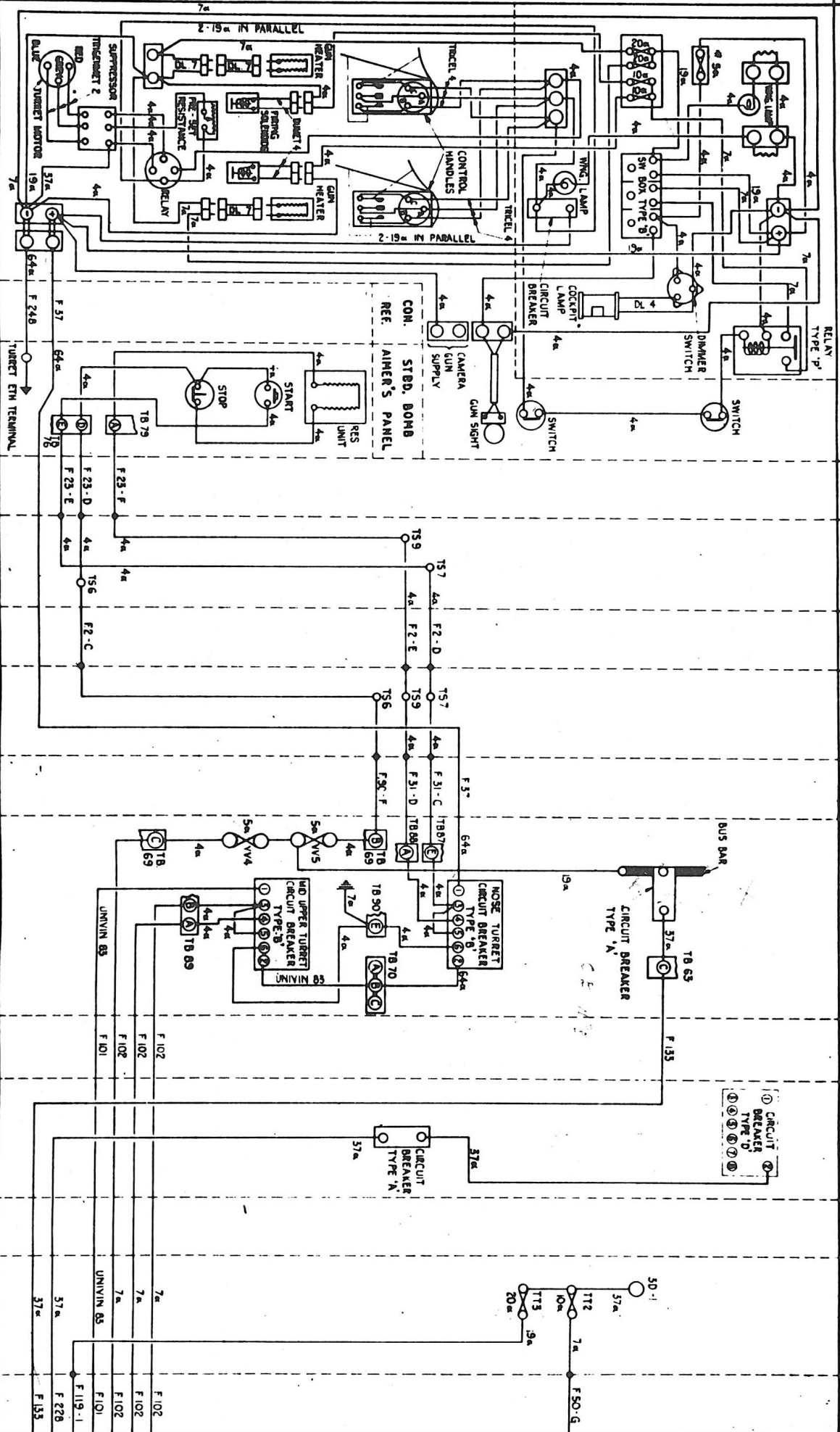

TITLE		A.P. 2847 A & B VOL. I SECT. 6 CHAP. I										
FRONT TURRET		CON. REF.	2DB	CON. REF.	IDB	CON. REF.	3P	CON. REF.	2P	CON. REF.	3DB	CON. REF.

ROUTING CHART

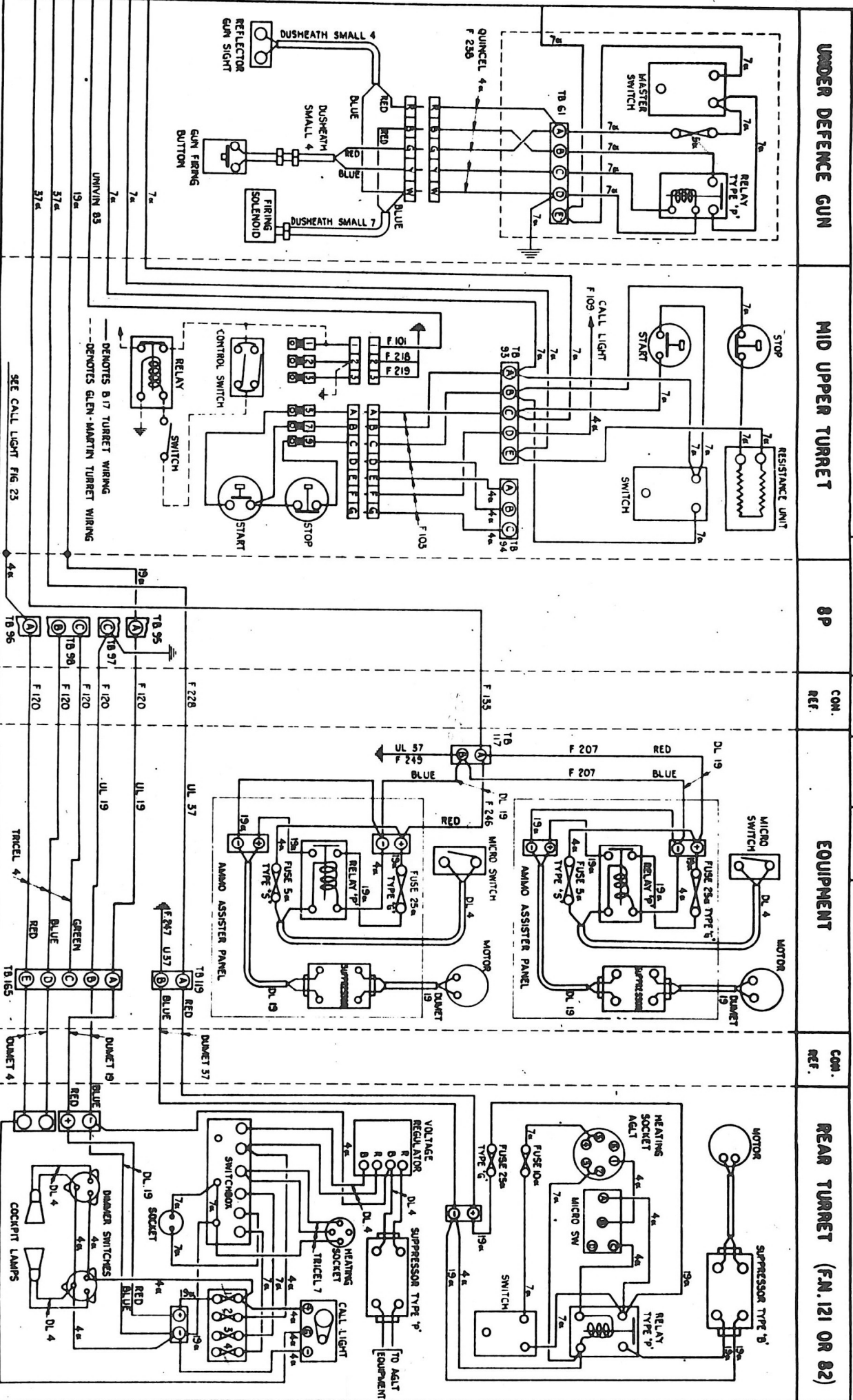

GENERAL SERVICES

TITLE	EQUIPMENT	CON. REF.	BOMB AIMERS' PANEL STARBOARD	EQUIPMENT	CON. REF.	PILOT'S PANEL	CON. REF.	2 D.B.	CON. REF.	1 D.B.
AUTO BOMB SIGHT-I AND AUTO CONTROLS-S.										
L.T. & H.T. SUPPLY - D.										

TITLE		AP 2847 A E B		VOL. I SECT. 6 CHAP. 1			
EQUIPMENT		COM. REF.	BOMB AIRMEN'S PANEL STARBOARD	COM. REF.	2.0.0.	COM. REF.	EQUIPMENT

CAMERA SUPPLY & HEATING - P

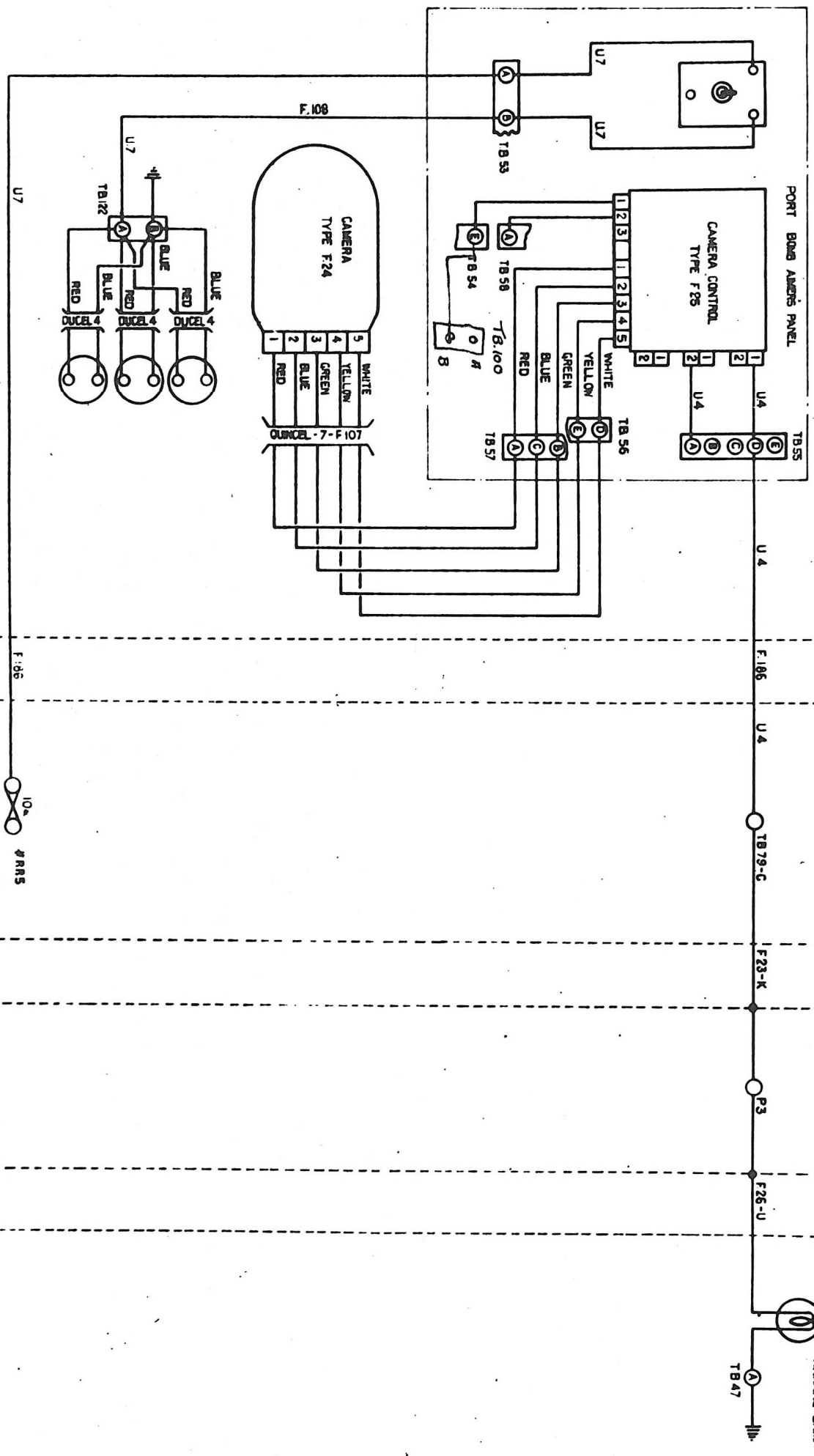
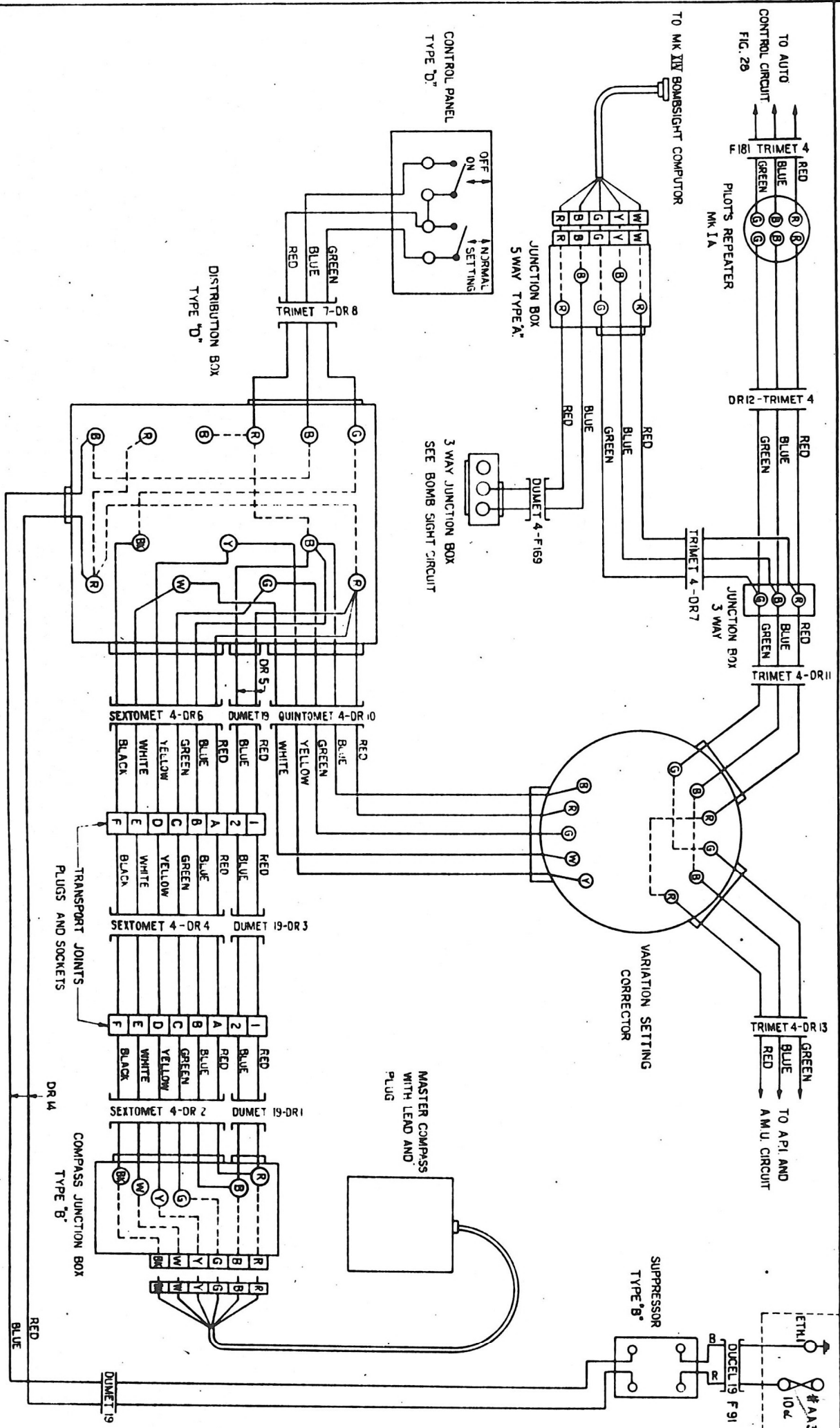

FIG. 29

ROUTING CHART — GENERAL SERVICES

FIG. 29

D.R. COMPASS - D.R.



EQUIPMENT

TITLE	10.0.	CON. REF.	NAVIGATOR'S PANEL.
-------	-------	-----------	--------------------

G.P.I. AND A.M.U.

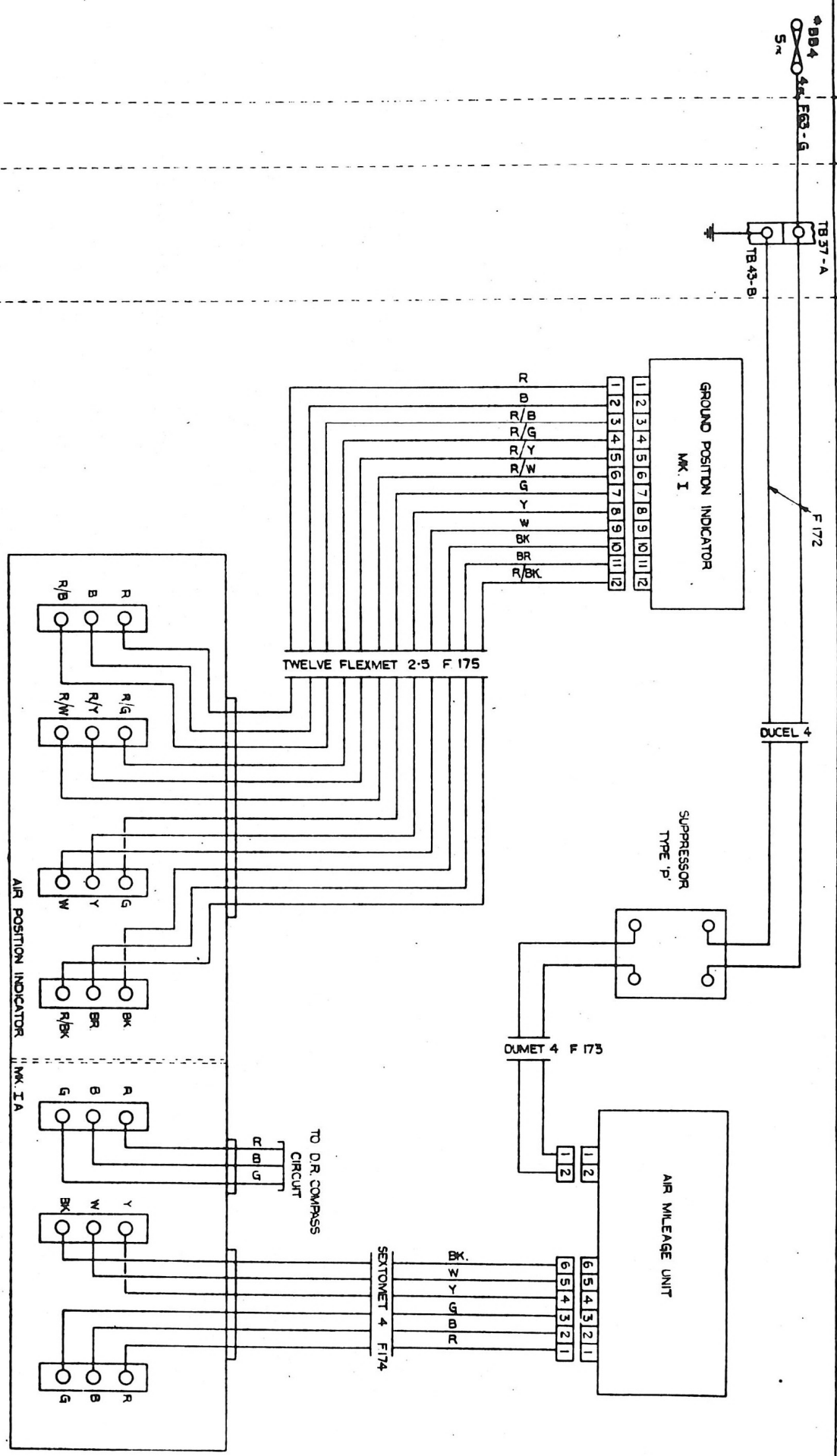

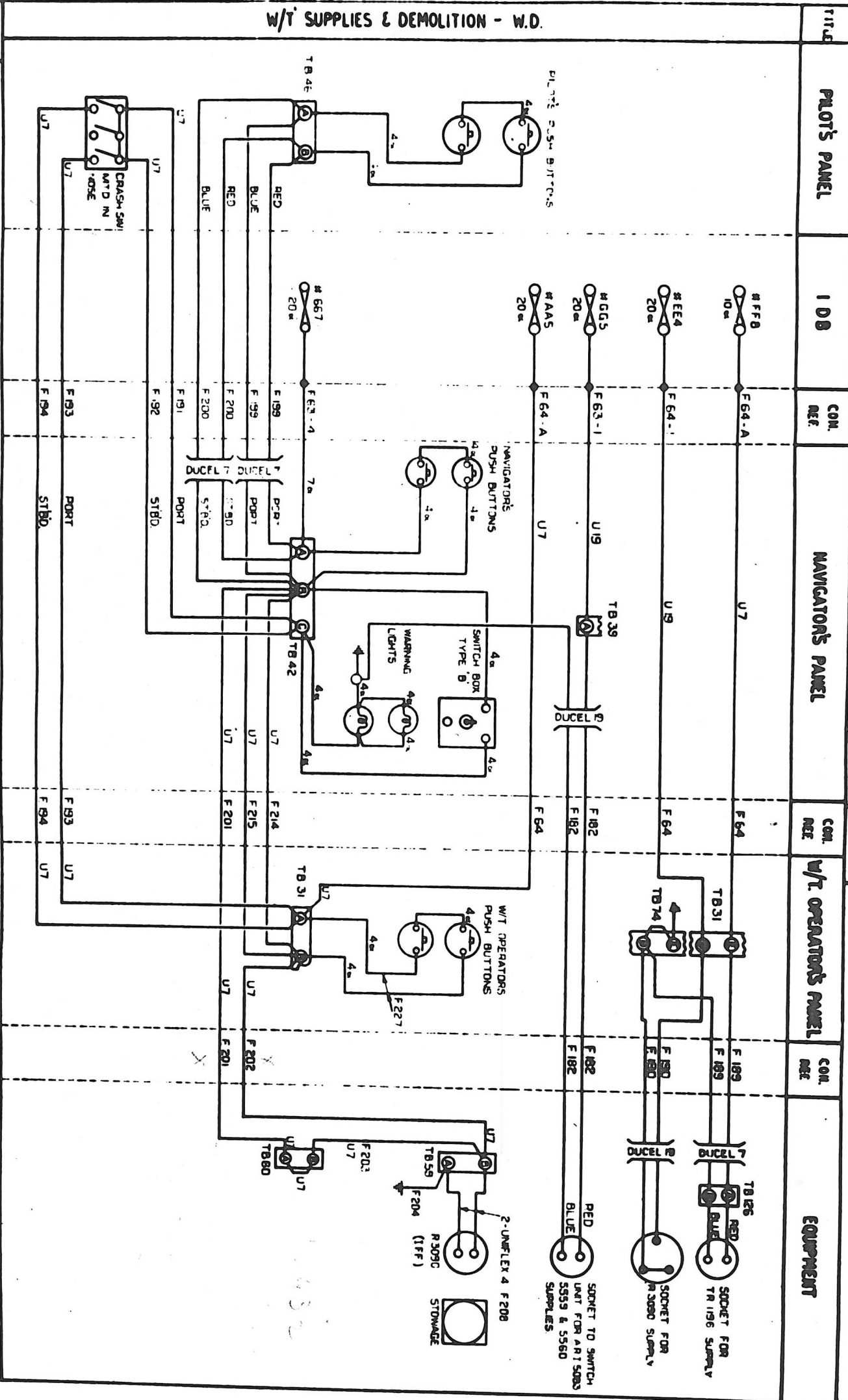

W/T SUPPLIES & DEMOLITION - W.D.

TITLE	RADAR EQUIPMENT	CON REF	3 D.B.	CON REF	EQUIPMENT	CON REF	STABILIZED SCANNER PLATFORM.
-------	-----------------	---------	--------	---------	-----------	---------	------------------------------

MOTOR GENERATOR FOR SCANNING UNIT

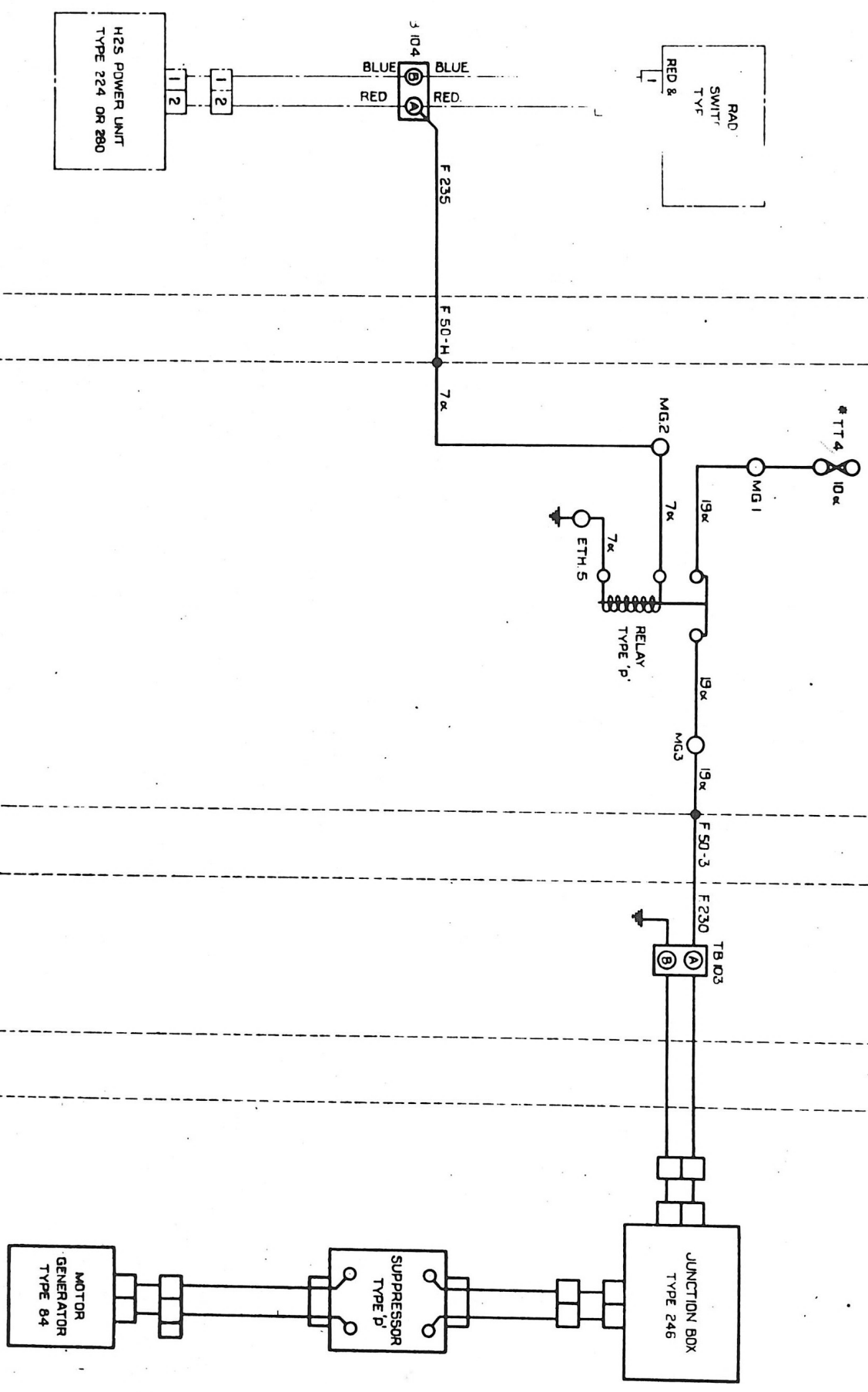

REAR TURRET SUPPLY BOULTON PAUL TYPE 'D' & INTERNAL DISTRIBUTION

TITLE	2P	3P	COM REF	5DB	COM REF	8P	COM REF	EQUIPMENT	COM REF	REAR TURRET (BOULTON PAUL TYPE 'D')

AP 2847 A & B VOL. I SECT. 6 CHAP. I

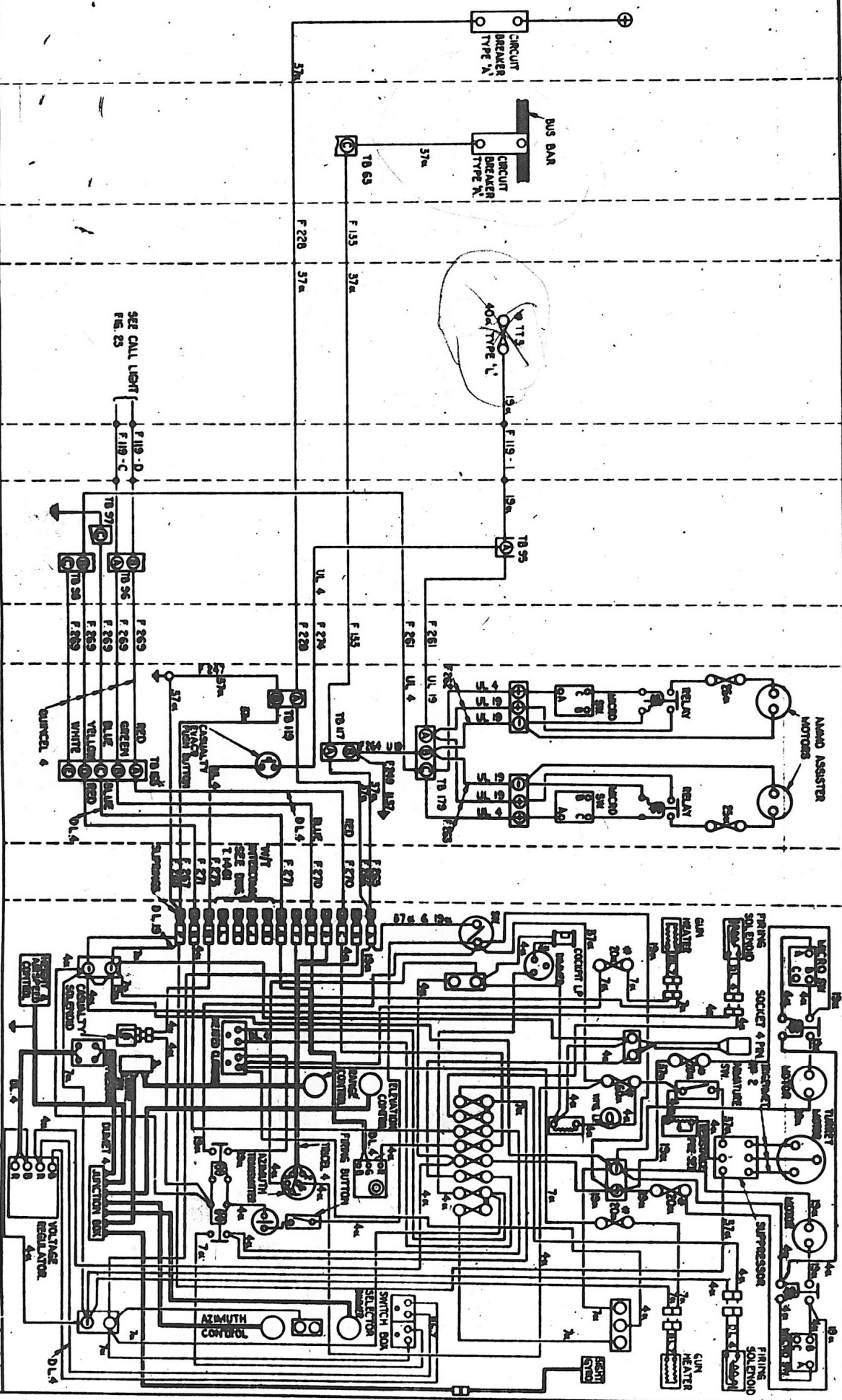

SEE CALL LIGHT  
FIG. 23

TEMPORARY DISPOSAL OF BOW OF DINGHY WHILE ARRANGING STORAGE OF EMERGENCY PACKS, ETC.

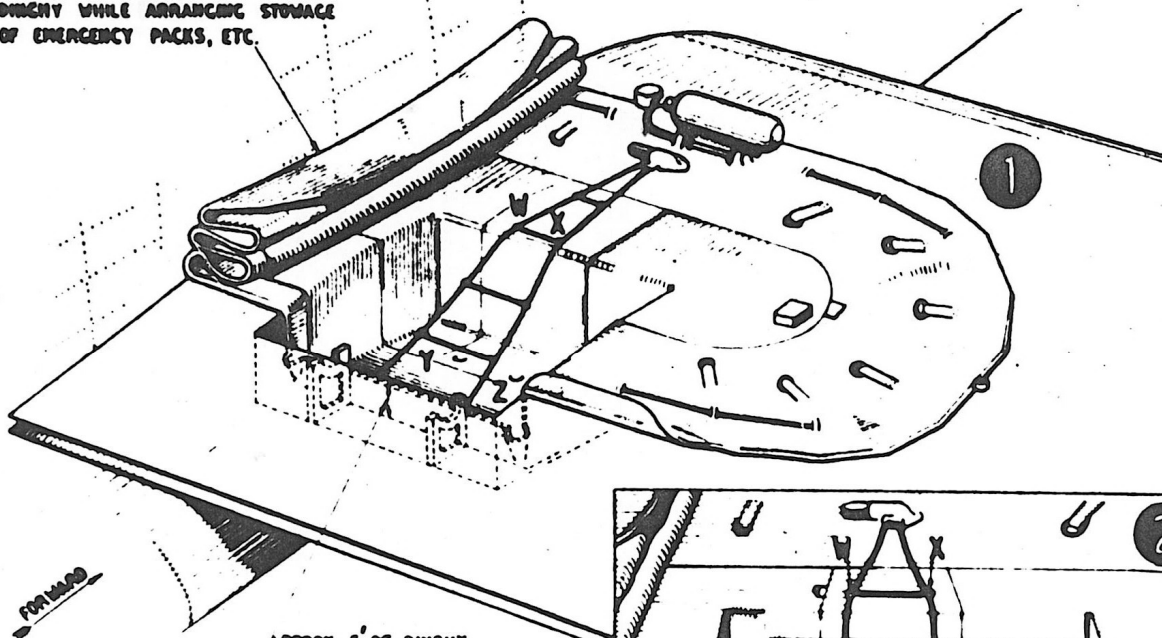

APPROX. 5' OF DINGHY VERTICAL, RESTING AGAINST CYLINDER BEARERS

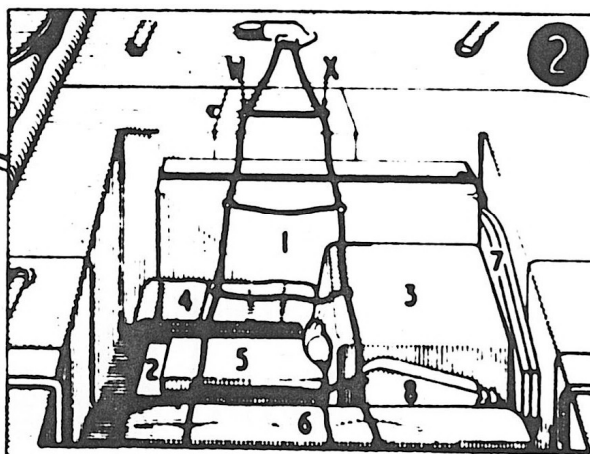
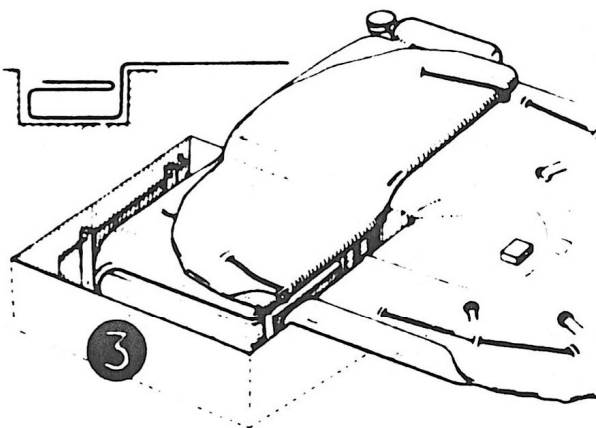

- 1 AVRO TYPE PACK
- 2 TYPE 4 PACK
- 3 DINGHY RADIO
- 4 WEATHER APRON, ON TYPE 4 PACK, AND DOWN SIDE
- 5 SAIL, ON TYPE 4 PACK
- 6 MAST AND RUBBER, IN BAG
- 7 PADDLES
- 8 BELLOWS

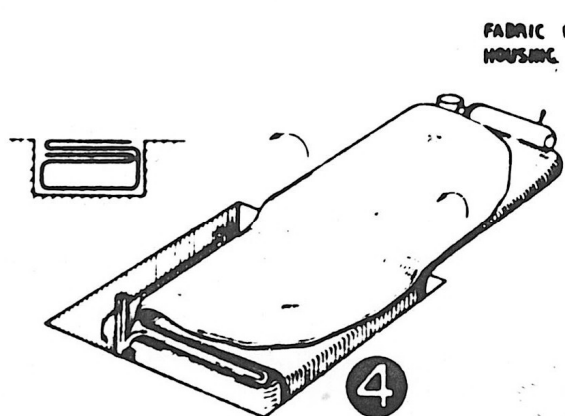

FABRIC CYLINDER HOUSING

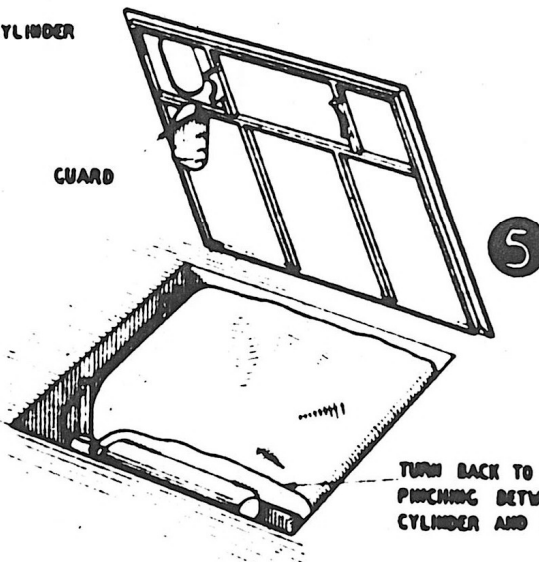

GUARD

TURN BACK TO PREVENT PINCHING BETWEEN CYLINDER AND COVER

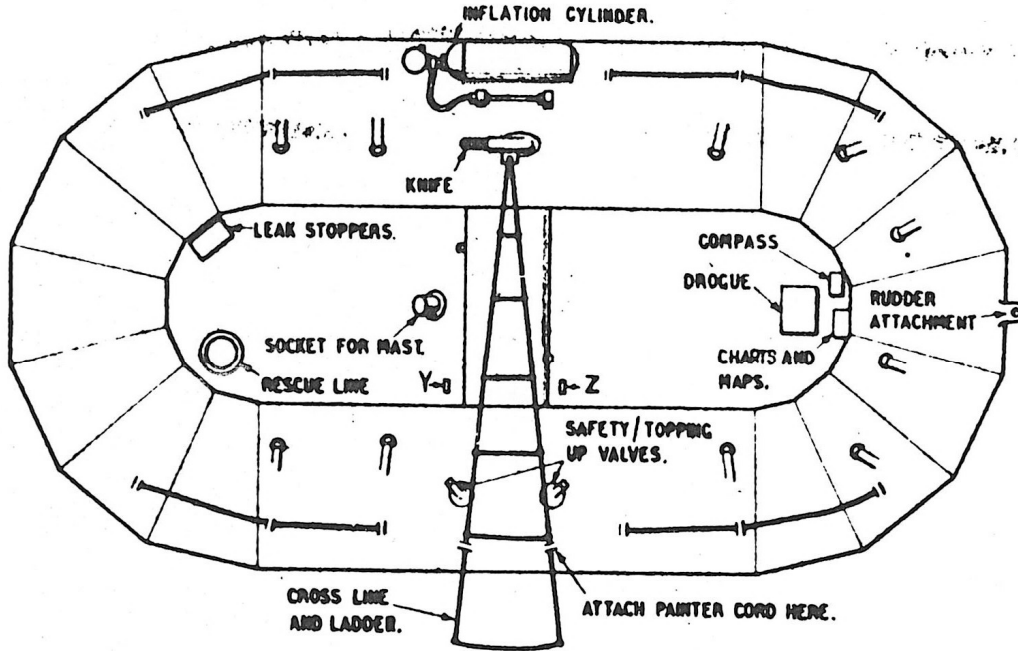

**STOWING INSTRUCTIONS**

1. Lay the dinghy, thoroughly deflated, on wing surface with inflation cylinder forward and lined up to out position of bearers. Deflate by means of pump until all creases appear on inside edges.
2. Check that the inflation pipe is connected to the correct valve of the inflation manifold, is with the operating head towards the bow of the dinghy and towards the inboard side of the stowage.
3. Ease the dinghy into the stowage as indicated in fig 4 leaving approximately 5 in of the dinghy vertical against the cylinder bearers.
4. Withdraw dust caps from safety/topping up valves to ensure pressure relief after inflation.
5. Lay dinghy painter cord on stowage floor between bearers, one end (as labelled) tied to cylinder bearer, the other end tied to dinghy at position indicated above. Cord 20 ft. long, 8 oz. F.32.
6. Place emergency packs, sailing gear bags, paddles, bellows, weather apron (if not integral with dinghy) and dinghy radio in positions shown in fig 4, taking care that all are below the dinghy ladder. Attach these items to dinghy at positions indicated in notes in fig 6.
7. Complete folds shown in fig 4 so that cylinder housing rests on cylinder bearers in stowage.
8. Leak cylinder into its housing on the dinghy and place on bearers in such a way that crutches in stowage end on cover rest on fabric of cylinder housing, and NOT on dinghy shell. See fig 4.
9. Check by trial that stowage cover can be correctly sealed without necessity for more than 30 lbs external pressure. To achieve this it may be necessary to displace folds locally in order to eliminate high spots.
10. Connect inflation pipe from dinghy to operating head of inflation cylinder.
11. Connect the remote manual cable to operating head, and wire and lock operating head drum. It should be noted that a guard is provided on the stowage cover to separate operating cable from dinghy.
12. Reduce length of electric lead to 8 in (measured from top of plug pins to point at which lead leaves stowage on operating head) by hooking and banding firmly with insulating tape. Connect plug into socket.
13. Ensure that dinghy is clear of operating cable, assemble and fix cover by means of screws, see detail. Check that guard on cover correctly separates dinghy from cable, by removal of inspection window if necessary. Seal by applying one thin coat of B.2 or Coric Clear, No 0.3638 adhesive on surface to be covered by fabric strip. Place 3 in fabric strip in position, apply a further coat of adhesive, allow to dry, and re-connections.

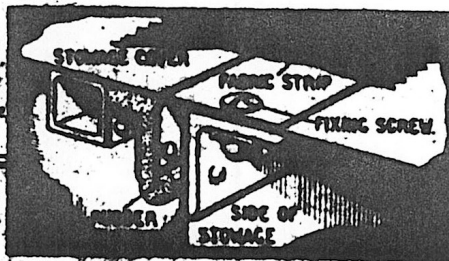

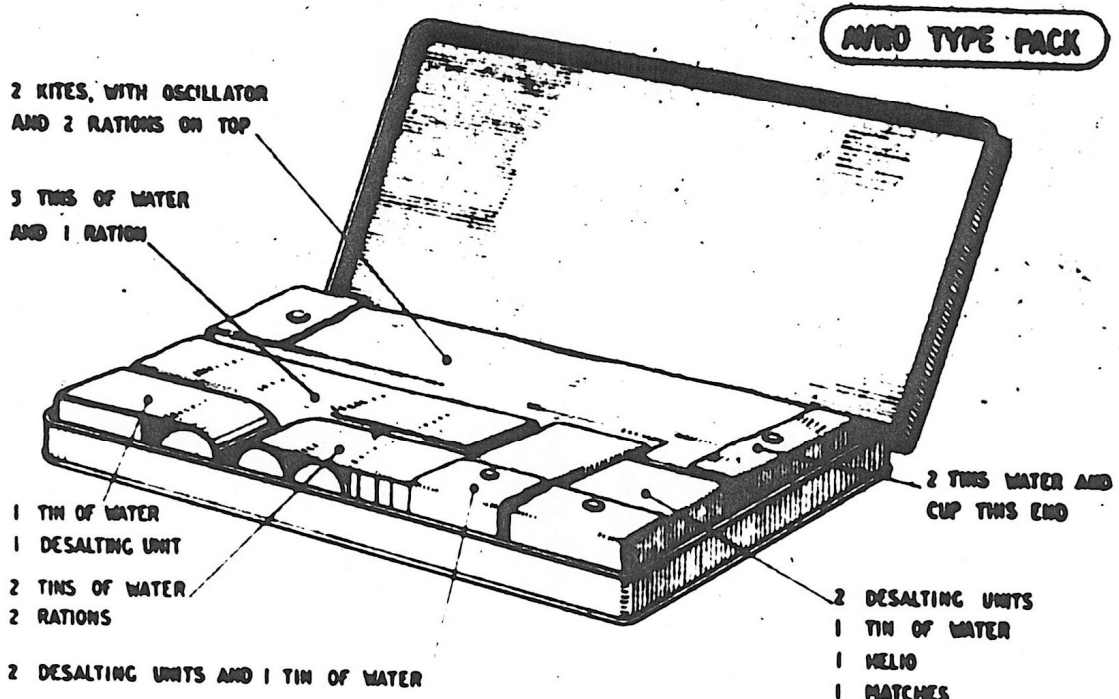

### SECURING EQUIPMENT IN DINGHY

Avro type pack connected to patch Z by its own lanyard  
 Type 4 pack connected to patch Y by its own lanyard  
 Dinghy radio connected to patch Z by 16oz cord F 32  
 Mast and rudder in container connected by two 16oz cords to patches Y and Z. These patches are shown in fig 5  
 Bellows in bag attached to crossline at X by 2ft length of 16oz cord, so that bellows can be removed without cutting cord  
 Riddles attached to dinghy crossline at X by 2ft of cord 4 F 35  
 All connecting cords must be 12in longer than distance between attachment to dinghy and attachment to item, to allow freedom of movement when emerging  
 Cords must not lie over any of the stowed items  
 Dinghy crossline must lie OVER all the stowed items  
 Weather apron lashed to type 4 pack in position shown in fig 4, unless integral with dinghy  
 Sail bag lashed to mast and rudder container at position shown in fig 4

★ Note - In cases where dinghy is not provided with patches Y and Z, Avro type pack and dinghy radio are to be connected to dinghy crossline at X, type 4 pack at W, and mast and rudder container connected to crossline at W and X. See fig 4

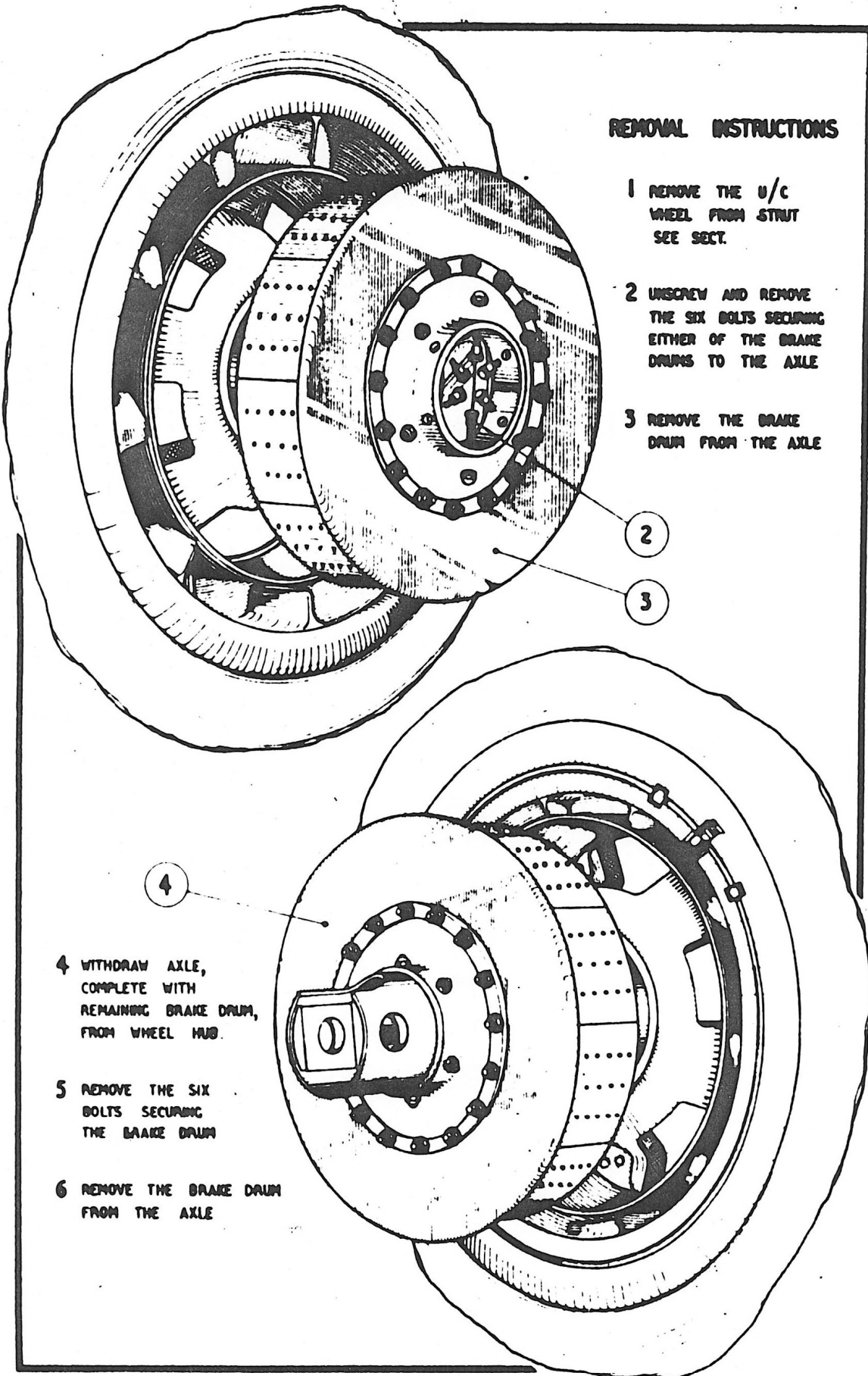

**REMOVAL INSTRUCTIONS**

- 1 REMOVE THE u/c WHEEL FROM STRUT SEE SECT.
- 2 UNSCREW AND REMOVE THE SIX BOLTS SECURING EITHER OF THE BRAKE DRUMS TO THE AXLE
- 3 REMOVE THE BRAKE DRUM FROM THE AXLE

4 WITHDRAW AXLE, COMPLETE WITH REMAINING BRAKE DRUM, FROM WHEEL HUB.

5 REMOVE THE SIX BOLTS SECURING THE BRAKE DRUM

6 REMOVE THE BRAKE DRUM FROM THE AXLE

ISSUED BY  
 USMC - 1942  
 ANDRE L. CLINE  
 DRAWN BY  
 A. N.  
 SCALE  
 1" = 1'-0"

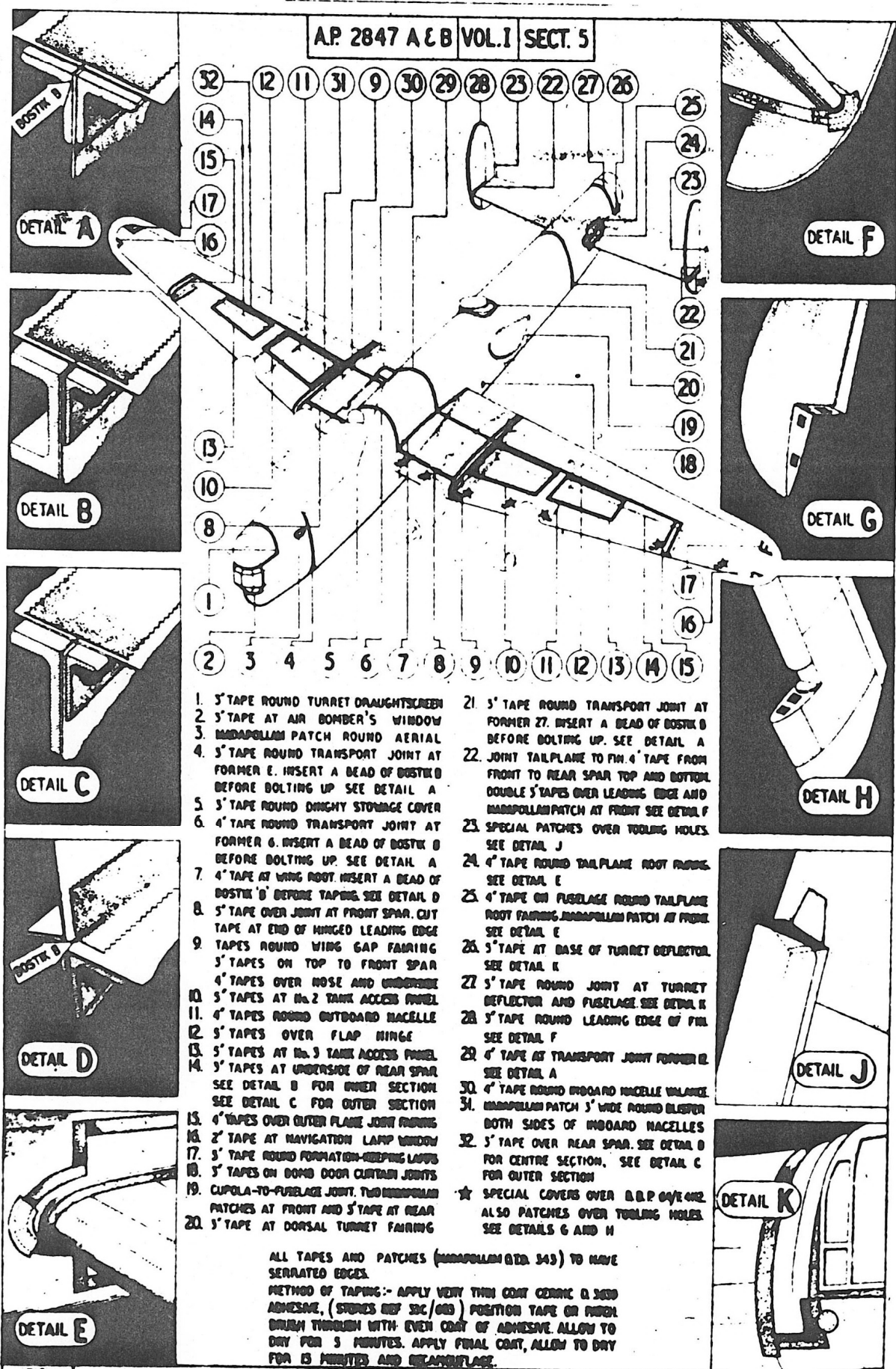

1. 5" TAPE ROUND TURRET DRAUGHTSCREEN
  2. 5" TAPE AT AIR BOMBER'S WINDOW
  3. MIDSPOLLUM PATCH ROUND AERIAL
  4. 5" TAPE ROUND TRANSPORT JOINT AT FORMER E. INSERT A BEAD OF BOSTIK B BEFORE BOLTING UP. SEE DETAIL A
  5. 5" TAPE ROUND DUNGY STORAGE COVER
  6. 4" TAPE ROUND TRANSPORT JOINT AT FORMER B. INSERT A BEAD OF BOSTIK B BEFORE BOLTING UP. SEE DETAIL A
  7. 4" TAPE AT WING ROOT. INSERT A BEAD OF BOSTIK B BEFORE TAPING. SEE DETAIL D
  8. 5" TAPE OVER JOINT AT FRONT SPAR. CUT TAPE AT END OF HINGED LEADING EDGE
  9. TAPES ROUND WING GAP FAIRING  
5" TAPES ON TOP TO FRONT SPAR  
4" TAPES OVER NOSE AND UNDERSIDE
  10. 5" TAPES AT No. 2 TANK ACCESS PANEL
  11. 4" TAPES ROUND OUTBOARD MACELLE
  12. 5" TAPES OVER FLAP HINGE
  13. 5" TAPES AT No. 3 TANK ACCESS PANEL
  14. 5" TAPES AT UNDERSIDE OF REAR SPAR. SEE DETAIL B FOR INNER SECTION. SEE DETAIL C FOR OUTER SECTION
  15. 4" TAPES OVER OUTER FLARE JOINT FAIRING
  16. 2" TAPE AT NAVIGATION LAMP WINDOW
  17. 5" TAPE ROUND FORMATION-KEEPING LAMP
  18. 5" TAPES ON BOMB DOOR CURTAIN JOINTS
  19. CUPOLA-TO-FUSELAGE JOINT. TWO MIDSPOLLUM PATCHES AT FRONT AND 5" TAPE AT REAR
  20. 5" TAPE AT DORSAL TURRET FAIRING
  21. 5" TAPE ROUND TRANSPORT JOINT AT FORMER 27. INSERT A BEAD OF BOSTIK B BEFORE BOLTING UP. SEE DETAIL A
  22. JOINT TAILPLANE TO FIN. 4" TAPE FROM FRONT TO REAR SPAR TOP AND BOTTOM. DOUBLE 5" TAPES OVER LEADING EDGE AND MIDSPOLLUM PATCH AT FRONT. SEE DETAIL F
  23. SPECIAL PATCHES OVER TOOLING HOLES. SEE DETAIL J
  24. 4" TAPE ROUND TAILPLANE ROOT FAIRING. SEE DETAIL E
  25. 4" TAPE ON FUSELAGE ROUND TAILPLANE ROOT FAIRING. MIDSPOLLUM PATCH AT FRONT. SEE DETAIL E
  26. 5" TAPE AT BASE OF TURRET DEFLECTOR. SEE DETAIL K
  27. 5" TAPE ROUND JOINT AT TURRET DEFLECTOR AND FUSELAGE. SEE DETAIL K
  28. 5" TAPE ROUND LEADING EDGE OF FIN. SEE DETAIL F
  29. 4" TAPE AT TRANSPORT JOINT FORMER 12. SEE DETAIL A
  30. 4" TAPE ROUND MIDBOARD MACELLE VALANCE
  31. MIDSPOLLUM PATCH 5" WIDE ROUND BLISTER BOTH SIDES OF MIDBOARD MACELLES
  32. 5" TAPE OVER REAR SPAR. SEE DETAIL B FOR CENTRE SECTION. SEE DETAIL C FOR OUTER SECTION
- ★ SPECIAL COVERS OVER B.B.P. 04/1412. ALSO PATCHES OVER TOOLING HOLES. SEE DETAILS G AND H

ALL TAPES AND PATCHES (MIDSPOLLUM STD. 343) TO HAVE SERRATED EDGES.  
 METHOD OF TAPING:- APPLY VERY THIN COAT CERRO D. 5000 ADHESIVE, (STORES REF. SEC/000) POSITION TAPE ON SURFACE. RUB THROUGH WITH EVEN COAT OF ADHESIVE. ALLOW TO DRY FOR 5 MINUTES. APPLY FINAL COAT, ALLOW TO DRY FOR 15 MINUTES AND REPAIR FLARE.

FIG. 5

# WEATHERPROOFING

FIG. 5

REFERENCES

- 1 SEALING WASHERS AT CUT-OUTS FOR SUB-FRAME LUGS
- 2 COVER FOR COUPLING OF ACCESSORY GEARBOX DRIVE
- 3 FLAME SWITCHES - FOUR ON EACH FIREWALL
- 4 COVER FOR ENGINE CONTROL COUNTERSHAFT.
- 5 OIL AND WATER DRAINS TANK
- 6 OIL SEPARATOR TANKS TWO ARE ON STANDBOARD MIDBOARD FIREWALL, ONE ON PORT MIDBOARD FIREWALL, NONE ARE ON OUTBOARD FIREWALLS
- 7 FAIRLEAD FOR ELECTRICAL SERVICES CABLE
- 8 FAIRLEAD FOR ENGINE SERVICES CABLE
- 9 BOOST PIPE CONNECTOR
- 10 DOPER PIPE CONNECTOR
- 11 FUEL VENT PIPE CONNECTOR
- 12 AIR SUPPLY PIPE CONNECTOR
- 13 FAIRLEAD FOR FUEL FLOWMETER CABLE
- 14 FAIRLEAD FOR FLAME SW AND PRESSURE CUT-OUT CABLES
- 15 FAIRLEAD FOR ENGINE STARTER CABLE
- 16 FAIRLEAD FOR IGNITION CABLE
- 17 FUEL FILTER
- 18 FAIRLEAD FOR ACCESSORY DRAIN - MIDBOARD FIREWALL
- 19 FAIRLEAD FOR CABIN HEATER COOLANT PIPES - INBOARD
- 20 FAIRLEAD FOR OIL SUPPLY PIPE [FIREWALL]
- 21 FAIRLEAD FOR OIL RETURN PIPE
- 22 FAIRLEAD FOR OIL VENT PIPE
- 23 FAIRLEAD FOR FIRE EXTINGUISHER PIPE - ONE BOTTLE SYSTEM
- 24 FAIRLEADS FOR FIRE EXTINGUISHER PIPES - TWO BOTTLE SYSTEM
- 25 FAIRLEAD FOR FEATHERING UNIT SUPPLY PIPE
- 26 FUEL PUMP SUPPRESSORS - MIDBOARD FIREWALLS
- 27 FAIRLEAD FOR OIL SEPARATOR PIPES - MIDBOARD FIREWALLS
- 28 FAIRLEAD FOR BOOST CUT OUT CABLE
- 29 FEATHERING PUMP ON AFT FACE OF FIREWALLS
- 30 DOPER VALVE ON AFT FACE OF OUTBOARD FIREWALLS
- 31 OIL AND WATER TRAP ON AFT FACE OF PORT MIDBOARD FIREWALLS
- 32 NOMENCLATURE CARD HOLDER
- 33 DELAY ACTION SWITCH ON AFT FACE OF OUTBOARD FIREWALLS
- 34 REGULATOR VALVE ON AFT FACE OF STANDBOARD MIDBOARD FIREWALL

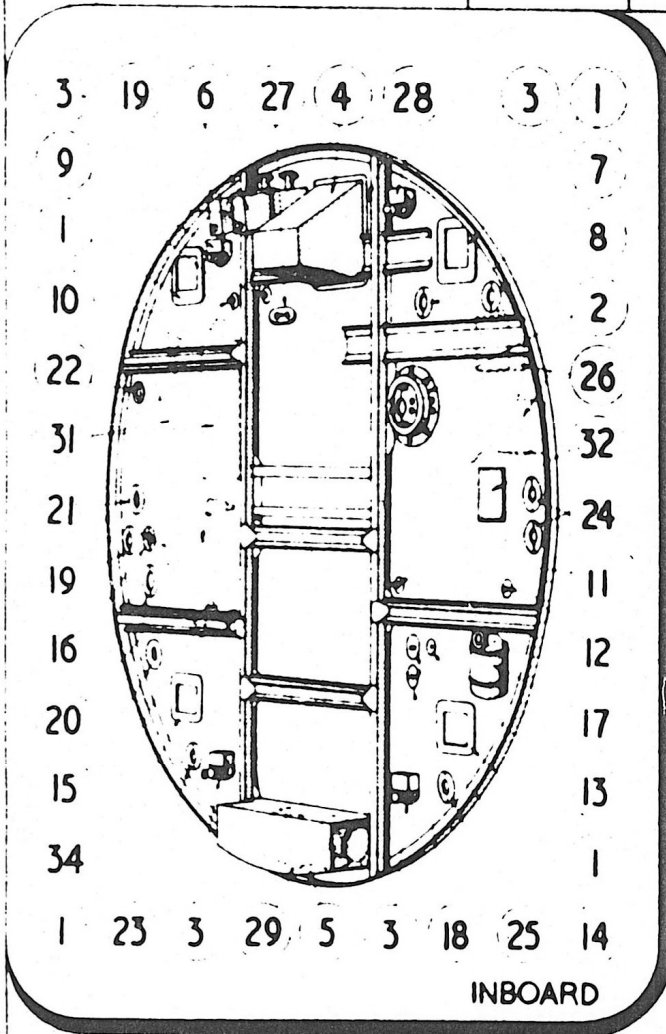

INBOARD

REMOVAL INSTRUCTIONS

INBOARD FIREWALLS ONLY

DISCONNECT ACCESSORY DRAINPIPE AT 'Y' PIECE AFT OF FIREWALL  
 DISCONNECT PIPES TO OIL SEPARATOR TANKS AT AUXILIARY GEARBOX  
 DISCONNECT PIPE TO OIL-WATER TRAP AT 'Y' PIECE, AND DELIVERY PIPE TO PRESSURE REGULATING VALVE AT FIREWALL - UNCLIP PIPES  
 REMOVE PULSOMETER PUMP SEE FIG 14  
 DISCONNECT BOOST AND DOPER PIPES AT UNIONS, AND UNCLIP FROM REAR FACE OF FIREWALL

OUTBOARD FIREWALLS ONLY

DISCONNECT ELECTRICAL CABLES COMING AFT AT TERMINAL BLOCKS ON REAR FACE OF FIREWALL  
 DISCONNECT BOOST PIPE AT UNION, AND FUEL SUPPLY PIPE TO DOPER VALVE AT 'Y' PIECE AND UNCLIP PIPES FROM REAR FACE OF FIREWALL

INBOARD AND OUTBOARD FIREWALLS

REMOVE ALL SPLIT FAIRLEADS IN ORDER THAT PIPES AND CABLES CAN BE WITHDRAWN THROUGH FIREWALL  
 DISCONNECT AIR SUPPLY PIPE AT UNION ON AFT FACE OF FIREWALL, AND UNCLIP  
 THE OIL TANK BEING EMPTY, DISCONNECT THE PIPE FROM THE OIL TANK TO THE FEATHERING PUMP AT THE PUMP, AND REMOVE PUMP  
 REMOVE CONTROL COVER FROM FIREWALL AND DISCONNECT ENGINE CONTROL RODS AT TURBUCLIPS  
 UNCLIP IGNITION CABLES FROM AFT FACE OF FIREWALL  
 DISCONNECT FUEL VENT PIPE AT UNION ON AFT FACE OF FIREWALL  
 DISCONNECT PIPE TO FUEL FILTER AT CONNECTION ON AFT FACE OF FIREWALL  
 REMOVE SEALING WASHERS AT CUT-OUTS FOR SUB-FRAME LUGS UNBOLT AND REMOVE CLIPS SECURING FIREWALL TO SUB-FRAME HOLDING FIREWALL SECURELY. DRAW FORWARD OFF SUB-FRAME LUGS ALLOWING ALL PIPES AND CABLES TO PASS THROUGH FIREWALL

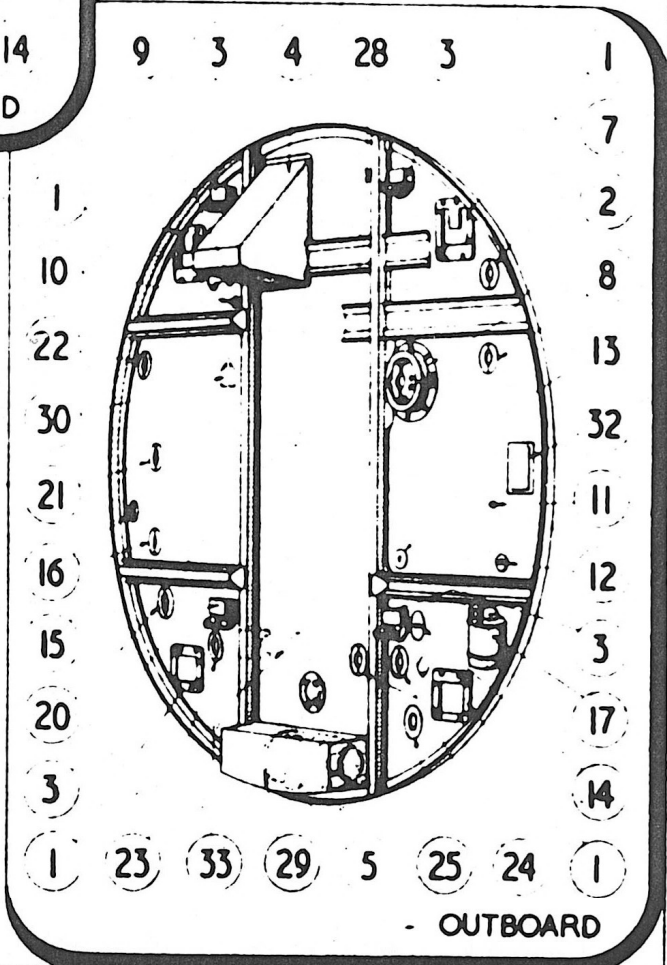

OUTBOARD

OUTBOARD ENGINE SUB-FRAME

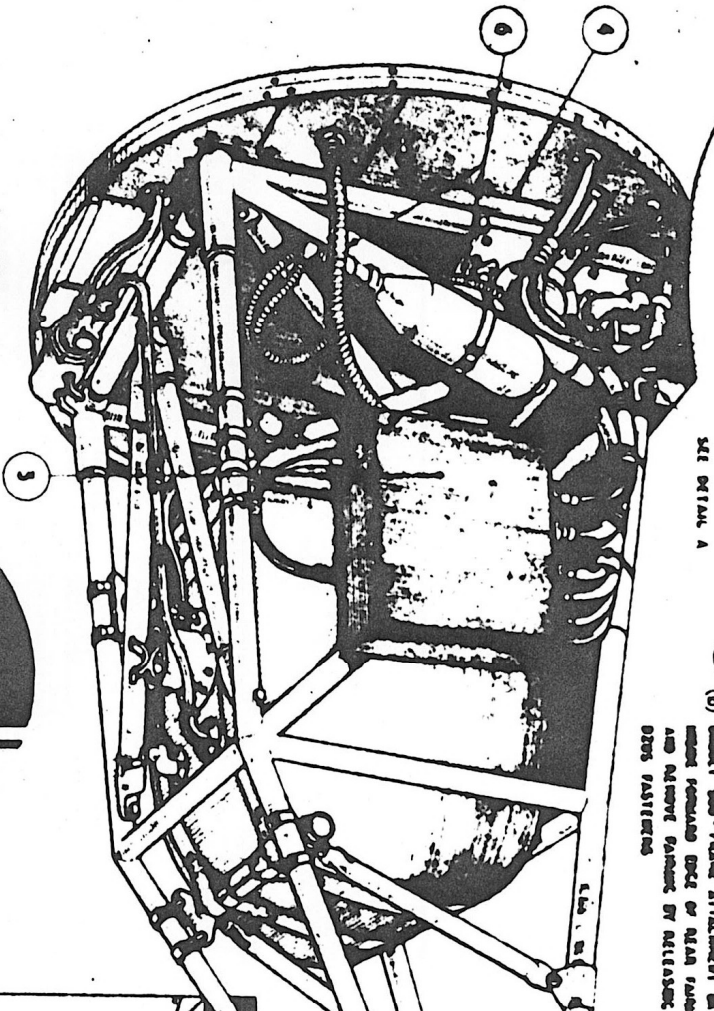

1 REMOVE POWER PLANT (SEE FIG. 10)

SEE DETAIL A

2 REMOVE MACELE FAIRINGS AS FOLLOWS:  
 (a) REMOVE OZOS FASTENERS AND REMOVE PANELS 1, 2 & 3.  
 (b) REMOVE SUB-FRAME ATTACHMENT BOLTS FROM FORWARD END OF REAR FAIRING AND REMOVE FAIRING BY RELEASED OZOS FASTENERS

3 DISCONNECT AT JUNCTION BOSS AND UNCLIP FROM SUB-FRAME  
 ALL ELECTRICAL CABLES PASSING FROM FRONT SPAN INTO SUB-FRAME  
 NOTE: WARMING CABLES TO BE DISCONNECTED AT FORWARD, UNCLIPPED AND COILED AT THE SPAN

4 DISCONNECT PNEUMATIC BOOST AND BOPIN PIPES AT UNION  
 JUST FORWARD OF MACELE  
 FROM END ATTACHMENT SEE DETAIL B

5 DISCONNECT ENGINE CONTROL ROSS BETWEEN FRONT SPAN AND OUTBOARD AND COIL BOOST CUT-OFF CONTROL CABLE IN LEADING EDGE.

6 DISCONNECT FUEL SUPPLY PIPE AND FUEL VENT PIPE.  
 7 REMOVE BOLTS SECURING SUB-FRAME TO CHASSIS SEE DETAILS A & B

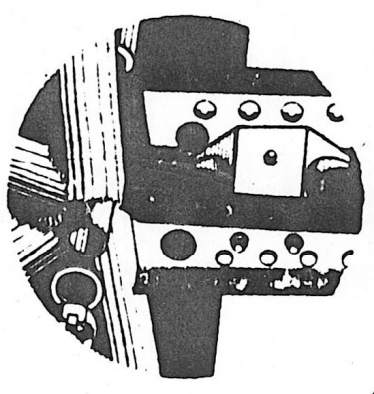

DETAIL A

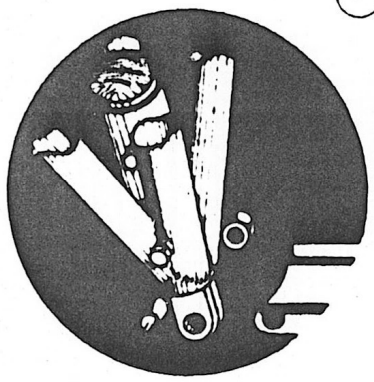

DETAIL B

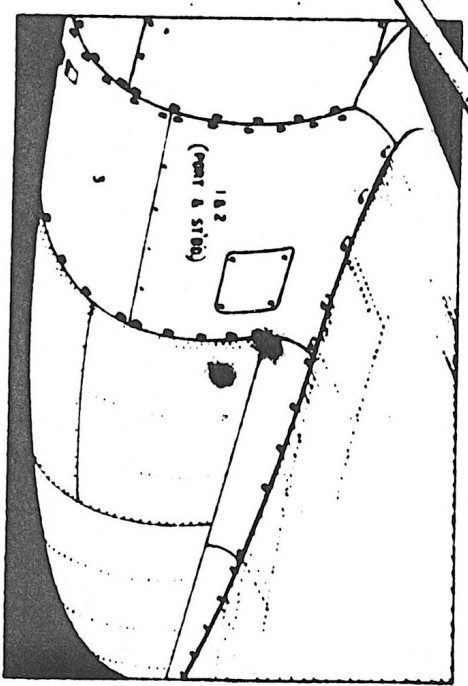

DETAILS OF REAR MACELE FAIRINGS.

NOTE: ON REPLACEMENT THE FORWARD FRONT SPAN ATTACHMENT BOLT MUST BE INSERTED FROM INSIDE THE SUB-FRAME.

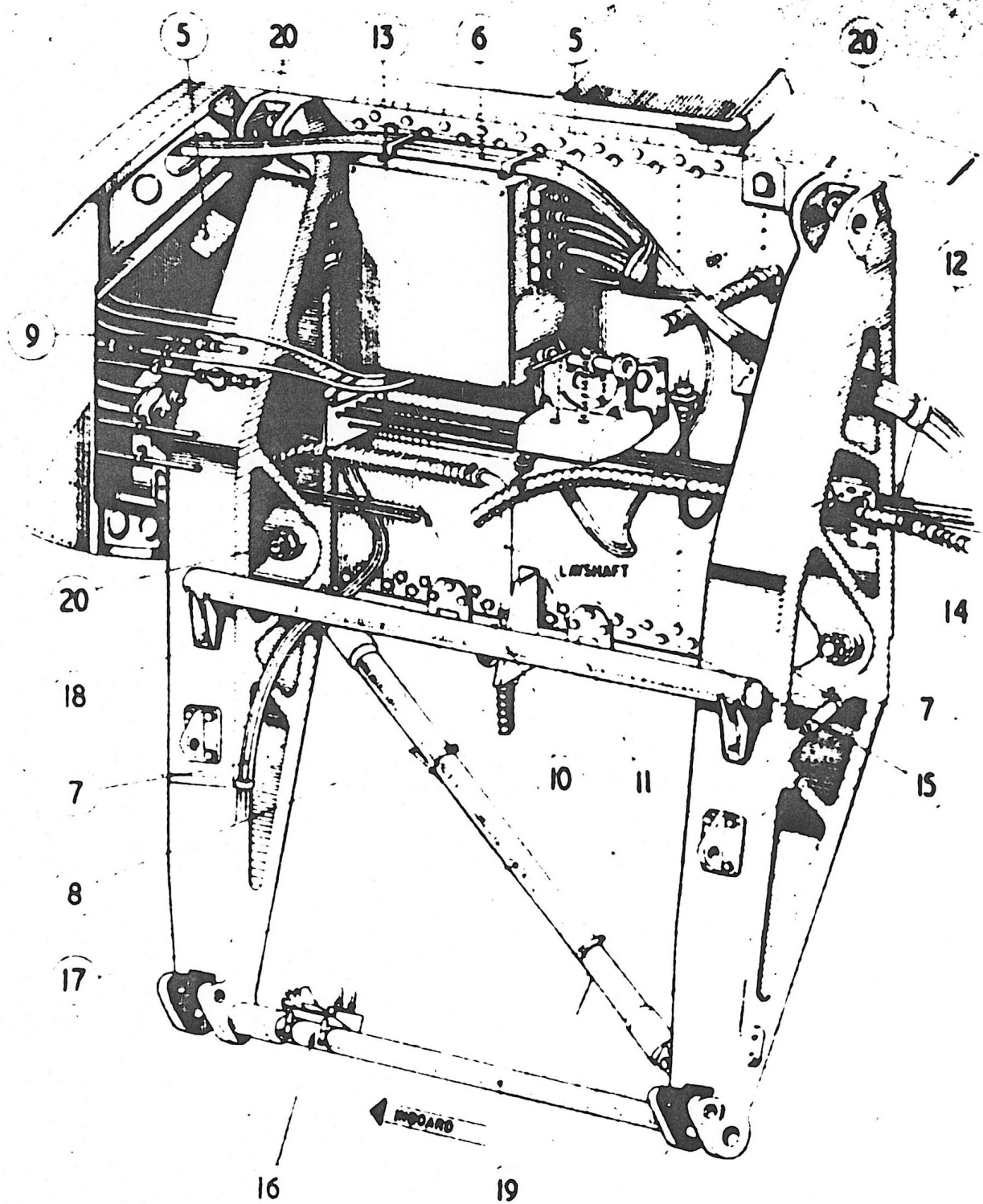

1. REMOVE THE ENGINE. SEE FIG 10
2. REMOVE ENGINE SUB-FRAME SEE FIG 10
3. REMOVE MAIN WHEEL UNIT SEE FIG 20
4. REMOVE BOLTS SECURING MAIN WHEEL DOOR HINGE BEAM TO SUPPORT BEAM

FOR FURTHER DETAILS AND METHOD OF REMOVAL SEE FIG. 23.

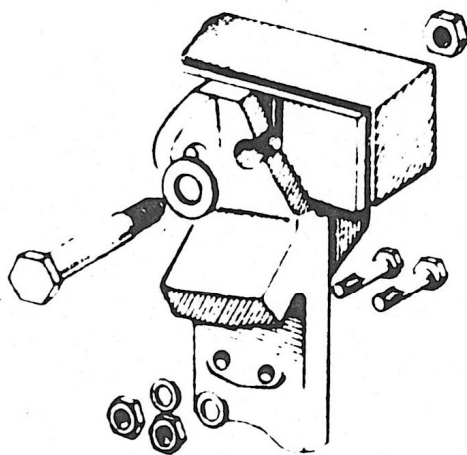

DETAIL A

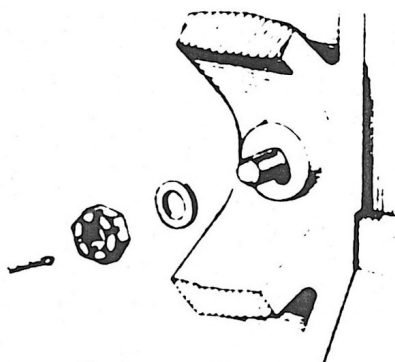

DETAIL B

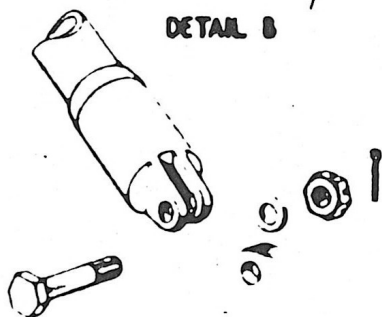

DETAIL C



DETAIL D

## REMOVAL INSTRUCTIONS

5. DISCONNECT ELECTRICAL CONDUITS AT JUNCTION BOX ON FRONT SPAR AND WITHDRAW THROUGH BEAM.
6. DISCONNECT ELECTRICAL CONDUITS AT JUNCTION BOX ON OUTBOARD SUBFRAME, WITHDRAW THROUGH TUBE IN LEADING EDGE AND WITHDRAW THROUGH BEAM.
7. REMOVE CLIPS SECURING ELECTRICAL CABLES TO BEAM.
8. REMOVE CLIPS SECURING PIPE TO DIAGONAL STRUT.
9. DISCONNECT HYDRAULIC PIPES AT JOINTS NEAR BEAM.
10. DISCONNECT FUEL COCK CONTROLS AT CONNECTOR BLOCK ON FRONT SPAR.
11. DISCONNECT FUEL CROSS FEED PIPE AT DRAIN VALVE AND WITHDRAW THROUGH BEAM.
12. DISCONNECT ENGINE CONTROL RODS AT EACH SIDE OF LAYSHAFT, SEE DETAIL D, AND REMOVE BOLTS SECURING LAYSHAFT TO BEAM.
13. DISCONNECT ENGINE CONTROL RODS AT SPROCKET BOX BETWEEN BEAMS AND AT FRONT SPAR IN FUSELAGE AND WITHDRAW THROUGH BEAM.
14. DISCONNECT FUEL FEED PIPE AND WITHDRAW THROUGH BEAM.
15. DISCONNECT BOOST CUT-OUT CABLE AT TURBUCKLE REAR OF BULKHEAD.
16. DISCONNECT ALL PIPES TO KI-CASS BRACKET.
17. REMOVE BOLTS SECURING DIAGONAL STRUT TO BEAMS. SEE DETAIL C.
18. REMOVE BOLTS SECURING CROSS-MEMBER TO BEAMS.
19. REMOVE LOWER BRACING STRUT.
20. REMOVE TOP ATTACHMENT BOLT, AND NUT FROM SPECIAL BOLT AT BOTTOM, LOWER BEAM FROM SPAR. SEE DETAILS A & B.

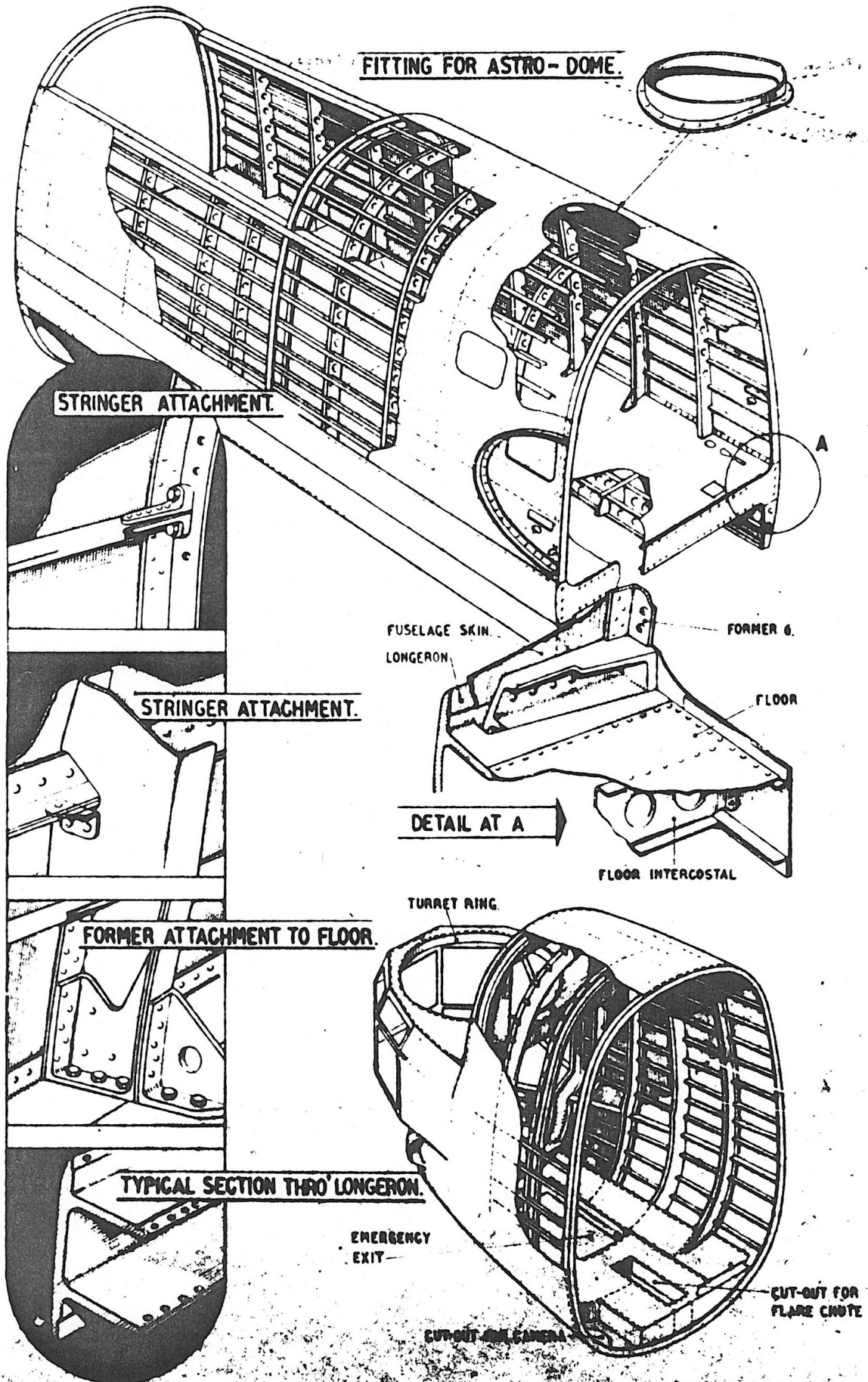

FOR FURTHER DETAILS SEE FIG. 6.

FIG. 1

# FUSELAGE SECTIONS (I)

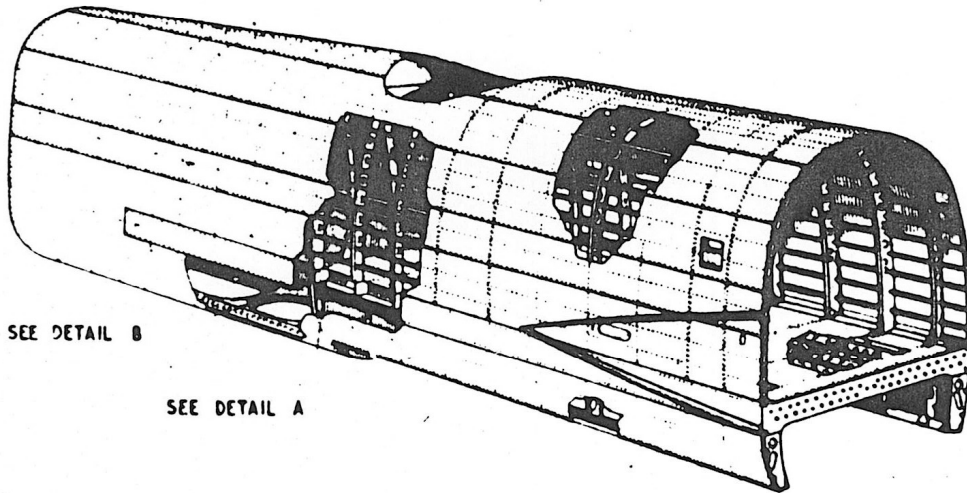

SEE DETAIL B

SEE DETAIL A

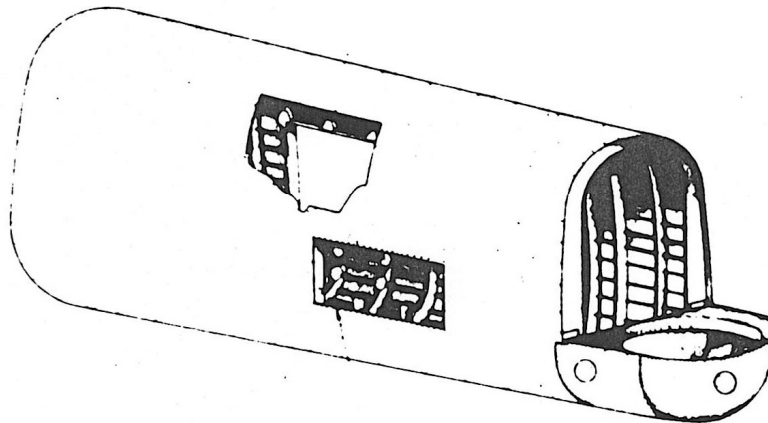

FOR FUSELAGE STRUCTURE  
AT TAILPLANE CUT-OUT,  
SEE DETAIL C BELOW

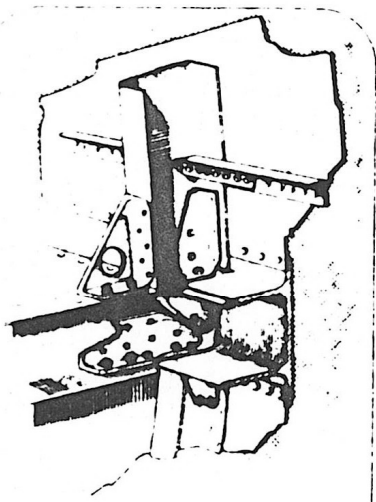

DETAIL OF FLOOR JOINT  
AT FORMER 22

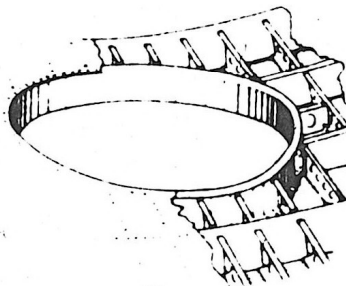

DETAIL OF RING IN  
REAR CENTRE SECTION FLOOR

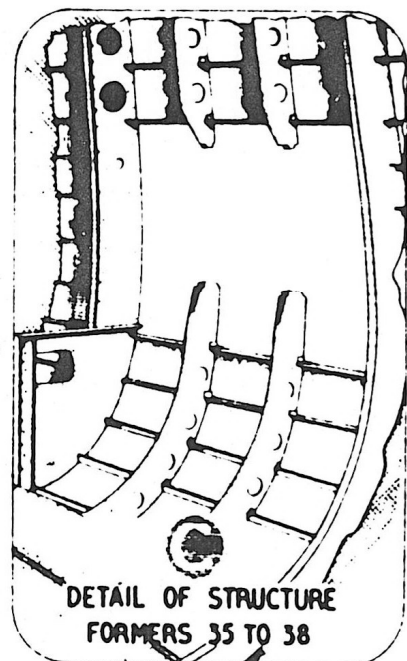

DETAIL OF STRUCTURE  
FORMERS 35 TO 38

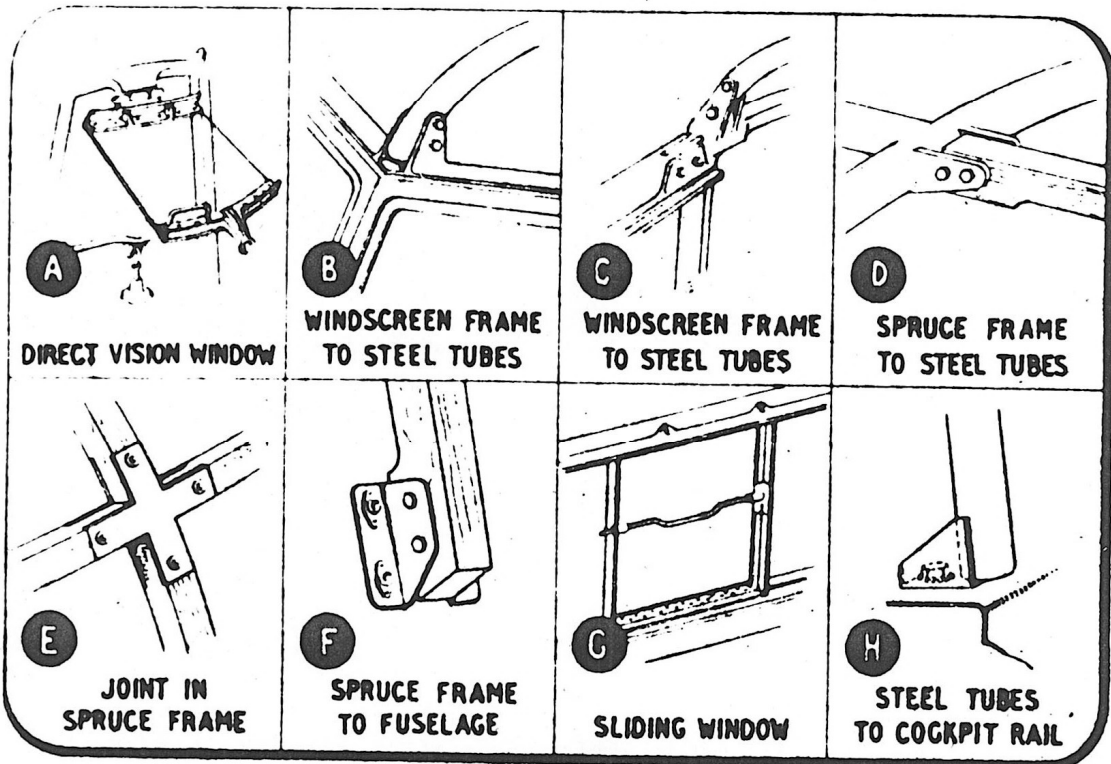
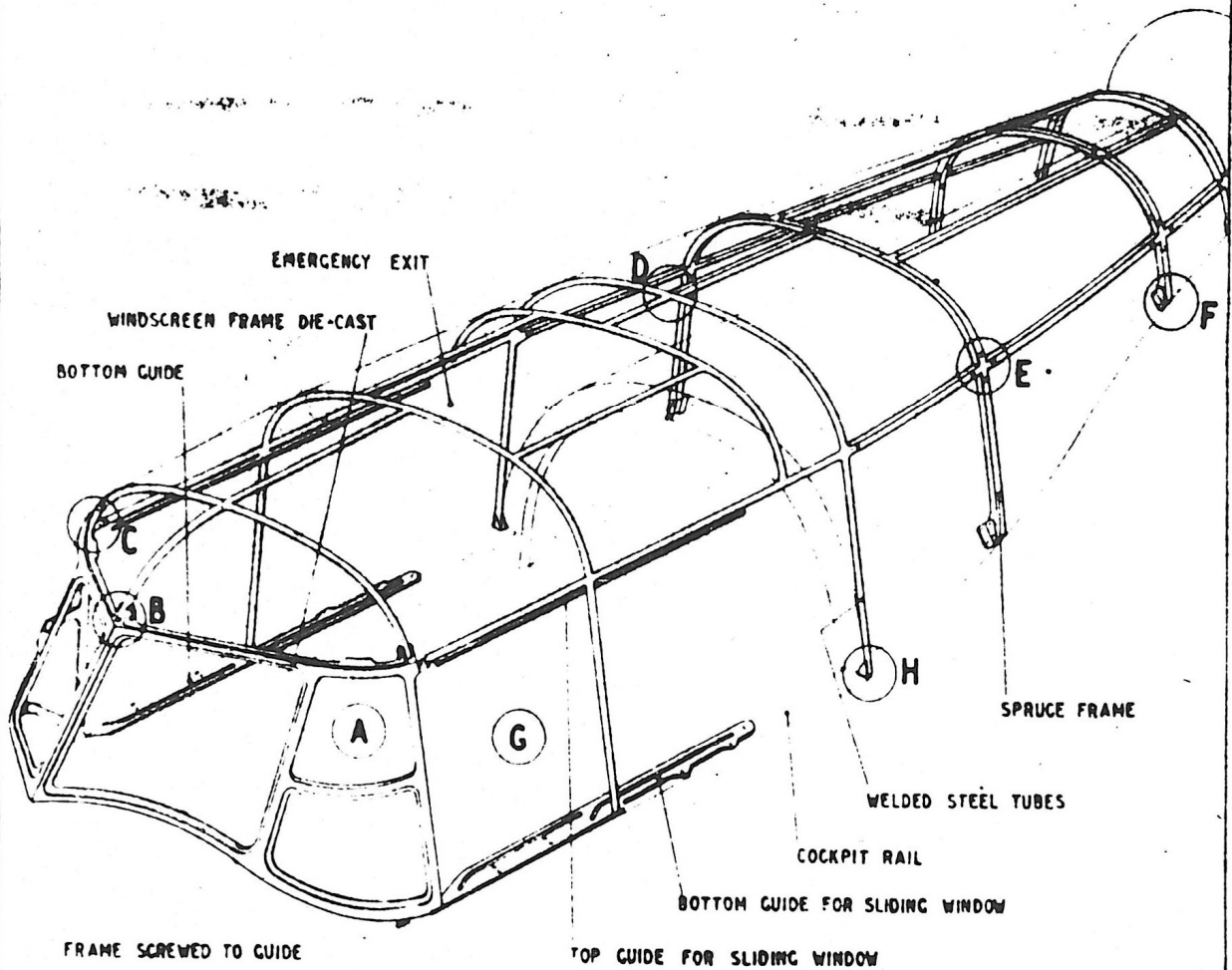

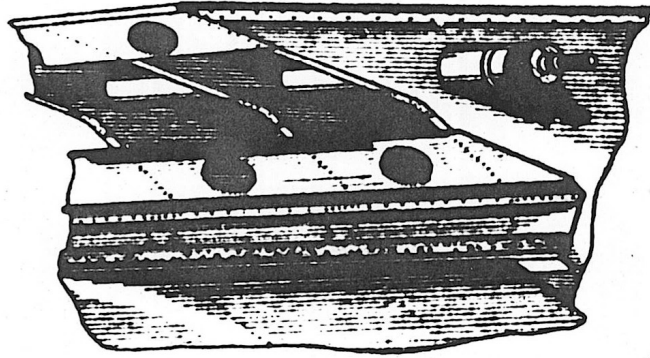

STRUCTURE AT FALSE SPAR  
LESS FLAP

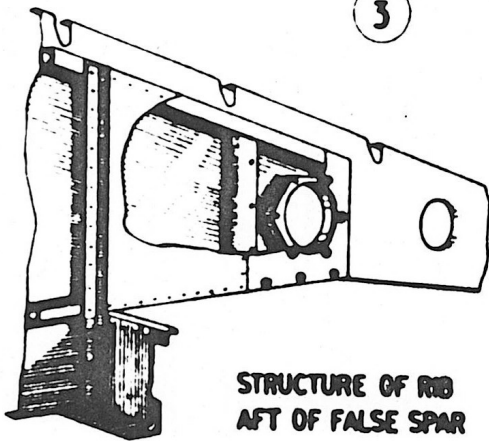
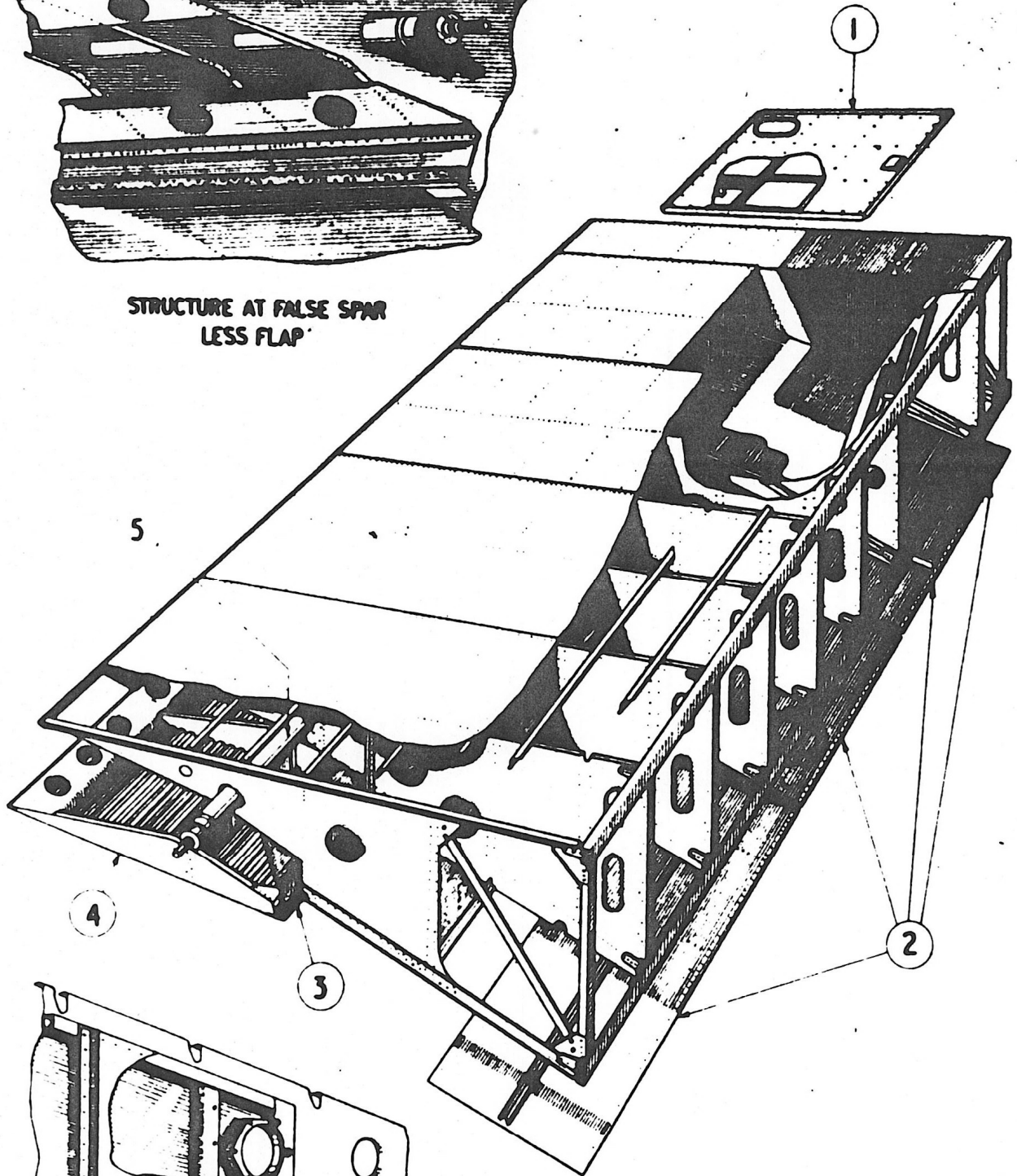

STRUCTURE OF RIB  
AFT OF FALSE SPAR

- 1. DIRTY STORAGE COVER
- 2. ASSEMBLY PANELS.
- 3. FALSE SPAR.
- 4. FLAP
- 5. FLAP OPERATING MECHANISM.

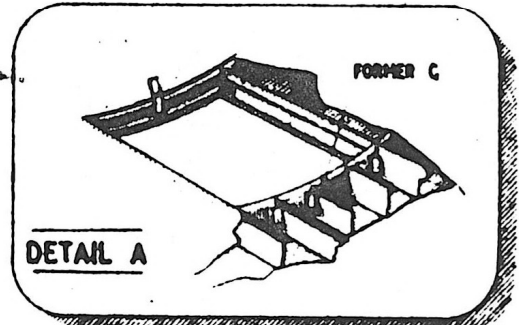
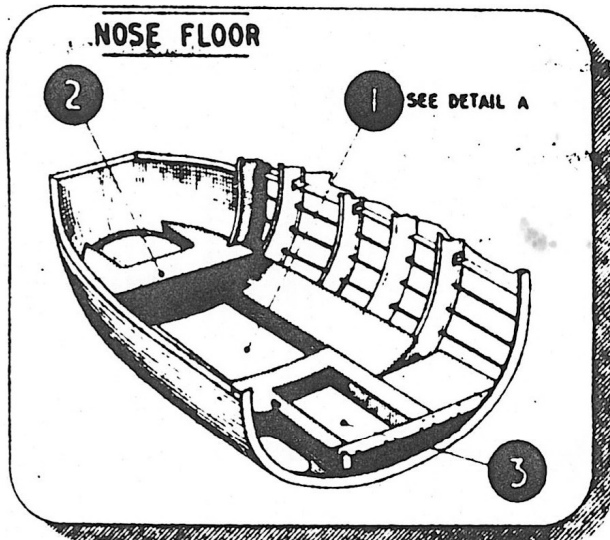

- 1 PARACHUTE EXIT
- 2 AIR-BOMBER'S FLOOR
- 3 LAUNCHING CHUTE OPENING

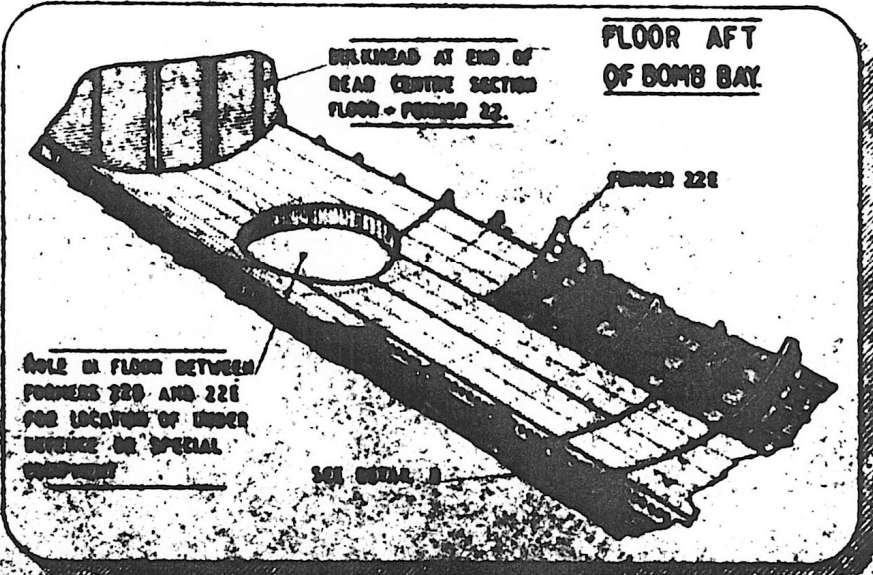
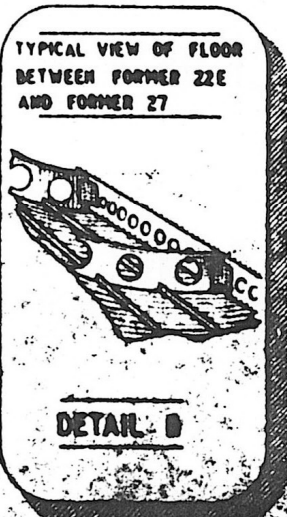
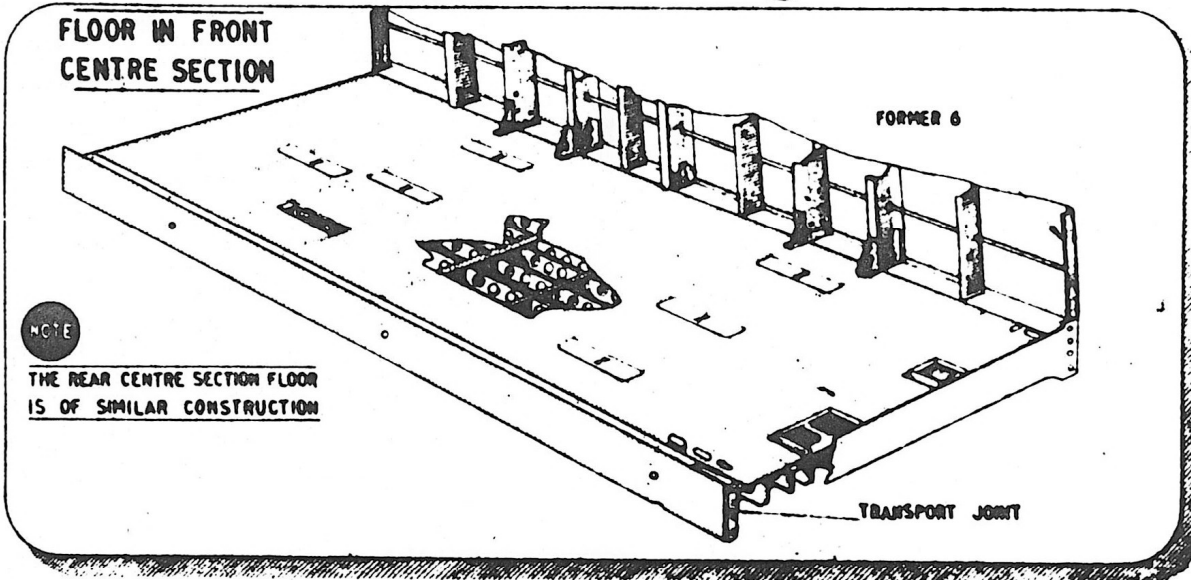

**TEST SPECIFICATION N° 124.**  
**INSULATION TESTS OF ELECTRICAL INSTALLATION IN LINCOLN MK.30.**

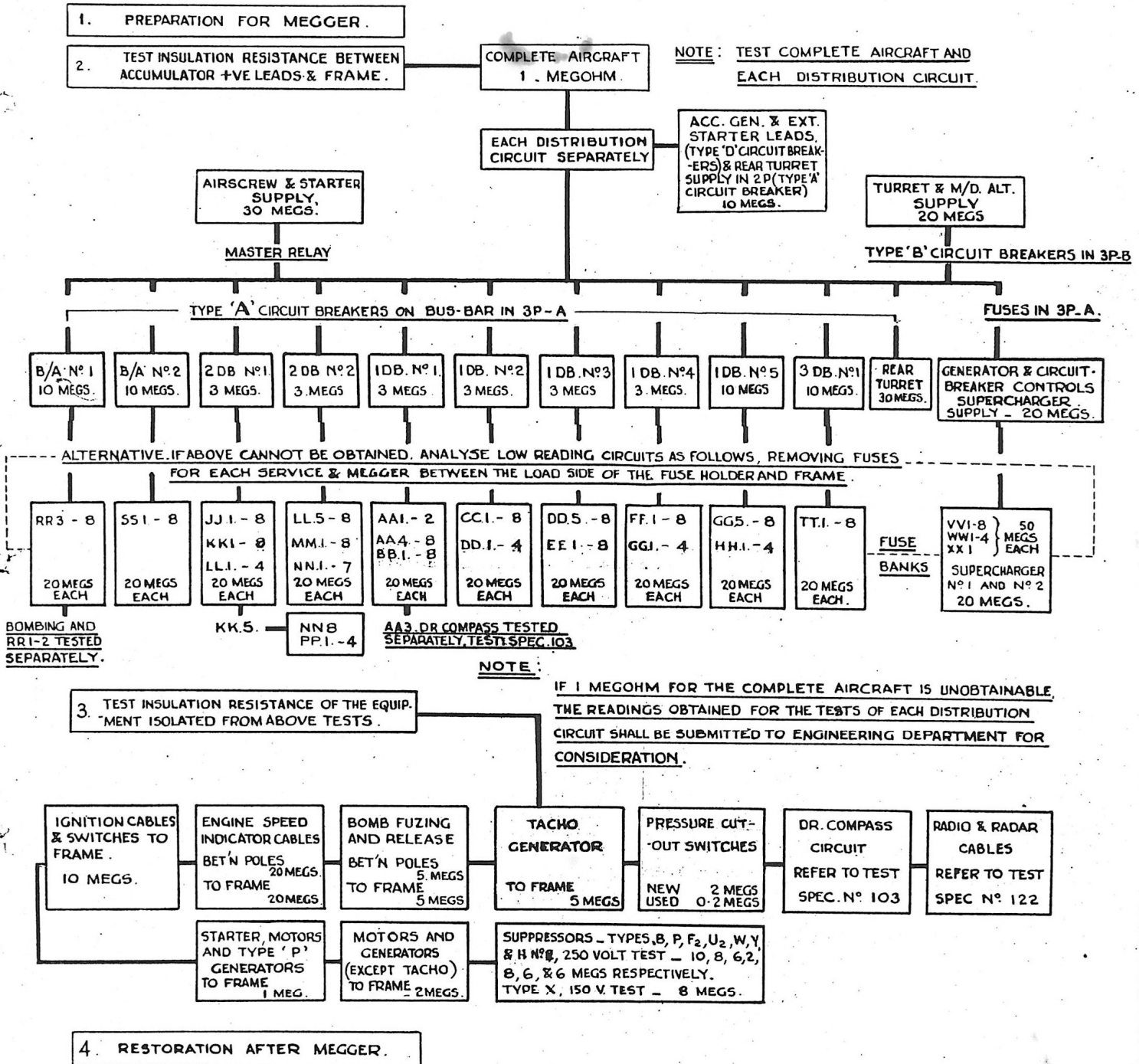

**NOTE**  
 FOR DETAILS OF ABOVE PROCEDURE REFER TO RELEVANT CLAUSES OF THIS TEST SPECIFICATION