



LINCOLN MK. 31

LINCOLN MK 31

Production Details

Serial Number of prototype long-nose Lincoln (G. R. Mk 31) A73-48
Total Number converted to Mk 31 20
Serial Numbers of these A73-48, A73-28, A73-55, A73-56,
A73-57, A73-59, A73-60, A73-61,
A73-62, A73-63, A73-64, A73-65,
A73-66, A73-67, A73-68, A73-69,
A73-70, A73-71, A73-72, A73-73.
Total Number of Mk 31's converted to Maritime Reconnaissance 10
First M. R. (A73-60) delivered to R. A. A. F. on 8th Mar, 1955
Serial Numbers of others A73-55, A73-57, A73-61,) Converted
A73-62, A73-65, A73-66,) by
A73-68) G. A. F
A73-28, A73-67 (converted by R. A. A. F)

Leading Particulars

As for Mk 30 with the following exceptions:-

Length: 84ft. 9½ in.
Weight (empty) 44,900 lb.

General

During 1951, a major redesign to convert 20 Mk 30 Lincolns for general reconnaissance duties, was undertaken by G. A. F. This entailed extending the fuselage 6' 6" to accommodate additional crew members and new equipment for the General Reconnaissance role. These aircraft became Lincoln Mk 31(G. R.) At a later date 10 of these aircraft were fitted with submarine locating equipment and were designated Lincoln Mk 31 Maritime Reconnaissance (M. R.)

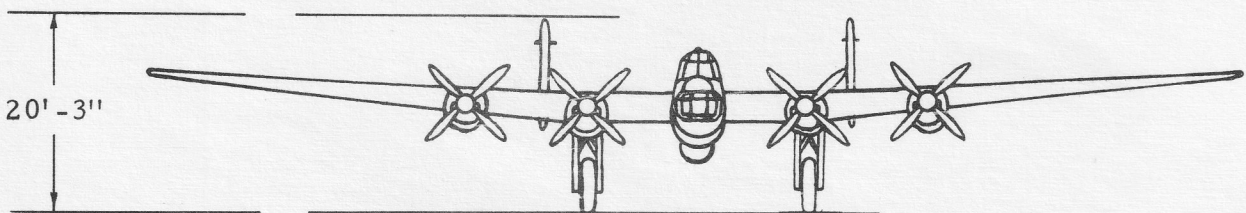
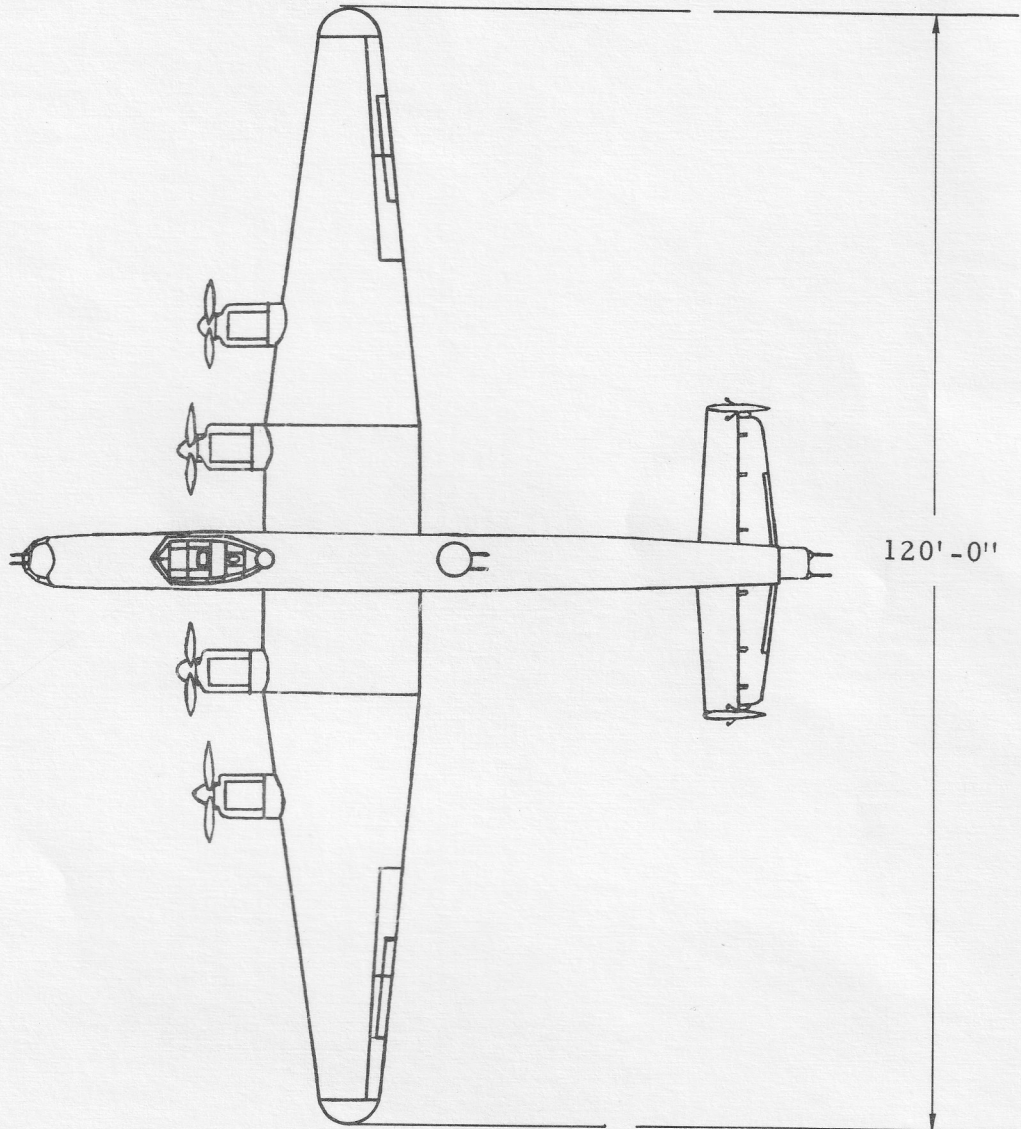
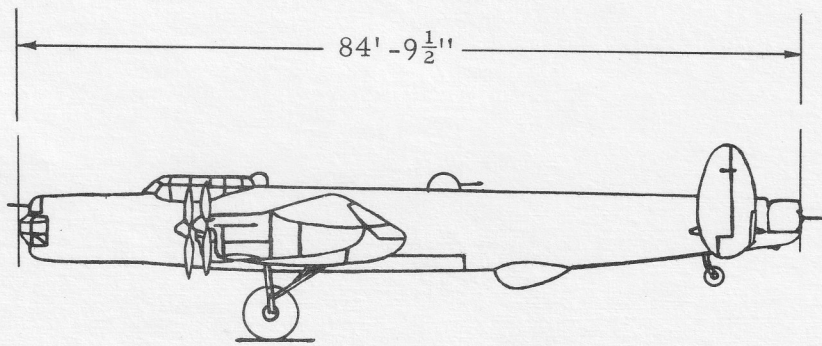

GENERAL ARRANGEMENT - LINCOLN MK 31