

MELBOURNE AND METROPOLITAN TRAMWAYS BOARD

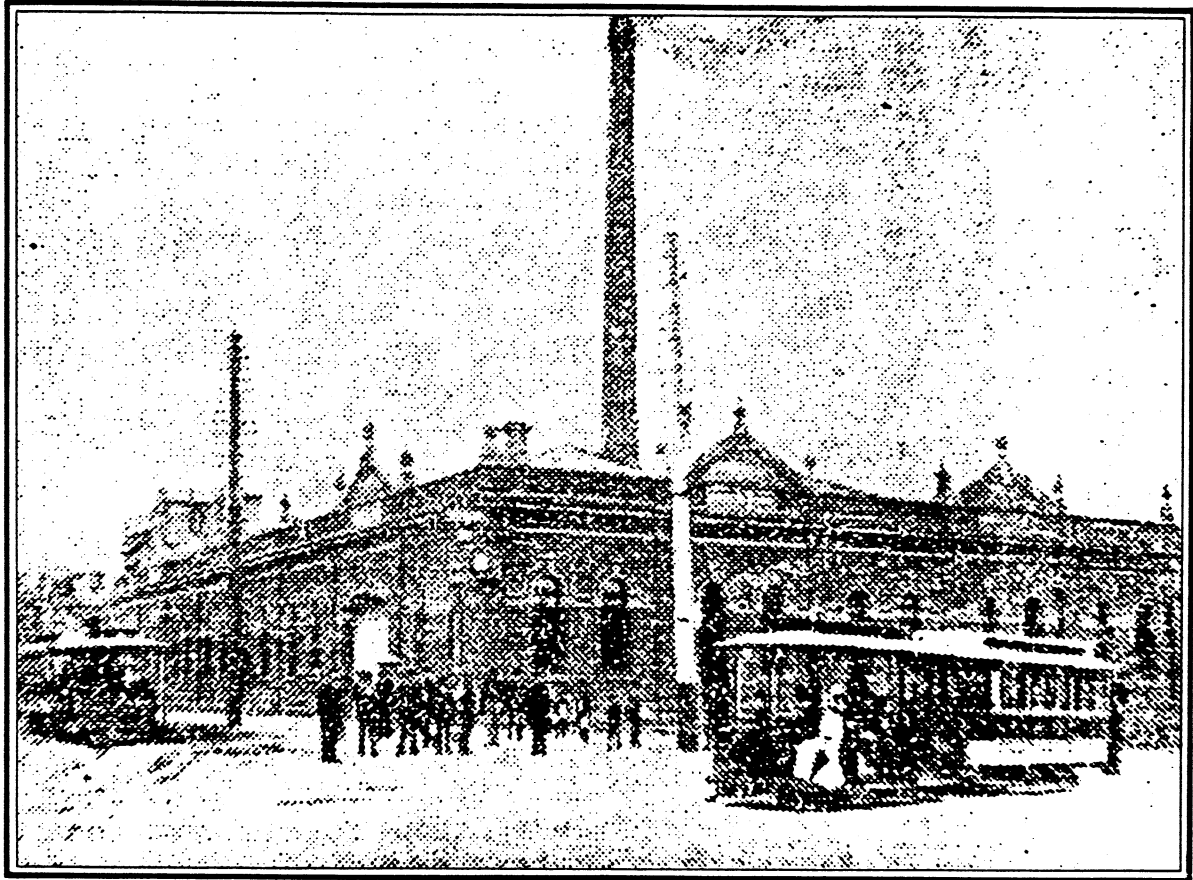

MELBOURNE CABLE TRAMWAYS

DETAILS OF CONSTRUCTION AND OPERATION OF
POWER HOUSES AND TRACK

MELBOURNE CABLE TRAMWAYS.

DETAILS OF CONSTRUCTION AND OPERATION OF
POWER HOUSES AND TRACK.

Compiled by William R. Pollock, A.M.I.M.E.

Assistant Power House Superintendent and
Power House Superintendent with the Melbourne
Tramway and Omnibus Co. Ltd., the Tramway
Board, Melbourne and the Melbourne and
Metropolitan Tramways Board.

THE MELBOURNE CABLE TRAMWAY SYSTEM

POWER

The Melbourne Tramway Cable System consisted of 12
Power Houses operating Cables as under -

Power House	Situation	Opened for Traffic	Power House Closed	Cables	Length in feet	Terminals
Fitzroy	Vic. Pde. and Brunswick Street	2/10/1866	12/7/30	Collins St. Victoria St. Brunswick Street	17000 22700 23000	Spencer St. Vic. St. Bridge St. George's Rd. & Miller St.
Nicholson Street	Gertrude and Nicholson Streets	10/8/1887	26/10/40	Bourke St. Smith St. Nicholson Street	17000 24100 19250	Spencer St. Clifton Hill Park Street
Johnston Street	Johnston St. near Bruns. St.	21/12/1887	15/4/39	City Suburban	16700 14500	Swanston St. Johnston St. Bridge
North Carlton	Rathdown & Park Sts.	5/2/1889	1/8/36	Rathdown St.	13400	Elgin Street
Richmond	Hoddle St. & Bridge Rd.	11/11/1885	30/1/27	City Suburban	25200 14300	Spencer St. near Lonsdale St. River (Bridge Rd.)
Northcote *	High and Martin Sts.	18/2/1890	26/12/40	High St.	25000	Clifton Hill to Dundas Street.
Brunswick	Brunswick Rd. & Black St.	1/10/1887	11/1/36	City Suburban	22700 16750	Victoria St. Moreland Rd.
North Melbourne	Abbotsford & Queensberry Sts.	3/3/1890	29/9/35	City Flemington West Melb.	20000 13000 17600	Flinders & Elizabeth Sts. Flemington Edge. Elizabeth and Lonsdale Sts.
St. Kilda Road	St. Kilda Rd. and Bromley St.	10/10/1888	2/1/26	City Suburban	24150 29990	Queensberry St. Brighton Rd. & Milton Street
Toorak	Toorak Rd. & Chapel Street	26/10/1888	2/10/26	Domain Rd. Toorak Chapel St.	17270 14950 21810	Domain Rd. & St. Kilda Rd. Irving Road Carlisle St.
South Melbourne	City Rd. & Cecil Street	17/6/1890	7/3/37	City Clarendon Port Melb.	10900 22500 17000	Market & Collins Streets Victoria St. & Beaconsfield Pd. Beach & Princes Streets
Wellington Street	Wellington St. opp Marlton Crescent	27/10/1891	30/8/25	Esplanade	21300	Barkly Street

* Northcote cable line was not one of the lines operated by M.T.O. Co. It was laid down by Contractor of N.C.C. and opened for traffic 18/2/90, under lease, closed down 7/7/93 reopened under lease 7/4/94, closed down 7/11/97; reopened March 1901 and taken over by the M.M.T.B. on 7/2/20. The M.T.O. Co. lines taken over from TEMP. Board on 1/11/19. In April 1925 Northcote track was connected to the Clifton Hill track so that, cars ran through from Bourke St. to High St. terminus at Preston.

Power for operating the twelve Power Houses of the Melbourne Cable Tramway system was Steam, generated by Marine type Multitubular Boilers, in ten Power Houses and by Babcock and Wilcox Watertube boilers in the other two, these being Richmond and Fitzroy Power Houses.

The original boilers installed were all operating when the Power Houses closed down. In the case of Richmond Power House they were at work for nearly 42 years, the only renewals being a few tubes in the fire row, a wonderful performance for a water tube, or any other boiler.

The Marine type boilers were all built in Melbourne, each boiler was approximately 7'0" diameter x 15'0" long fitted with Fox's corrugated furnaces, Working Pressure 103 lbs. per square inch, Grate area 18 to 24 square feet, Heating Surface 750 square feet and efficiency from tests varied from 67% to 74%.

Steam was delivered to horizontal engines 24" x 48", at 60 R.P.M. built by Shanks & Co., Scotland, and approximately 800 I.H.P. at Fitzroy, Nicholson Street and Toorak Power Houses, and to 20' x 40' at 72 to 80 R.P.M., approximately 560 I.H.P. at the others. The smaller engines were all made in Melbourne by Hughes, Pipe & Rigby, later the Austral Otis Engineering, and were fitted with Myer Expansion Valves.

The larger engines had cylindrical expansion valves on the back of Main Valve, Ports being diagonal and the expansion varied either by hand or governor by turning the expansion valve.

Towards the close of the system owing to increasing load the 24" cylinders were replaced by ones of 25" diameter at Nicholson Street and Fitzroy Power Houses. At Fitzroy and Brunswick Power Houses the engines were supplemented by a steam auxiliary engine which was connected up for the evening Peak Loading.

At St. Kilda Power House as the loading grew, the engines were supplemented, first, by a steam auxiliary, and, later by an electric motor which when St. Kilda Road closed down was installed at Nicholson Street Power House.

Steam drive was discontinued at the Rathdown Street Power House in October 1919, being replaced by Electric Motor. A small locomotive type boiler was installed to supply steam for the small donkey engine for reeling ropes etc. The engines for this station were transferred to Richmond Power House, 1920, and then formed the principal Power for this station. The original engines at Richmond were very noisy and caused much vibration, being a geared drive, the plant for Rathdown Street being Manilla Rope drive.

The engines in all cases, exhaust into heaters and thence to the atmosphere. The top half of these heaters was fitted with quartz, feed water entering at the top through a rose, meets the exhaust steam entering under the quartz and heats the feed water to approximately 210 degrees Fahrenheit. This hot feed water accounted in a large measure, for the excellent condition of the boilers.

Engines were in duplicate to ensure continuity of operations, either one, as desired was coupled by means of a crank pin, and loose bush to an intermediate shaft on which was mounted wheels about 8'0" diameter to transmit the power, by means of 7" circumference manilla ropes to 24-foot diameter wheels. These wheels were mounted on the shaft that carried the cable drivers (appendix 2).

It is of interest that the first set of manilla driving ropes ran for about 30 years owing to the wheels being large and the design on generous lines.

The cable drivers originally 12' 0" diameter, were increased as

the speed of the Trams was increased, to 14' 0" to give a rope speed of 13½ m.p.h.

The cable drivers (appendix 3) consisted of a cast iron wheel, 14' 0" diameter (in some cases 12' 0" and 13' 0") on rim of which were mounted 2 sets of cast steel jaws. These V jaws, the V 1 in 4, were fitted with wood bottoms, and were in 12 to 14 sections round the wheel.

It was the practice to put a new rope into new steel jaws, the old set then being sent to the Repair Shop to be machined and have new wood fitted.

Originally each rope was taken round two drivers, which were geared together. This proved unsatisfactory as well as noisy, and was discarded. The gear wheels were taken out, and the back driver moved back. When the diameter of the drivers was increased the driver which had been moved back was discarded, and replaced by a light idler.

The incoming cable went round the driver, thence round the idler, thence along the rope race round the tension wheel, and out to the road (appendix 4).

The tension of the rope varied according to the length of rope, particulars of line and conditions, between 2 to 5 tons, and was adjusted when necessary as follows:- A moveable carriage carrying a tension wheel of some 13' 0" diameter round which the cable passed, was free to move on an undercarriage.

The shaft of this wheel was extended to carry a warping drum. The undercarriage was mounted on four wheels, and held in place by four pawls, which engaged with teeth on a rack, extending on both sides of the rope race for the length of the race, attached to the back of this undercarriage was a 3 sheave block, a similar block at the end of the race, a fall either manilla or wire was reeved through these blocks, and used to tighten up the tension when required. The top carriage was attached to the tension bucket, carrying the weights by four chains passing over pulleys, mounted on the back of the undercarriage. This bucket moving up and down in the race as the tension wheel moved to and fro. Two long bolts fitted with volute springs, were attached to the back of the top carriage, and passed through eyes in the back of undercarriage, to keep the movement of top carriage within limits. When this movement became too great, the undercarriage was pulled back in the following manner. The front ends of the two carriages were lashed together. The fall was then put around the warping drum, referred to, engines slowed and strain taken, wedges on back pawls knocked out and tension pulled back as far as required. Pawls wedged, and lashing taken off front ends of carriages, speed resumed, and top carriage free to move again.

FUEL

In the latter years of cable operation Coke, or Coke and breeze was almost the only fuel used, owing to the fact that no other fuel could economically compete with it. Coke in those days had a moisture content of anything up to 30% and this figure was quite frequent. Arrangements between the Company, and later the Board, and the Gas Company, allowed us to deduct from the bill all moisture over 8%.

Samples were taken from each bag delivered by Power House staff, mixed, and 1 lb. sample secured from each load. This was placed in an oven and dried and the loss measured in grains, dividing this loss by 70 gave the percentage of moisture. This was done by Engine Driver on shift and returns sent to the office, checked, and a copy forwarded to Gas Company. As stated all over 8% was deducted from the account.

Fuel and water tests were carried out at frequent intervals, and always if some fuel other than coke was offered.

Indicator Cards for Ropes, and Machinery, and special traffic, were also taken at frequent intervals.

Fuel and water tests were run for 1 week, in which special men weighed all the fuel and water used.

Indicator Cards were taken at half-hourly periods during one day (of 18 hours), and at ten minute intervals during Peak Periods. The number of trams on rope at these periods were ascertained from District Traffic Superintendent. (Appendix 5).

The basic fuel was coke and breeze, but the M.T.O. Co., and the Board, have used every type of fuel offering, including Tar, Wood, all sorts of Coal, large and small, good and bad, and Briquettes, depending on the price. Any new fuel offering was immediately subjected to a test as described, and a similar test run with coke, and breeze. If the price was right an order was placed, and the fuel used just as long as the price remained favourable. It is safe to say that the M.T.O. Co., knew more about the relative values of all fuels both N.S.W. and Victorian than anyone.

Merely as an instance in November, 1933, we tested at South Melbourne Maitland Coal (nuts), Northern Mait. Coal (Slack), and Coke and Breeze, as supplied to us by Gas Co. The offers were:-

Maitland nuts 26/6 ton
Northern Main Slack 25/- ton and,
Coke and Breeze 24/6 (average price paid by us to Gas Co.)

On test we found that the costs of evaporating 1,000 galls. of S. & A. were:-

Coke and Breeze 13/5.
Maitland 14/3.
Northern Mait. 14/4.

or, in other words with Coke and Breeze at 24/6 Ton, Maitland was worth to us 22/7 ton, and Northern Mait. 21/2 Ton.

In July, 1893, Tar was offered to the M.T.O. for 5/- per 100 gallons delivered. This was too good to miss, so Messrs. Turnbull and Dahn, evolved a burner (appendix 7) which after a few teething troubles, burnt successfully nearly 2,000,000 gallons of Tar. Tar as a fuel was burnt, exclusively at Johnston Street, Nicholson Street, and Fitzroy Power Houses, and partly at South Melbourne Power House, until December, 1900, when owing to its use for other purposes, the price was increased, and its use discontinued.

The Tar was delivered from the Gas works and emptied into tanks at Power Houses, pumped into an overhead tank fitted with a heating coil, it then gravitated through filters to the furnace. Furnaces were lined with fire-brick, and air admitted towards the back of the furnace. No alterations were made to the furnace fronts which were the usual ones as fitted for coal or coke burning.

In the 1920's we were for a time unable to dispose of all our Tar Oil, a by-product of our Tar distillation plant, so one of the original burners was fitted up to a Babcock and Wilcox boiler at Fitzroy Power House, and the tar oil burnt quite successfully.

The Horse Power required for the ropes and machinery varied with the different lines, a straight line such as Sydney Road taking less than a line with a number of curves, it also varied with time rope had been in use, a new rope taking more power to run than an old one.

I.H.P. for this purpose will run from 100 to 190 I.H.P. the average being about 175 I.H.P.

The I.H.P. per tram varied considerably with weather conditions, being between 10 to 13 I.H.P. per tram including ropes and machinery and from 7 to 9 I.H.P. excluding ropes and machinery.

In 1918 at St. Kilda Road Power House, average I.H.P. over traffic hours was 411 I.H.P. with a maximum of 683 I.H.P. (auxiliary engine coupled up for evening Peak) during the evening Peak.

The instantaneous variation of load on cable system varies very considerably. With the Steam Engine and Manilla Rope drive these variations were not noticed to any extent, the engine merely slowing up momentarily.

Towards the close of cable operation the load on St. Kilda Road became so great that an electric motor was installed to run in conjunction with the steam plant. This motor was run at first as a self synchronising motor of absolutely constant speed.

During Peak hours with the engine giving out say 580 I.H.P. we frequently got readings on the meter of 700 h.p. or a total of 1280 h.p. Needless to say the gearing would not stand up to this. The motor was then worked as an ordinary induction motor, the slip obtained by this means gave a much smoother operation with no further trouble from the gearing.

PERMANENT WAY.

The Permanent Way of Cable System, consisted of approximately 46.8 route miles of track. Grooved rails of weight 57, 67 or 87 lb. per yard, depth respectively 5", 5½" 6½". The 57 lbs rails were laid in St. Kilda Esplanade only; the 87 lb. rails laid in Port Melbourne and City, not including Market and Swanston Street, the balance of the track being 67 lb. rail. Gauge of track, 4' 8½" and tracks 9' 0" centres. The rails were laid on 6" of concrete and the tunnel constructed of concrete, was 18" inside at widest part and 3' 8½" deep from roadway to invert of tunnel.

Embedded in the concrete forming the tunnel were yokes made of 'T' head rail suitably bent, which carried the slot beams to form the slot for the grip and, also, at half chain intervals, the cast iron yokes to carry the line pulleys and drums for supporting the cable. (Appendix 6).

Manholes were set at every half chain to allow attention to be given to the pulleys and drums.

Grip Hatches, which were of cast iron, were placed at suitable sites to allow grips to be put in or removed from the tunnel.

The construction was such that the rope ran 1½" off centre to the tunnel at a depth of 2' 1½" from the roadway.

The slot beams were bolted to the yokes to give a ½" slot; rails just lay on the concrete bed, and tie rods were inserted between slot and rail, and between rails in the clearway. Pavement was wood blocks throughout, some 20,500,000 (twenty million, five hundred thousand) blocks in all being required.

Curves on the system were arcs of a circle, there being no transition.

Shunting at termini was arranged in various ways, depending on grade of road. Where grade was suitable it was unnecessary for the gripman to leave his dummy or the conductor the car. At other termini the dummy would fly through automatically, pick up rope and set slot tongue, the points being operated by weights, and come back on other track, car pushed through and then dummy pushed back on to car.

There were various arrangements. Quite often there would be a car shunt as well as a dummy shunt.

As an instance of the speed with which trams could be shunted we put through 10 trams in 6 minutes, that is one tram in 36 seconds, on the occasion of the visit of the Prince of Wales on 26/5/1920 at the shunt in St. Kilda Road near Burns Statue (Sturt Street).

At this shunt the dummy shunt was facing and the car shunt trailing. Dummy flew through the dummy shunt, hand pick up used to put rope in grip on 'down' track and points operated by rubber insert and the slot tongue operated by grip by means of a kicker across the slot. Car was pushed through the car shunt and coupled to dummy which had meanwhile moved forward to a suitable position. Dummy points and slot tongue on 'up' track were locked set for the curve. When not in use this shunt was, of course, locked for the straight track. Plenty of men were available and no waiting for cars so that tram crew did not have to leave the dummy or car at all, as junction, points and slot tongue were worked by hand.

It was the usual practice to have them set for the curve and altered for the straight track.

Conductors on both routes had to leave their trams and do something, the one on the straight track to shift the points and the one going round the curve, to pick up rope which gripman would previously have thrown. When either failed we would get damage to the rope.

The slot had to be maintained at 7/8". We were greatly troubled in some places by tight slot, that is, the wood blocks would squeeze the track until the slot was too narrow for the grip to pass. In some cases grips would be caught in the slot and traffic held up until the pressure could be relieved.

Generally by keeping a close eye on it and knowing the danger spots we were able to take suitable action in time to prevent a stoppage.

White marble blocks let into the roadway for an equal width to right and left of the slot indicated that certain things must be done at the instant when the front of the dummy reached them, as follows:-

Three rows	...	throw rope
Two "	...	pick up rope
One row	...	stop
One row followed by three rows	...	stop and then throw rope
One row followed by two rows	...	stop and pick up rope
Three rows followed by a diagonal row	...	throw rope and close grip at once.

In the vicinity of junctions etc. marble blocks to right or left of the slot only, indicated that they referred only to the tram taking the right or left track.

The rails in a cable system last a long time, some of the original rails being still in the road when the lines closed. One such line was Richmond suburban section. The rails in this section had been planed, that is, had the groove deepened and lip cut down and when taken out of the road in January 1927 the head had in many instances been practically worn off so that trams were virtually running on the fillet. In a cable system the wheels are rollers and not drivers - this, of course, makes less wear on the rails.

The trams themselves were moreover of light construction, the weights being:

Dummy	54 cwt.	length 16'8"	overall,	licensed to carry 20
Standard car	49 "	"	22'0"	" " " " 34
Bogie car	88 "	"	30'0"	" " " " 46

The wheels of both Dummy were of Cast Iron, Cast in a chill.

The tracks were top-dressed with distilled tar each year, the tar being distilled by the Company and later by the Board, from crude tar pumped from the Gas Works to distilling plant situated in Flinders Street Extension adjacent to Gas Works. Average results for 1915-1916, 1916-1917 were:

Boiled tar, per sq. yd. of double track	...	0.195 Galls.
Sand per chain	" " "	... 0.45 cub. Yds.
Man hours per chain	" " "	... 4.35 hours.

Switches and mates were made of cast steel and weighed with fish plates approximately 3 cwt. 3 qrs. each and all were standard at either 70 ft. or 90 ft. radius. Originally in places where the rope was automatically picked up a deviation was put in the track to enable the grip to pass the wheel elevating the rope. These deviations were all taken out and straight rails put through, a special narrow elevating wheel (appendix 10) put in the slot slightly sprung. This arrangement was just as effective and greatly reduced wear on rails and slot at this point.

CABLES.

When Cable Tramway was first opened in 1885, ropes were of 3-5/8" circum. and 11" lay and consisted of 7, 15, or 19 wires each. The 19 strand ropes were made by Roebling, U.S.A., of ordinary construction, all other makes were Lange lay made in England.

Over the years, and owing to increase in Traffic, the size of the ropes was increased until it became standard at 4" full circumference, 10" lay (Langs lay) 7 wire construction. Just before St. Kilda Road Power House was closed, ropes of 4-1/4" circumference and 15 wire construction were being used in the city section, but were not in operation long enough to determine whether they were an improvement on the 7 wire construction.

Ropes were made from what was known as "Special Acid Steel" of highest quality procurable, having a large admixture of best Swedish material. The construction - 6 strands of 7 wires over a medium hard laid up manilla core. The strands of the rope were of 1 3/8" circumference, 4 1/2" lay, 6 wires of .142" dia. over a soft iron core .144 dia.-rope core of manilla, usually about 2" circum. and 2" lay-weight of rope approximately 2.6 lbs. per ft.

The lengths of ropes varied from 17,000 ft. to 30,000 ft. the latter weighting approximately 35 tons. Breaking strain 66 to 68 tons per sq. in. We found from experience that if we got a rope of from 66 - 67 tons, we got a better rope for our purposes, than one from 69 - 70 tons breaking stress. It was apparently difficult for makers to keep down the tensile strength and still maintain the quality of the wire.

All wires in the rope were either brazed or welded, so that the wire was in one continuous piece for the length of the rope.

A rope was unloaded from the ship, hand over hand, and coiled on to pairs of lorries, up to 5 pairs being necessary in some cases. The rope was then carted to Power House, and, either coiled down in a trough or reeled up ready for putting in the road.

To put a rope in the road, after traffic is over and engines stopped the tension is eased to a degree just sufficient to keep rope on sheaves and pulleys, then clamps put on. The rope is then cut and new rope roughly spliced to old rope, the other end of old rope is attached to a reel operated by a small donkey engine, clamps taken off and Power House engines run slowly, pulling new rope into the road against a brake, the incoming end of old rope being reeled up by the donkey engine.

When new rope is all in road outgoing clamp is put on, rope tightened and incoming clamp put on, ends are spliced, tension taken up and clamps taken off and road inspected to see that new rope is on all pulleys and sheaves.

The weight in tension bracket varies from 2 to 5 tons according to conditions of particular road and length of rope.

Speed of ropes, originally about 8 m.p.h. increased over the years, till nearly all were either 12-1/2 or 13-1/2 m.p.h. Two sections only remaining at 11 m.p.h.

Rope is carried in the tunnels on pulleys set every half chain, and around curves either on pulleys or drums about 2 ft. dia. set round the curve, or by means of a 12' 0" dia. sheave suitably positioned.

There is an oblong figure on a blackboard (appendix 21) in a suitable position in Power House marked off into the No. of revs. it takes splice in the rope to make a complete circuit, this splice is known as No. 1 splice, this figure virtually becomes a drawing of the rope, as every defect, broken wires, strand, splice, kink or weak place, is marked thereon as so many revs. from No. 1 splice, the Ropeman can, by this means, tell when any of these places will come into the Power House and act accordingly.

When a new rope was run into the road, it was filled with a composition known as "Rope Filling" to keep the water out and when the rope is filled (after about 3 weeks), it is regularly lubricated with rope oil once or twice per day, occasionally more often. Rope filling must be liquid enough to run into the innermost spaces between the strands, it must set and when set remain plastic enough, so that it will not crack and fall out when the rope is being bent round curves etc., it must be waterproof and of a lubricating nature. Keeping the water out of a rope is an important factor on its life.

The rope filling consisted of a mixture of Stockholm Tar Sludge Oil and plumbag approx. 3: 2: 1/2. The mixture was boiled in a copper by Power House staff and applied to the rope warm. A container at floor level fitted with cock and pipe leading down to out-going rope held the "filler" and filling was permitted to trickle on to the outgoing rope 3 or 4 times a day till rope was filled. Rope oil was then applied when required, generally once or twice daily.

The practice was to use new ropes in city and important sections and then take them out before they were worn out and put them in suburban and less important sections; this resulted in a longer average life and less risk of stoppages due to rope trouble.

Two factors operate against the life of a rope, wear by the grips, and curves. Grips wear the wires and make them thin in the crown, and curves by alternate bending and straightening break the wires. By far the more potent factor is the curves. The majority of ropes were discarded through broken wires and not because they were worn in the sense that the grip wears the rope down.

Safety Devices - Strand Alarm - (Appendix 22)

Situated in the Power House pit, on the incoming rope, was a device known as a "strand alarm". Should there be a protruding wire or broken strand on the rope, it would strike this device which then made an electrical contact and rang an alarm in the Power House giving the engine driver time to slow down the engines and the ropeman time to examine the rope. Quite often, this alarm was rung by pieces of rag etc. which small boys used to delight in dangling down the slot until they were caught by the rope.

Stop Bar

This is a bar some 3" dia. placed in the tunnel in such a position that the rope passes on the opposite side of it to the grip.

This bar is to protect some special underground gear in the event of a gripman failing to throw the rope at some place where it is indicated he should do so and is the lesser of two evils.

When a rope is overcarried in this manner, it is kinked more or less and can be cut in two - more or less damage being done to the grip. (Appendix 20).

If only slightly kinked, no stoppage would occur, the rope merely being slowed up to enable the ropeman to view the damage, when more severely damaged, stoppage may be anything up to an hour. If a strand is cut out and bunched, stoppages may be up to 4 hours.

When a gripman fails to throw the rope or was late throwing it, he was supposed to notify Power House on the alarm signals, when all would be on the alert for the damaged piece to come into Power House. This was not always done and cases have occurred when the first indication to Power House was the 5 strand piece coming in. A bunched strand (appendix 19) if of any magnitude usually broke some of the C.1 yokes carrying the line pulleys and always displaced the line pulley drum etc.

Alarm Signal.

Signal boxes were placed all round the road at selected places and had inside a dial with such notations as Stop rope, Start rope, Run slow, Track blocked, Fire hose across track, grips broken and wedged, send help etc. and a Pointer. A member of the tram crew went to the box, set the pointer and depressed a trigger. This sent a signal to Power House, which was recorded on a telegraphic tape and indicated the message and also the station from which it was sent. For a stop signal it was only necessary to depress the trigger, without bothering to set the pointer. By means of a Pocket Telephone from any of these signal boxes the Power House could be spoken to. There was a "Throw Rope" Mark in Gisborne Street opposite the Fire Brigade where the Collins Street rope had to be thrown and the auxiliary picked up. As this "Throw" Mark was away from any junction crossing or Power House and was liable to be overlooked by the gripman a warning gong was placed in the tunnel. The grip moved a "Kicker" across the slot which operated a striker which struck the gong thus warning the gripman to be on the alert.

Varieties of kinks and strands were endless and it is safe to say no two were exactly alike, nor was the method of dealing with any two exactly the same - hence the necessity of someone of experience and authority being quickly on the spot. The worst case is when a strand is bunched and the rope parts. When this occurs, the facing end flies back in the tunnel and as the trams are moving forward, loops form round the first few grips. All these loops have to be freed from round the grip and slack got up in the roadway before anything can be done towards pulling the ends together preparatory to splicing. The difficulty will be appreciated when it is understood that there is a manhole only every 1/2 chain and the tunnel is not big enough for an average man to crawl through.

There are various methods of dealing with bunched strands etc. depending on the particular circumstances of the case - among which are -

1. The bunched strand may be got up on road and cut off,
2. or taken to a pit and cut off there
3. The rope may be cut - bunch taken off - and rope spliced.
4. The rope may be cut at each end of bunch and a piece put in.

Splice usually put in a new rope is approximately 80 ft. long, (appendix 24) and in a new rope it is most difficult even for experienced men to find the splice for a few days until the rope is filled and some wear showing on the wires.

To make a finished splice for traffic purposes, takes seven men about 2 hours.

The record time for a splice was 23³ minutes. This time was from stop of engines to start of engines, and included putting on clamps, slackening tension, making splice, taking up tension and taking off clamps. This occurred when it was found necessary to shorten a rope during traffic hours, and as stated, the traffic was only held up 23 minutes. Plenty of men were available and were organised by the late Mr. James Turnbull, who with W.R.P. supervised the work.

Very complete records are kept of every rope and are known as rope histories - these histories record all the events in the life of the rope and are a tribute to the late Mr. J.W. Duncan (appendix 23).

Ropes were all made in England, principal makers - Bullivants, Smith, Whitecross, Wright, Newall and Craddock.

Auxiliary ropes were used in short lengths to pull cars round some junctions etc. Where there was rapid wear, these were cut quickly, but the life of the main rope was considerably lengthened by not having to do this duty. Such places were - Junction of Brunswick Street, and Victoria Parade, Junction of Nicholson, and Gertrude Streets, and in Lonsdale Street between Russell and Swanston Streets. The latter was interesting as this auxiliary was driven from a driver bolted to Carlton terminal sheave and there was a tension weight attached to the auxiliary terminal sheave working in a pit in Swanston Street. Trams coasted on the up track and only used the auxiliary on the down track.

To splice the cable - each end is unlaid for approximately 40 feet and hemp core cut off leaving about a foot. Every alternate strand (3 in each end) is cut off leaving about 1 foot. The ends of the rope are then married, that is, brought together so that a long strand from one end of the rope is alongside a short strand from the other end, and so on for all the strands. The ends of the rope are then pulled together until the lay of each end of the rope matches. A short strand from one end is then unlaid and the corresponding long end laid into the vacant space. This strand is run out to the end and the two strands crossed, leaving about 4'6" ends. While this is being done, another ropeman would be running out a strand in a similar manner at the other end of splice.

While these ends were being run out, they would be hammered into place with copper mallets. The other four strands (2 each end) would be run out. Similarly the second, each end, would be stopped and crossed 9 feet in from the first one run out. The third strand would probably be just run about 5 feet each end. This would leave a space between 2nd and 3rd tucks and 4 and 5th tuck. This space is left for running repairing strand into, if necessary, during the life of the rope (appendix 24).

The ends referred to are then parcelled up with hessian to make them larger in dia. but still less than dia. of hemp core. The twist is taken out of the strand at point of crossing; strand flattened and crossed and the end run into the centre of the rope, the rope meantime having been opened and hemp core cut, end pulled out between strands of rope. As end of strand is run into centre of rope, original hemp core is taken out with the result that the rope at this place has a steel core. This is called a tuck and is done for each strand. The finished splice should be indistinguishable from the rest of the rope.

UNDERGROUND GEAR.

The rope was led from, and returned to, the Power House round a series of cast iron sheaves 12' in diameter. These sheaves were housed in large pits, approximately 6' deep, under the track, all could be reached from the Power House by means of passages or tunnels.

The rope went round the curves by means of a series of pulleys and drums (appendix 11A) set at intervals round the curve the grip being prevented from striking these by means of a rubbing bar. This bar was an angle iron set round the curve under the slot at such a height that the back guard or top die holder, as the case may be, of the grip bore on this angle. The curve pulleys were set at a distance from the road equal to the distance of rope when carried in grip.

Later, in many cases these curve pulleys were removed and the rope taken round a 12' sheave housed in a pit under the road set so that the rope left each end of curve at the tangent, being carried in a subway to the sheave.

This greatly increased the life of the ropes.

The trams in such cases went round the curve by momentum, gripmen having to throw the rope before entering the curve and pick it up again (automatically) after leaving the curve.

On up grades, or where traffic was heavy, if for any reason trams could not go round by momentum, the curve pulleys were retained.

Curve pulleys were set with the throat at some distance from road as the opening of the grip, i.e. $17\frac{1}{4}$ ". In the straight track the rope ran at a distance of $2'1\frac{1}{2}"$ from the road. To bridge this gap drums replaced pulleys at the tangent and one or two following. In places where a grip had to cross the rope entering or leaving a curve and there was any likelihood of the rope rising, a conical drum (appendix 12) was placed, this ensured that the rope was kept below the bottom of the grip.

We had designs for 32 different drums, pulleys etc. of these 17 were in general use the balance being special pulleys or drums for a specific purpose and rarely used.

A "Crown" pulley 2'6" diameter on a 2" spindle was, as its name implies, used on the crown of a hill to take the added weight of rope at such a position (appendix 26).

At Termini the rope went round a 12 ft. sheave. To bring it into alignment with the slot (9'0" crs.) a 6'0" dia. sheave was used to deflect the rope.

All pulleys were of cast steel, the harder the better, roughly ground on the throat. Ordinary line pulleys had a $\frac{1}{4}$ " spindle pressed in. In places where the rope was thrown, line drums replaced the pulleys. These drums were bored for an $1\frac{1}{4}$ " spindle with 1" ends and secured with set bolts so that they could be set to the most suitable place on the spindle to catch the rope when thrown out of the grip.

In places where two ropes ran in the tunnel and it was necessary to separate them conical line drums (appendix 13) were used.

The line pulleys were carried by cast iron yokes, (appendix 14) attached to the main yokes carrying the slot beam at every half-chain. The line drums were carried by cast iron brackets bolted to the main yokes. The bearings for these drums and pulleys were merely a cast iron block slipped into a light cast iron grease box. No machining at all except to bore a hole through the side of the grease box to take the spindle (appendix 15).

At Rectangular Crossings, trams on one route carried the rope through, and on the other it was necessary for trams to throw the rope and cross by momentum and to pick up the rope on the other side, this rope would pass under a depression pulley to make certain that it could not be struck by passing grips from the other route. The rope would pass from this depression pulley on to an elevating wheel which would elevate the rope so that it would run into the open grip to allow the gripman to close his grip and proceed.

There would be a "stop bar" (a bar some 3" in diameter) placed in the tunnel at some distance from the "Throw" mark to protect the depression pulleys.

The rope passed on the opposite side of the bar to the grip and should the gripman fail to throw the rope, he would carry the rope round the bar, which thus prevented it from being taken off the depression pulley but caused more or less damage to the rope and grip. In such cases it was helpful if the grip broke.

As mentioned in Track notes, the elevating wheel was a narrow wheel, one edge of wheel being machined off level with edge of rope and protected by a shield plate (appendix 10).

Points and slot tongue were operated automatically or by hand according to circumstances. Automatic operation was effected by the grips moving a "Kicker" situated in the slot which through a system of levers and cranks moved the points and slot tongue (appendix 16). In hand operation a lever at the side of the track was lifted and this through a system of levers operated the points and slot tongue. (Appendix 17).

The rope as already stated could be automatically picked up but in a number of cases the operation of putting the rope in the grip had to be performed by hand (appendix 18). A wire at the side of the track was pulled up, this operated through suitable levers a cone pulley which lifted the rope and threw it into the open grip.

The rope could also be thrown into the grip by means of a hook, which all dummies carried for the purpose, this required strength and knack on the part of the gripmen.

The tunnels of certain lines were subject to flooding in heavy rain, and South Melbourne (City and Port Melbourne) lines were affected by high tides and west winds. Under such conditions in Queens Bridge Street and City Road the water would quite often be over the rope and at times within a few inches of the roadway. When this occurred which it did all too frequently, the road would have to be re-greased as soon as the water subsided.

There have been times when these conditions were added to by heavy rain. At such times water has been to within a foot of the Power House floor at South Melbourne. All low lying pits and tunnels would be flooded, drivers, tension wheels, 12' sheaves, etc. would all be running in or under water with the result that the engines ran slow until the water could be pumped out. There were two pumps for this purpose at South Melbourne Power House.

Some other pits were difficult or impossible to drain; these were fitted with a pump operated from an eccentric bolted on to the angle or terminal sheave, the connecting rod being dropped over a pin from the roadway, when it was necessary to pump out the pit, one such pit was situated at Bay and Beach Streets, Port Melbourne.

At times when the rope stranded and bunched (appendix 19) it would tear out numbers of the cast iron yokes carrying the line pulleys. Substantial wooden frames were kept at Power Houses to drop into the tunnel to carry temporary pulleys until such time as the yokes could be replaced.

These yokes differed slightly from the original ones, they were made in two pieces bolted together and were not bolted to the main tunnel yokes but had fork ends which dropped over the head of the yoke. Ends of varying length were kept in stock to meet all circumstances.

THE GRIP.

A sketch of the grip is given in Appendix 25. There are several interesting features about the grip.

The method of getting rid of the rope was ingenious. The top die holder had a small extension each end which when the grip was opened engaged with a small kicker lever which operated the cones which threw the rope out of the grip. The top die holder continuing up the kicker slid off these extensions and the cones fell back into place. Thus when the gripman threw down his lever to throw the rope, the grip was ready to pick up the rope again without any further action by the gripman.

In front and behind the grip attached to the check plate by clips were what was known as protection pieces. These were of cast steel and made slightly thicker than the check plates, in way of the slot. In the event of Tight Slot these pieces would feel the pressure first and if caught in the slot allowed the grip still to be worked.

Quite often we were able to get a dummy out of Tight Slot by taking a very firm hold of the rope.

On the quadrant there are 18 notches to engage with the Pawl of the grip, ahead of these notches was another called the safety notch. The grip pawl had to be in this notch when the tram was stopped, as with the grip lever in this position there was ample room for the rope to run freely through the grip dies without being able to fall out.

The grip dies were adjustable by means of a screw thread and small wheel to cater for varying sizes of rope.

A safety device was the pawl latch which in case the pawl handle, rod, or pins broke enabled the gripman to release the pawl by pressing on the latch with his foot.

With a pressure of 60 lbs. on handle of grip lever, grip on 1st. notch exerted a pressure on rope of 2040 lbs.

on 9th	"	"	"	"	"	"	"	4560	"
on 13th	"	"	"	"	"	"	"	9120	"

The grip dies were made of a soft iron and were dovetailed in and very easily replaced when worn, in fact they were sometimes pulled out by the rope when a gripman was late throwing the rope. The weight of the rope was carried on a sheave at each end of the grip when running freely through the grip.

If in the event of a derailment or other accident, if the grip broke not much trouble was caused as the tram could be moved away and then portion of grip in tunnel carried by hooks to a grip hatch on a suitable manhole, and lifted out. If the grip bent which was usually the case, by derailing the dummy so that the grip could be moved in the slot, it was sometimes possible to reach a grip hatch and lift grip out. Generally the grip had to be cut out. This was not so difficult as it sounds for we only had to take off the grip links and remove the slide pin, cut the correct bolts and the grip would slip into the tunnel, where it could be carried to a grip hatch and taken out.

APPENDICES

1. Costs of Construction M.T.O. CO. *
 2. Typical Power House layout.
 3. Section of Cable Driver.
 4. Layout of Rope Drive.
 5. Fuel & Water test sheet.
 6. Section of Cable Track.
 7. Tar Burner.
 8. Yoke Brackets for line drums.
 9. Tunnel yoke.
 10. Elevating Wheel.
 11. Curve Pulley, Curve drum and Rubbing bar.
 12. Conical drum.
 13. Cone Line drum.
 14. C.I. Yokes.
 15. C.I. Grease box and block.
 16. Automatic switch gear.
 17. Hand Switch gear.
 18. Hand Pick-up.
 19. Photo bunched strand.
 20. Photo kinked rope.
 21. Diagram of rope.
 22. Strand alarm.
 23. Rope History.
 24. Rope Splice.
 25. Grip.
 26. Crown Pulley.
-

* The Power Houses were built and equipped and the tracks constructed by the Melbourne Tramways Trust and leased to the Melbourne Tramway and Omnibus Co. Ltd. who provided the carsheds, workshops and rolling stock.

<u>— Cable Lines —</u>	<u>Length</u> <u>of</u> <u>Track</u>	<u>Cost</u> <u>of</u> <u>Track</u>	<u>Cost per Mile</u> <u>of</u> <u>Track</u>	<u>Cost</u> <u>of</u> <u>Drainage</u>	<u>Cost per Mile</u> <u>of</u> <u>Drainage</u>	<u>Cost</u> <u>of</u> <u>Maintenance</u>
<u>Richmond Line</u>	<u>Miles</u>					
<u>King's St. to</u> <u>Engine House</u>	3.615	93107 3 7	25735 15 11	3650 16	1009 8 1	1197 8 5
<u>Hygey Victoria St. Lines</u>						
<u>Collins St.</u>	1.547	41194 4 3	26621 19 9	1466 10	945 5 1	349 17 9
<u>Brunswick St.</u>	2.148	53363 12 9	25076 3 8	1751 19 8	315 12 8	1557 8 2
<u>Simpson's Rd.</u> <u>Engine House</u>	2.073	57213 7 8	27549 6 4	5010 7 10	3568 10	1063 1 11
<u>Collinwood & Nicholson St. Line</u>						
<u>Bourke & Nicholson Street</u>	3.305	73238 16 5	22139 18 2	4139 6 5	1251 6 1	91 - 1
<u>Smith's St. to</u> <u>Engine House</u>	2.250	53432 19 9	23747 10 11	1199 7 1	533 - 10	1580 - 2
<u>Brunswick Line</u>						
<u>Sydney Rd. to</u> <u>Engine House</u>	4.416	96906 4 7	21944 6 11	8790 4 9	1990 10 11	2195 13 3
<u>Carlton Line</u>						
<u>London & Johnston St.</u> <u>Engine House</u>	3.005	68548 5 2	22811 8 -	10446 8 8	3476 7 -	2578 8 10
<u>North Carlton Line</u>						
<u>Rathbone St.</u> <u>Engine House</u>	1.239	22936 5 1	18511 18 2	3748 17 2	3025 14 3	960 19 8
<u>North & West Melbourne Lines</u>						
<u>North Melbourne</u>	2.092	44158 15 10	21108 8 2	1649 6 9	788 8 1	481 10 3
<u>West</u> <u>Engine House</u>	1.610	31035 14 6	19275 12 2	2484 17 4	1729 14 7	142 17 3
<u>S. Hilda Lines</u>						
<u>No. 1 Section</u>	2.666	50212 5 3	18834 6 1	666 5 1	249 18 2	288 9 8
<u>No. 2</u> <u>Engine House</u>	2.350	61240 15 6	26059 17 2	777 16 10	330 17 11	133 12 5
<u>South Yarra Lines</u>						
<u>Prakran</u>	3.592	70469 - 6	19618 6 7	2835 17 9	789 10 -	858 1 9
<u>Toorak</u> <u>Engine House</u>	1.360	28914 10 7	21260 13 8	643 4 6	472 19 2	195 15 9
<u>Port Melbourne Lines</u>						
<u>Port Melbourne</u>	2.554	63050 1 1	24691 6 3	6278 12 2	2458 6 10	356 1 9
<u>South Melbourne</u> <u>Engine House</u>	1.864	37157 9 5	19934 5 4	2443 7 6	1310 16 5	752 12 9
<u>S. Hilda Esplanade Line</u>						
<u>Hygey Wellington St.</u> <u>Engine House</u>	1.974	48574 11 3	24607 3 5	888 16 10	450 4 11	1254 15 3
<u>Total Cable Lines</u>	48.663	995251 1 2	22793 15 6	62181 10 4	1424 2 6	16642 9 -
<u>— Horse Lines —</u>						
<u>Heron Lane Line</u>	1.666	10271 13 8	6163 9 6	263 10 -	158 3 3	280 6 4
<u>Hawthorn Horse Line</u>	2.127	16159 13 10	6657 2 5	80 19 3	28 13 3	415 2 5
<u>Total Horse Lines</u>	3.793	24431 7 6	6441 3 6	324 9 3	85 10 10	695 8 9
<u>Bridges</u>						
<u>Victoria St. Bridge</u>		6996 4 5		15 5 -		
<u>Hawthorn Bridge</u>		9972 12 9		2 13 -		
<u>Total</u>						

Station	Cost per mile of Belt & Pulleys		Cost of Engine House		Cost per mile of Engine House Building		Cost of Engine House Machinery		Cost of Engine House Machinery		Cost of Engineering		Cost of Engineering	
	of Belt	of Pulleys	of Engine House	of Engine House Building	of Engine House Building	of Engine House Machinery	of Engine House Machinery	of Engine House Machinery	of Engine House Machinery	of Engineering	of Engineering	of Engineering	of Engineering	
8 5	331 4 8	1004 13 10	277 15 5	7893 11 4	2183 11 2	15033 16 7	4158 16 8	2172 - -	501 - -	800 14 7	138 11 10	1		
7 9	226 4 9	30 10 -	19 14 3					962 - -		621 17 -		4		
2	789 - 3	121 15 8	522 4 11					1284 - -		597 15 3		5		
11	572 16 7	1154 - 3	556 13 4					1476 - -		712 - 3		6		
				17706 13 2	3069 17 1	27260 - 11	4720 15	977 14 10		169 10 2		4		
1	27 4 2	82 11 5	263 15 6					1410 - -		516 18 7		8		
2	135 11 1	1168 4 9	492 11 -					1270 - -		564 9		5		
				14855 11 9	3217 12 7	30563 19 8		1058 - -		190 7 1		4		
3	497 4 1	2805 3 10	454 1 5					2398 - -		523 - 6		11		
				15244 11 11	3452 2 6	19741 18 11	4470 11 -	762 - -		172 11 1		3		
10	957 14 8	2901 9 -						18 56 - -		617 12 9		8		
				12791 4 5	4256 12 11	17254 15 2	5831 17 4	662 - -		220 6 -		30		
8	775 12 4	1630 7 5	1315 17 6					640 - -		516 10 10		2		
				6857 - 9	5534 6 7	9159 10 10	7392 13 10	351 - -		283 5 10		1		
3	230 3 4	1498 - -	716 1 3					1046 - -		370 - -		4		
14 3	88 14 8	1219 4 4	757 5 6					771 - -		478 17 8		30		
				15014 16 6	4054 17 4	20030 12 2	5410 15 1	765 - -		206 12 11		3		
8	768 4 3	2585 12 5	969 17 -					1172 - -		439 12 2		50		
5	57 14 3	1388 16 2	590 19 9					1877 - -		585 19 1		60		
				15077 14 2	3005 16 5	20573 18 9	4101 13 3	778 - -		155 2 1		30		
9	238 17 9	1901 13 7	529 8 5					1664 - -		462 5 -		70		
8	143 17 -	474 18 -	369 3 10					660 - -		485 5 11		30		
				18785 5 1	3833 17 1	25538 18 2	5761 6 7	973 - -		136 9 9		4		
1 9	181 11 16	1639 10 2	602 - 4					1523 - -		604 3 -		70		
9	149 1 7	802 12 4						915 - -		470 17 8		40		
				18020 7 -	4078 17 -	20937 4 8	4739 1 5	852 - -		192 17 -		30		
3	635 18 2	1518 3 6	774 3 -					1143 - -		579 - 6		50		
				4392 7 6	3744 14 5	10889 4 9	5870 6 8	400 - -		202 12 8		11		
-	381 5 10	2556 14 7	585 8 2					152867		780 1 3		150		
				8 7	358 1 6	21727 7	4976 3 2	82138 14 10		780 1 3		150		
4	165 5 2	3 - -	1 16 -					209 - -		143 9 2		11		
5	195 3 4	261 14 9	123 - 10					331 - -		155 12 5		10		
4 9	183 6 11	264 14 9	69 16 -					570 - -		150 5 6		26		
								153 - -				7		
		169 5						221 - -				10		
7 9		2594 14 4						217270 - 4 7		330 8 7 14 10		150		

Acres		Total Cost		Total Acres		Cost of Land for		Cost of		Total Cost		Total Cost for					
of	of	of	of	of	of	of	of	of	of	of	of	of	of				
Improvements	Construction	Improvements	Construction	Land for	Land for	Land for	Land for	Administration	Administration	System	System	System	System				
				Engineering	Engineering	Engineering	Engineering	Legal & Office	Legal & Office								
								Expenses	Expenses								
820	167	101132	1 10	27975	13 8			3009	-	854	9 11	104221	1 10	28830	3 7		
8	11 10	23328	7 11	6250	17 8	4008	5 5	1108	5 9	853	-	28274	13 4	4821	9 8		
1	17 -	43993	15	28038	-			1344	-	868	15 7	45337	15 -	29306	16 6		
7	15 3	59608	16 3	27450	16 10			1821	-	887	15 4	61429	16 3	28598	12 2		
2	- 3	68925	14 8	33249	6 9			2105	-	1015	8 9	71030	17 8	34264	15 6		
3	9 10 2	45944	15 11	7965	8 11	9409	2 5	1631	5 2	293	3 6	57044	16 4	9889	17 1		
516	18 7	80050	14 4	24199	2 6			2445	-	739	2 4	82095	14 4	2438	4 10		
4	9	58890	11 9	26173	11 10			1799	-	799	11 1	60689	11 9	26973	2 11		
9	7 1	49505	11 5	8907	1 8	13548	5 -	2437	12 3	340	10 6	64979	16 5	11091	4 3		
3	- 6	112295	6 5	25429	3 10			3430	-	776	14 5	115725	6 5	26205	18 3		
2	2 11 1	35748	10 10	8095	4 7	2536	16 4	574	9 3	263	12 4	39454	7 2	8934	8 2		
1	12 9	86630	6 4	28828	14 5			2646	-	880	10 8	89276	6 4	29709	5 1		
2	0 6 -	30977	19 7	10308	16 3	6268	19 11	2080	3 9	378	14 -	38384	19 6	12773	10 -		
4	10 10	29916	9 4	24145	13 1			914	-	757	13 10	30830	9 4	24883	6 11		
2	3 5 10	16367	11 7	13210	6 3	2542	3 9	2037	16 1	466	10 2	19487	15 4	15728	12 6		
2	3 - -	48833	12 10	23343	- 10			1492	-	713	3 10	57325	12 10	24056	4 8		
4	8 17 8	38951	13 5	22330	4 7			1098	-	681	19 9	37049	13 5	23012	4 4		
6	12 11	35810	8 8	9673	5 4	16578	13 6	4462	1 11	431	13 2	53927	2 2	14567	- 5		
5	9 12 2	54924	12 5	20601	17 8			1678	-	629	9 2	56602	12 5	21231	5 10		
5	19 1	64919	18 11	27625	10 2			1998	-	843	16 7	66902	18 11	28469	6 9		
1	5 2 1	36429	12 11	7262	13 9	2363	9 7	471	3 9	236	4 10	39978	2 6	7970	2 4		
1	3 5 -	77728	13 7	21639	7 8			2374	-	660	15 3	80102	13 7	22300	6 -		
4	5 5 11	30888	5 4	22711	19 7			943	-	693	7 7	31831	5 10	23405	7 2		
1	6 9 9	46517	3 3	9191	13 5	3378	- 7	682	3 1	1442	18 -	50135	2 7	10175	10 2		
6	0 4 3 -	72856	9 2	28526	8 3			8225	-	871	3 8	75881	9 2	29397	11 11		
-	5 14 8	52764	6 2	22942	4 6			1386	-	700	12 10	44070	6 2	23642	7 4		
1	5 17 -	39809	11 8	9010	15 5	13171	- 6	2981	4 4	360	4 7	54598	12 4	12338	4 4		
1	7 - 6	53389	5 10	27046	5 -			1631	-	820	4 9	53720	5 10	27872	9 10		
2	2 12 8	18681	12 3	9463	16 9	2926	9 2	1482	10	660	-	22268	1 5	11250	13 8		
7	0 1 3	1501921	19 1	34398	- 11	76671	6 2	1955	19 7	48217	18 9	1104	6 5	1626811	4	37258	6 11
3	9 2	11057	10 -	6637	3 1			338	-	202	17 7	11395	10	6840	- 5		
-	5 12 5	15228	10 3	7159	12 3			465	-	218	12 5	15693	10 3	7378	4 8		
1	2 5 6	26286	- 3	6930	2 9			803	-	211	14 2	27089	- 3	7141	14 11		
		7164	9 8					219	-			7383	9 8				
		10365	10 9					317	-			10682	10 9				
3	- -	1545	19 9			76671	6 2	49556	18 9			167166	4 8				

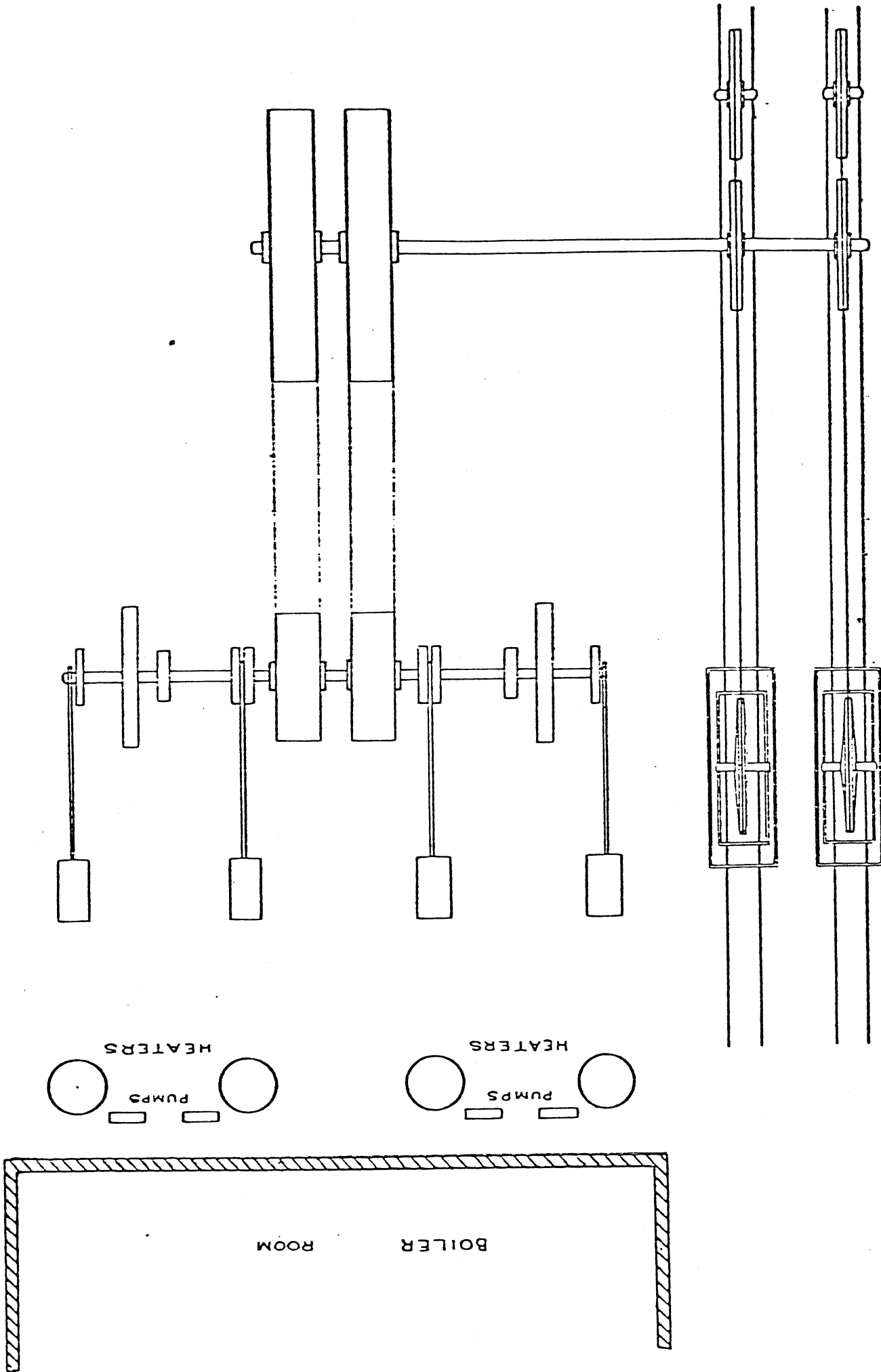

TYPICAL POWER HOUSE LAYOUT

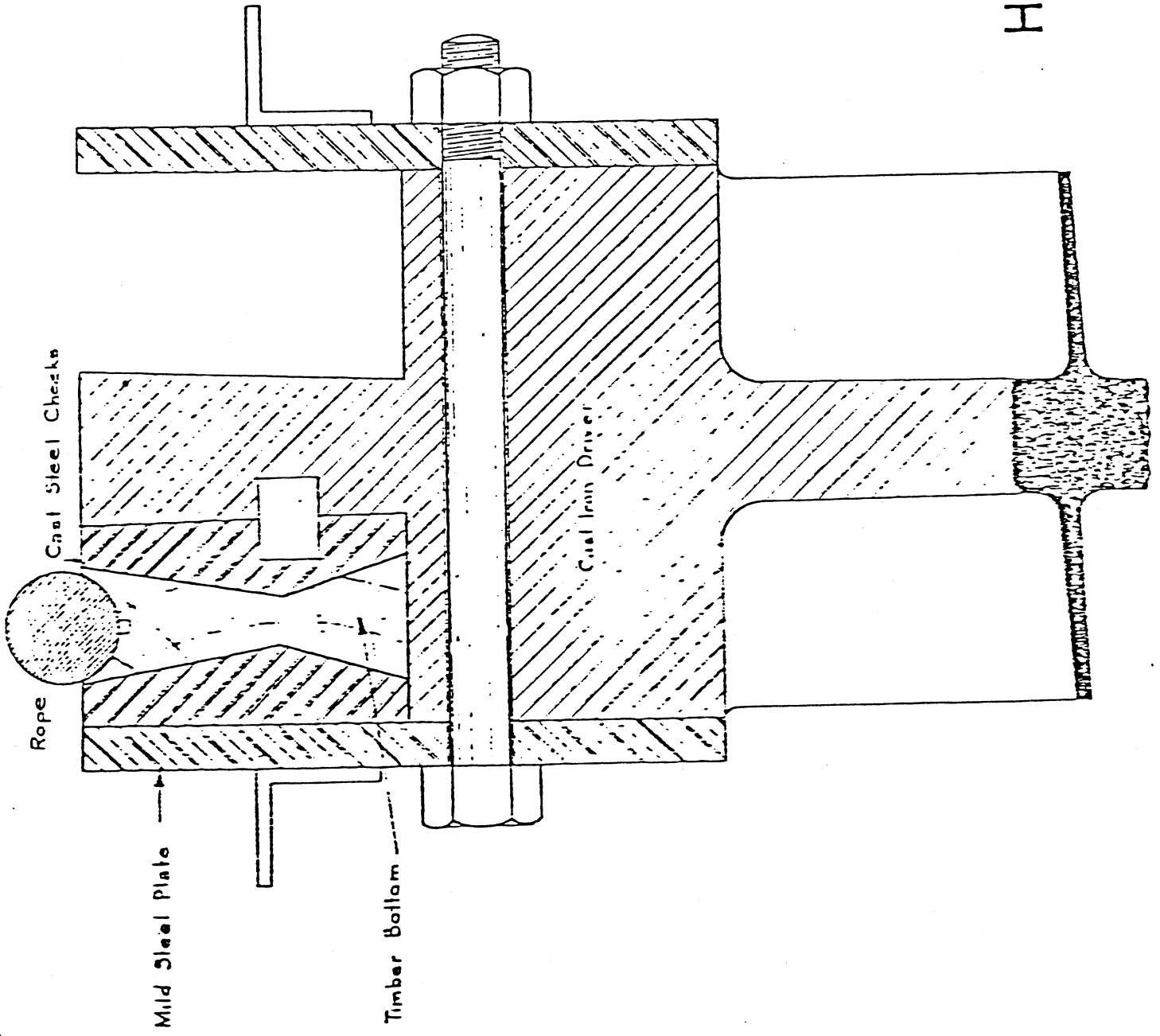

HEAD OF CABLE DRIVER

SECTION

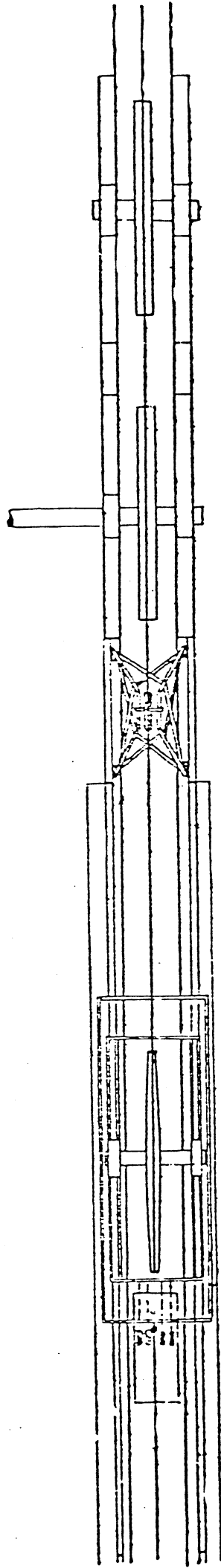
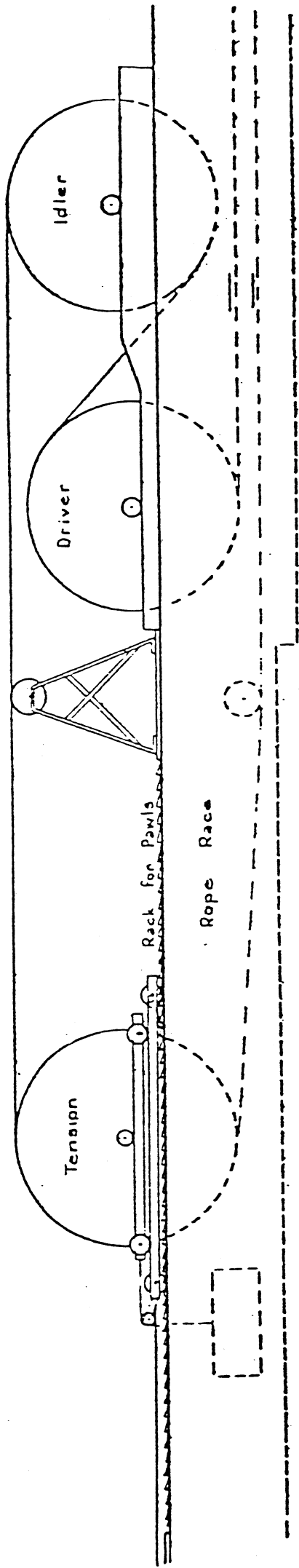

ROPE DRIVE

FUEL TEST - REPLAINADE POWER HOUSE, ILL., 1918

Coils from One Company (Moisture) Rollers 2 & 3 multistubular (made in Helbourne) Marine Type Fox's Corrugated furnaces.
 ex South Illinois Works (adjusted to) Air admitted under firebars from bell by pipe led through combustion chamber.
 used on received (8) In arches in combustion chamber. Narrow fly-burn spaced 1/40" apart.
 rhovelled coils (standard) Steam jet under firebars and also in overhead flues used intermittently.
 i.e. not sorted. Grate area 24 sq. ft. - 48 sq. ft. for 2 boilers.
 Heating surface 750 sq. ft. each boiler x 2 = 1500 sq. ft.

1 week test

COKE RECEIVED 1918	FUEL USED PER DAY 24 hrs.		ASH FROM DAYS FUEL	ASH %	No. Traffic hours during test	Fuel used in Traffic hours	Comb. used in Traffic hours	Water used in Traffic hours	Water evaporated (f & a 212) Per lb. Fuel Combustible	Fuel per hour per sq. ft. Grate Area	Lbs water fed a hr per sq ft Heat Surface	Moisture in Coke Deducted from fuel for C. moisture used standard	Fire cleared Traffic hours	Fuel used in actual moisture i.e. if no moisture deductions
	T. C.	Q. LBS.												
Thurs. May 9	5	15 0 15	15 0 15	13.1	18	11596	10071	74592	6.8 X	13.4	2.92	16.5	6	6 5 3 4
Fri. " 10	4	17 1 1	12 2 14	13.1	18	9635	8371	72576	7.99	11.1	2.85	17.8	4	5 7 3 6
Sat. " 11	5	6 1 10	12 2 20	12.0	18	10691	9413	76608	7.6	12.4	3.0	15.5	4	5 14 3 23
Sun. " 12	3	3 3 24	7 3 13	12.3	9	5172	4535	44664	8.59	12.0	3.3	19.1	2	3 11 3 22
Mon. " 13	4	19 2 5	11 1 3	11.3	18	9682	8576	77230	8.48	11.2	3.0	15.2	4	5 6 1 6
Tues. " 14	4	18 3 20	10 2 10	10.7	18	9764	8719	76608	8.3	11.3	3.0	14.7	4	5 6 0 3
Wed. " 15	4	16 1 8	12 1 2	12.7	18	9755	8513	73218	7.97	11.3	2.88	15.3	4	5 3 3 17
TOTALS	33.17	1. 27	82. 2. 12	-----	117	66298	58198	492876	-----	-----	-----	-----	28	36 16 3 4
AVG. 7 days	4. 16.	3. 13	11. 3. 6	12.2	-----	-----	-----	-----	7.96	11.8	2.99	16.3	---	5 5 1 1

Digrams taken Tuesday, 14th, see Sheet No. 1. Calorific value of fuel see Dun & Sons report attached.

NOTE - Fuel shown as used is adjusted to 8% Moisture (as paid for) 2-19-1-5 fuel deducted from amount actually used.

X Bed Fuel on Thursday 9th May.

MELBOURNE AND METROPOLITAN TRAMWAYS BOARD

Boilers at work Nos 2 & 3 multitubular made in Melbourne. Fuel test for week - see other sheet. WEATHER: Rainfall nil, max shade temp. 69.1° 24 hours. 30.9° min

Hour	H.P.	TRAM OUT	H.P. PER TRAM
6:00	112	1	112
6:30	132	2	66
7:00	123	2	61.5
7:30	123	64	18.9
8:00	140	7	20.0
8:30	200	10	20.0
9:00	140	12	11.7
9:30	176	13	13.5
10:00	154	11	14.0
10:30	148	11	13.4
11:00	161	11	14.6
11:30	154	11	14.0
12:00	136	11	12.3
12:30	160	11	14.5
1:00	200	12	16.6
1:30	176	13	13.5
2:00	165	13	12.7
2:30	216	14	15.4
3:00	164	13	12.6
P.M.	3980	1047	16.1
TOTAL	152	15	10.1
4:00	144	14	10.3
4:30	176	14	12.6
5:00	196	15	13.1
5:30	200	17	11.8
6:00	180	15	12.0
6:30	184	13	12.6
7:00	144	10	14.4
7:30	164	12	13.7
8:00	160	11	14.5
8:30	156	11	14.2
9:00	142	11	12.9
9:30	152	11	13.8
10:00	157	11	14.2
10:30	157	11	14.2
11:00	160	11	14.5
11:30	220	6	36.6
12:00	136	7	68.0
TOTAL	2960	210	14.1

Totals 5940 3947 15.1
 27 cards 161 10.7 15.1

15.1 HP per Tram

Engine runs 72 per minute. 480' piston speed per minute
 Boiler pressure 100 lbs at 11 a.m., 100 lbs at noon 82 at 1.30 p.m., 100 at 2 p.m.
 80 lbs at midnight. Scale 1/40.

ADP SPEC 12.17 m.p.h. on gear save for the day.

ft. lbs ft	T	C	0	lbs
Winder 21291	A	24	22	16-0-26
THAN MILLS	Trips x Miles round trip 4,032 miles			
Explanade	340.5 x 2,806 = 955.44) 1 dummy, 1 car			
Winder	137 x 3,792 = 512.5) - 1 tram.			
Dummy & Car (empty)	5-3-0-0 = 5.15 tons x 1474.9 tram miles			
	= 7596 ton.miles empty cars hauled 1 mile.			

EXTRA CARDS

HP	HP	Ropes & Machinery only
5.10 pm	180	228
5.20 pm	188	148
5.40 pm	164	100
		Average
		112
		108
		106
		109 h.m.a

Revs 72 boiler pressure 100 lbs. Revs 72 boiler pressure 80 lbs

Diagrams taken by W.A. Pollock, K.L. Mackenzie relayed for meals.

FUEL	T	C	Q	lbs
Used in 18 Traffic hours	417	0	120	3 20/- 1 4 7 2
" " night watch	111	21	0	9 764
" " 24 hours	418	21	0	1316
ASH 24 hours C-10-2-10	1186	10	10.7	1000
Fires cleaned 4 in Traffic hours				

EVAPORATION water and fuel weighed by special men
 9764 lbs coke used in 18 traffic hours = 342 lbs per hr.
 76608 lbs water (weighed at pumps) 18 traffic hours = 4256 " "
 61204 " water (f.a. 212° 1.06) 18 " = 4314 " "
 9764/76608 (7.88 lbs water evaporated per lb. of coke)

Temperature water at entrance to boiler 192°
 for equivalent evaporation f & A 212° x 1.06

8.3 lbs water evaporated f & A 212° per lb coke } Average moisture 14.7 = 8 allowed
 2.2 " " " " " " " " " " " " " " } = 6.7% deducted in weight of fuel.

WATER per hr per average H.P., 26.4 lbs 161/4256(26.4 lbs
 FUEL " " " " " " " " " " " " " " 161/542(3.36 "

Cost of fuel per ton mile hauled 0.80d = 24 hours
 Quantity fuel " " " " " " " " " " " " " " 0.709d = 18 hours
 Five temperatures by thermometer Boiler No. 2 328° F, No. 3 389° F = average 18 hours

Note as Gas Co. is paid for 8% moisture in coke above days moisture = 14.7% so 6.7% deducted.

Coke actually used	T	C	Q	Lb	Might Watch	Total					
deduct 6.7% excess	4	13	1	21	12	2	10	3	6	0	3
moisture	4	7	0	20	11	3	10	7	0	0	11

AS A CHECK

Trips	round	day run	HP
339	x 21	=	1111
137	x 30	=	965
		=	6.4
		=	4.25
		=	10.63 average tons out.

10.65/1161 (13.1 HP per ton)

MELBOURNE & METROPOLITAN TRAMWAYS BOARD

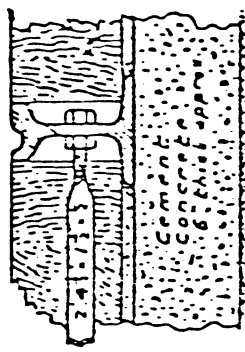
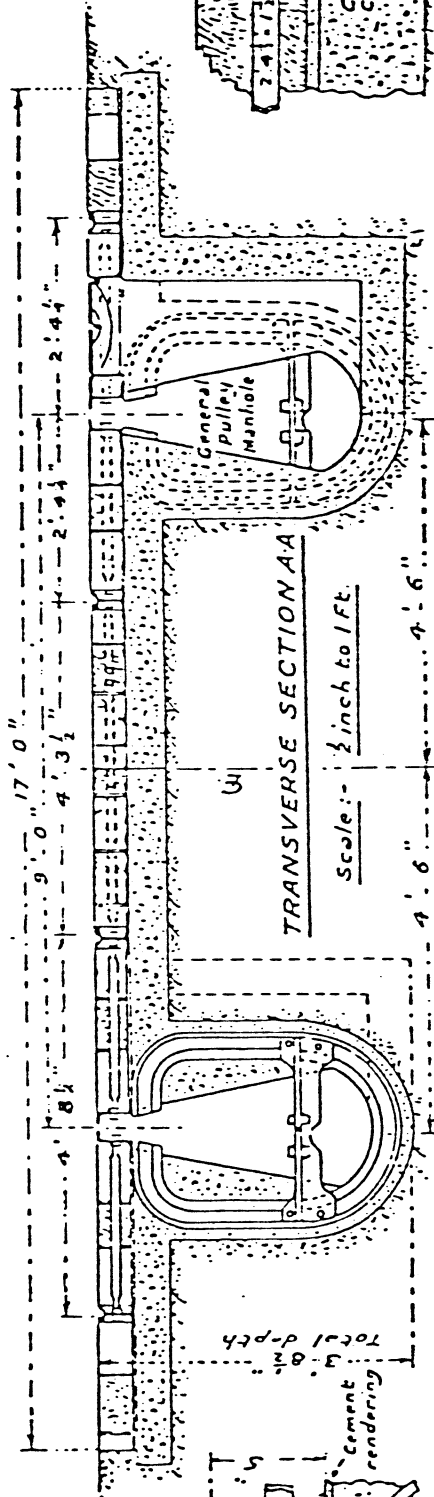

DETAIL AT YOKE. A.
Scale: 1/2 inch to 1 ft.

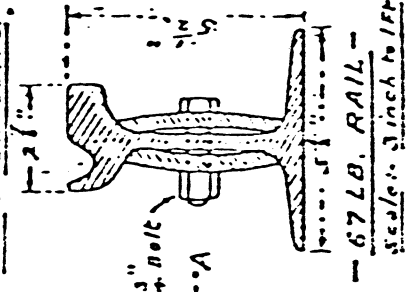
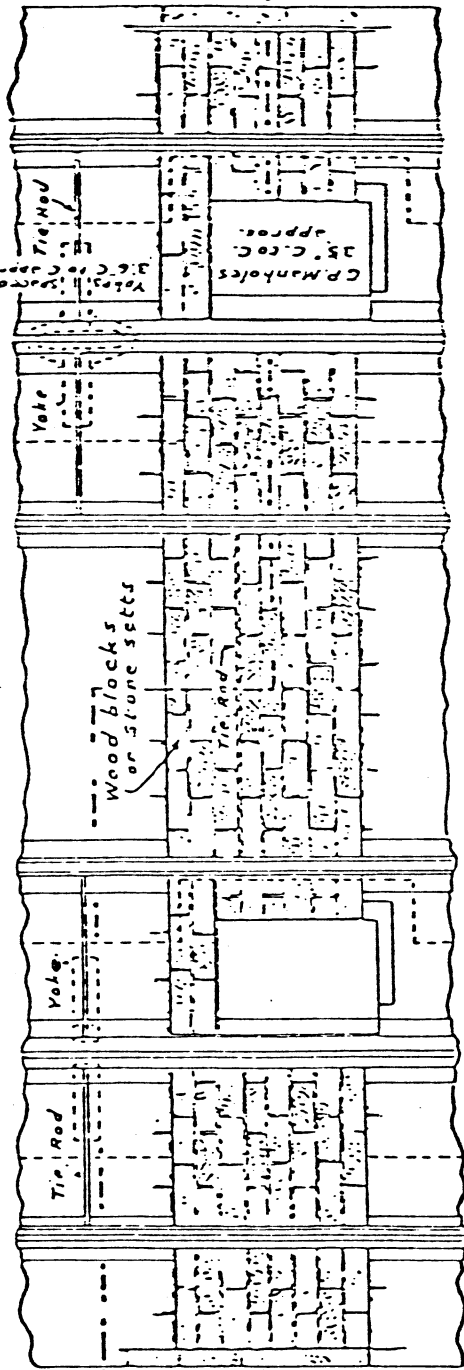
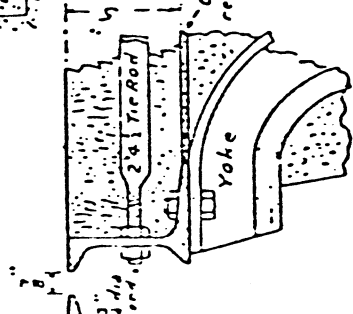

52 LB. SLOT BEAM
Scale: 3 inches to 1 ft.

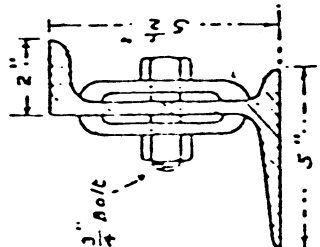

CABLE TRAMWAY, 67 LB. RAILS

MELBOURNE & METROPOLITAN TRAMWAYS BOARD	
<i>D.P. Griffiths</i> CHIEF ENGINEER	
DATE: 10/11/14	PROJECT: P.W.S.
BY: J.W. 11081	SCALE: 1/4" = 1'
CHECKED: 5.8.14	
SCALES AS SHOWN	DRAWING NUMBER P.2314.

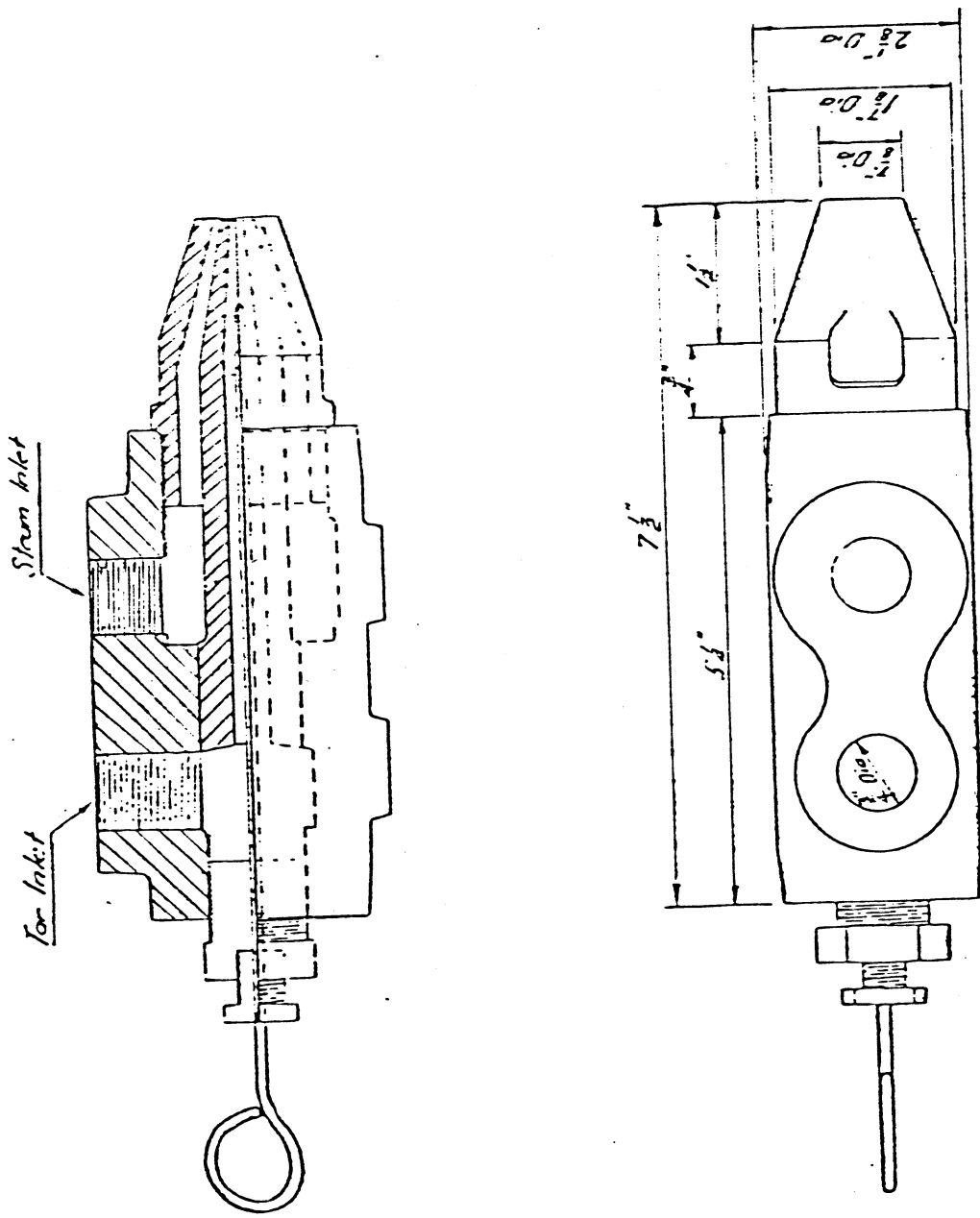

TAR-BURNER USED BY M.T.O. COY.
1893-1900

Sheet No. 5.4

A I PULLEY

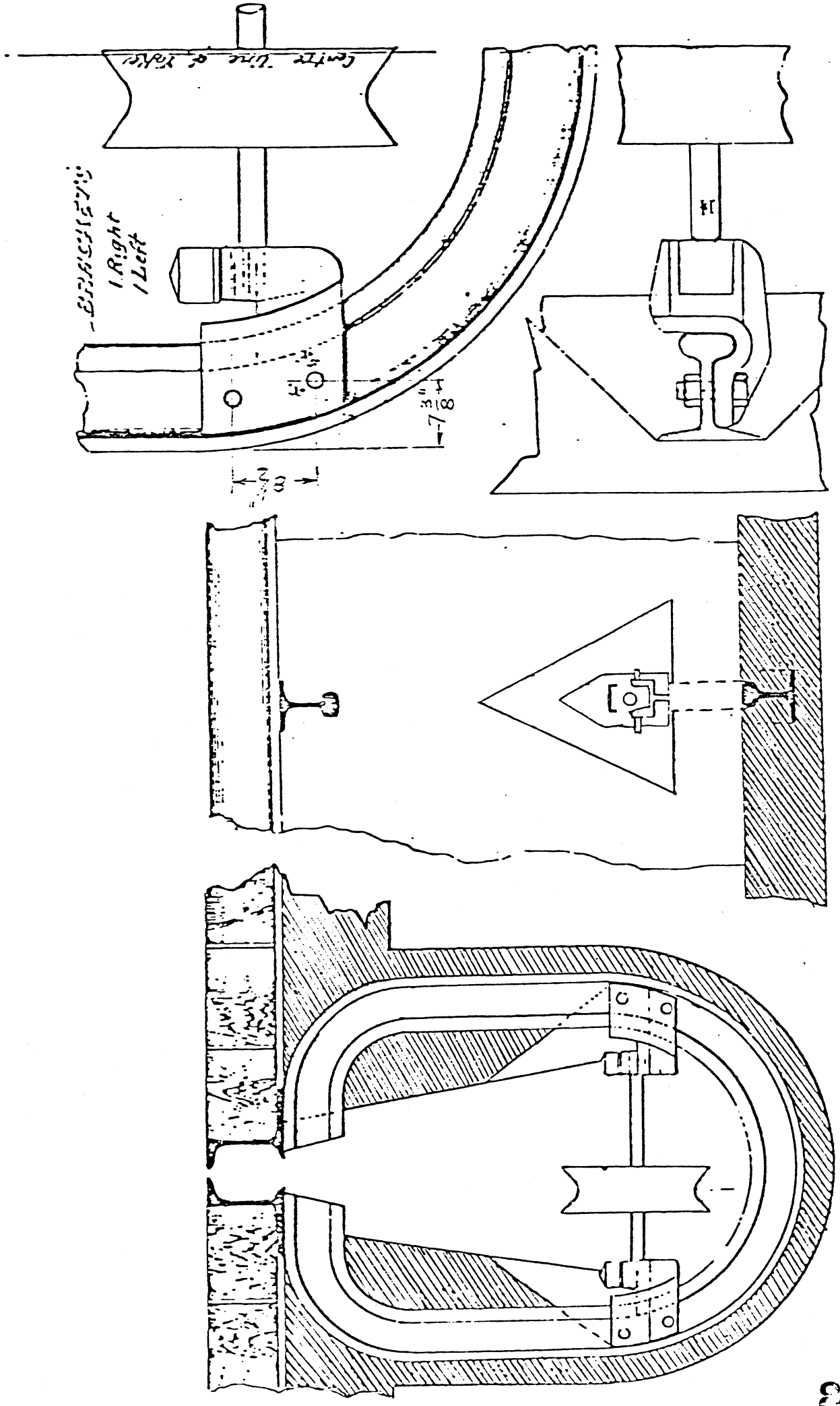

PLAN SHOWING YOKE

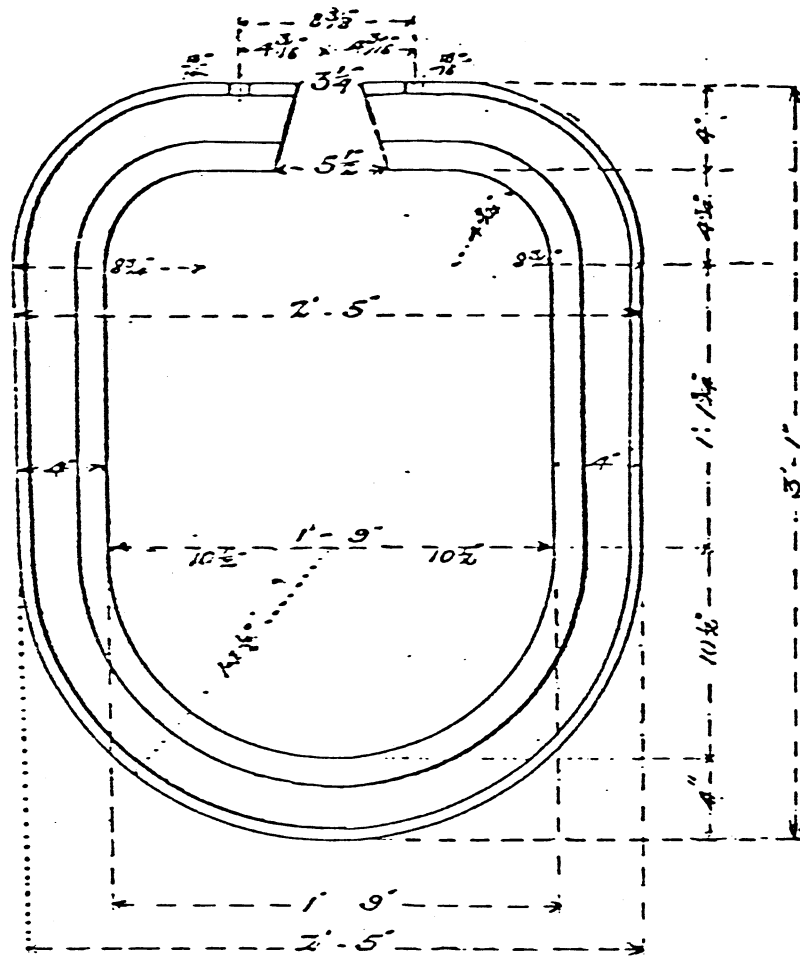

Section of 50lbs. Rail
 FULL SIZE
Boné to the form shown above

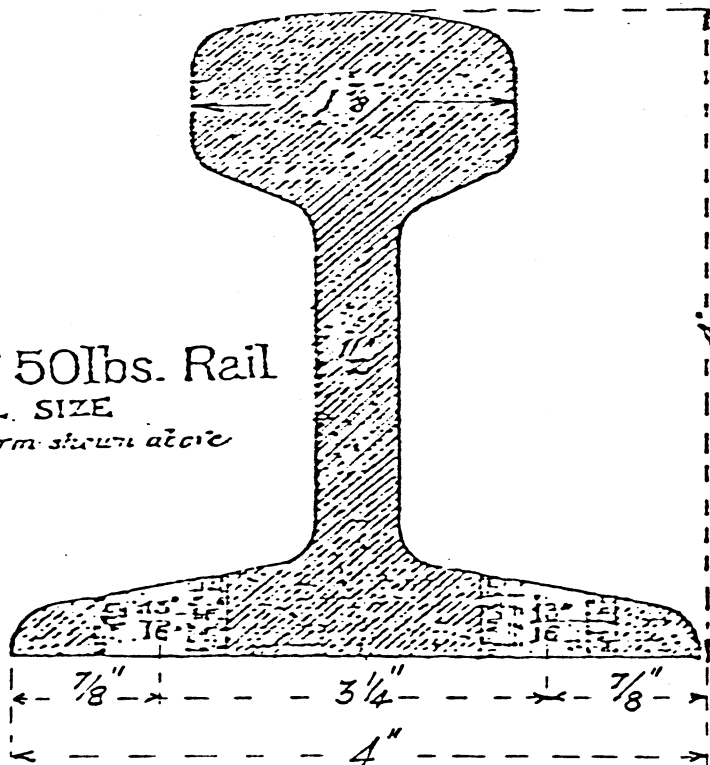

— P1744

ELEVATING PULLEY
WITH
SHIELD PLATE

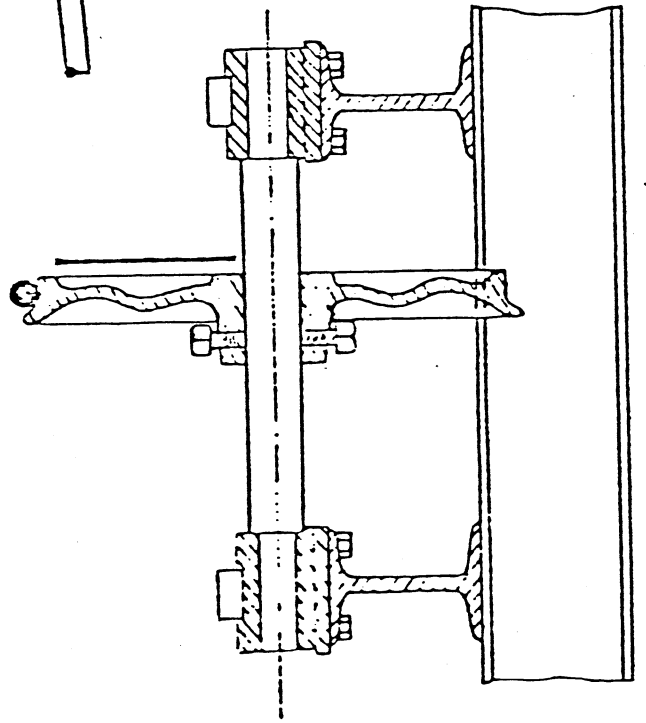
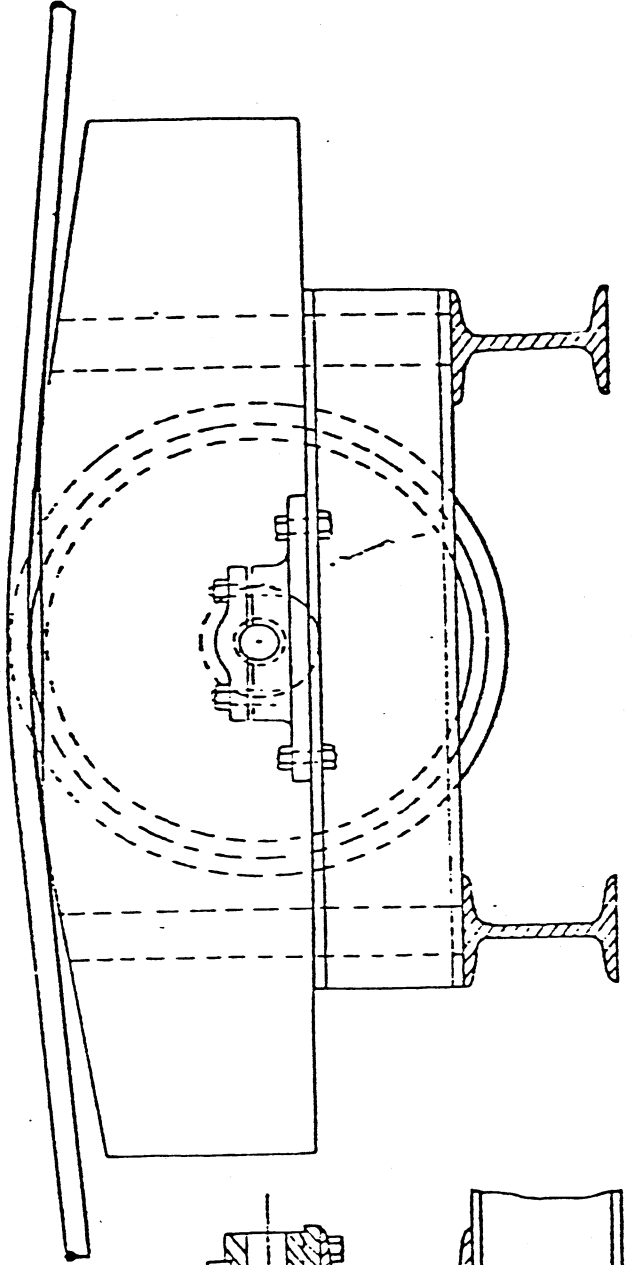
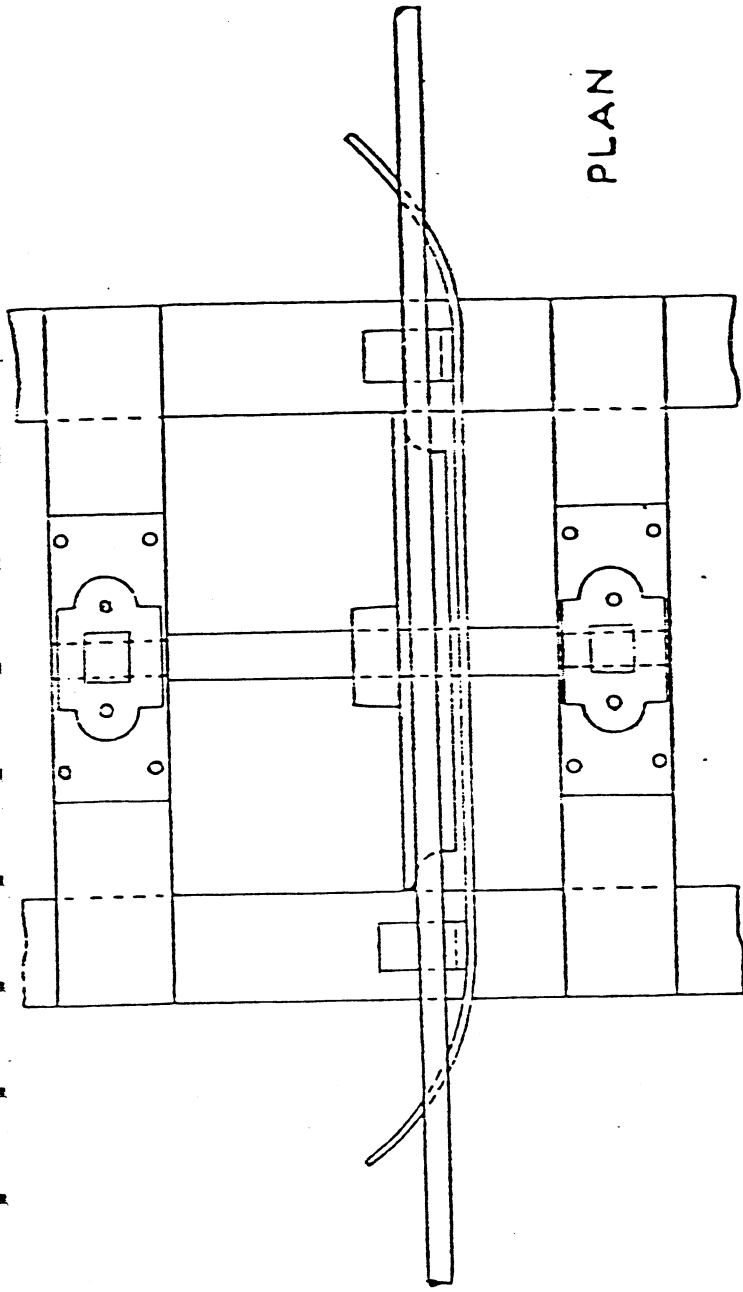

CURVE PULLEYS

CURVE PULLEY RIM
FULL A. SIZE

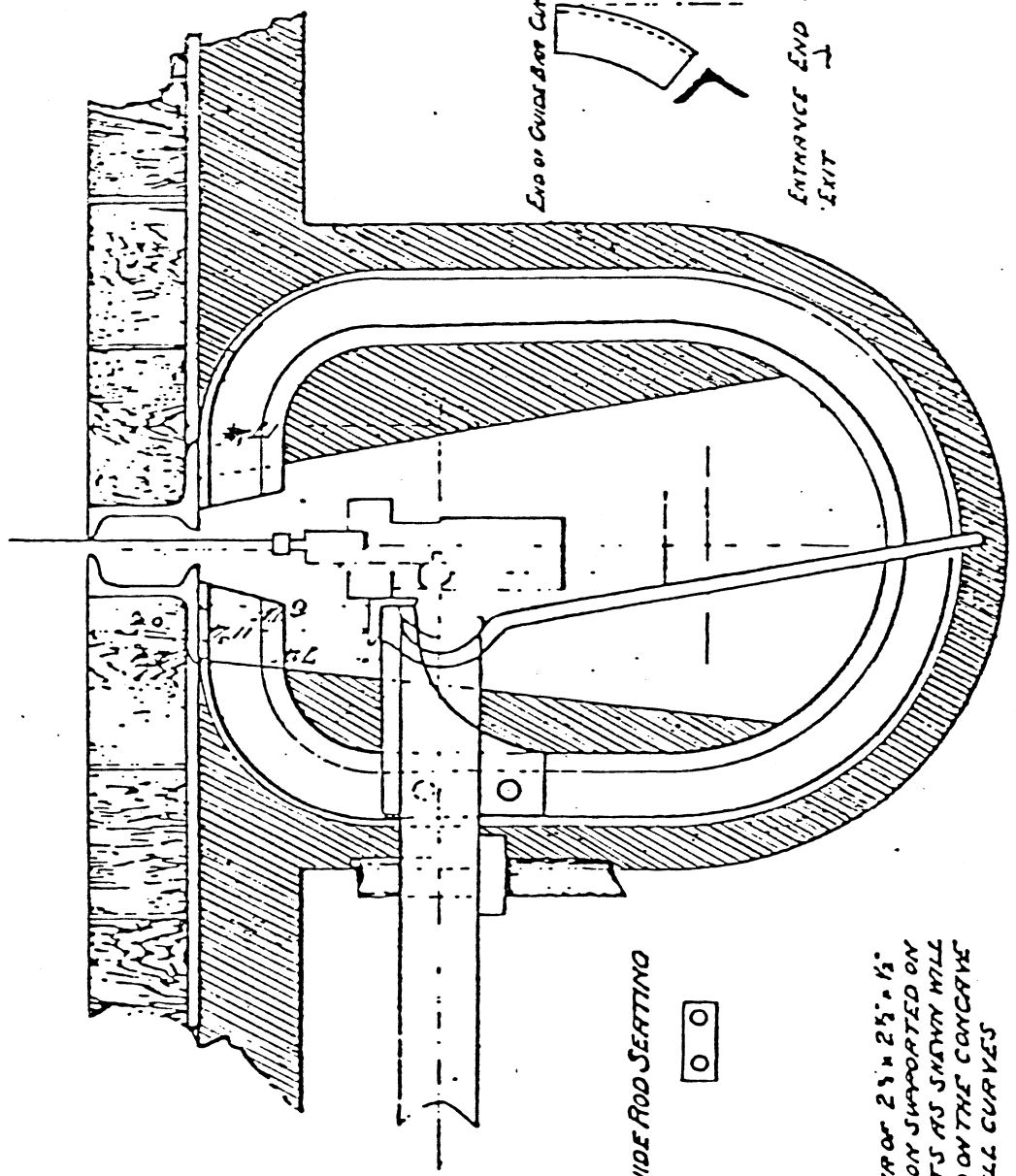
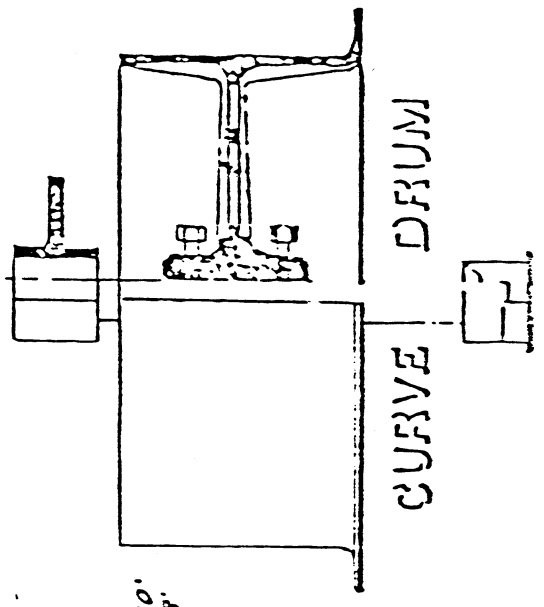
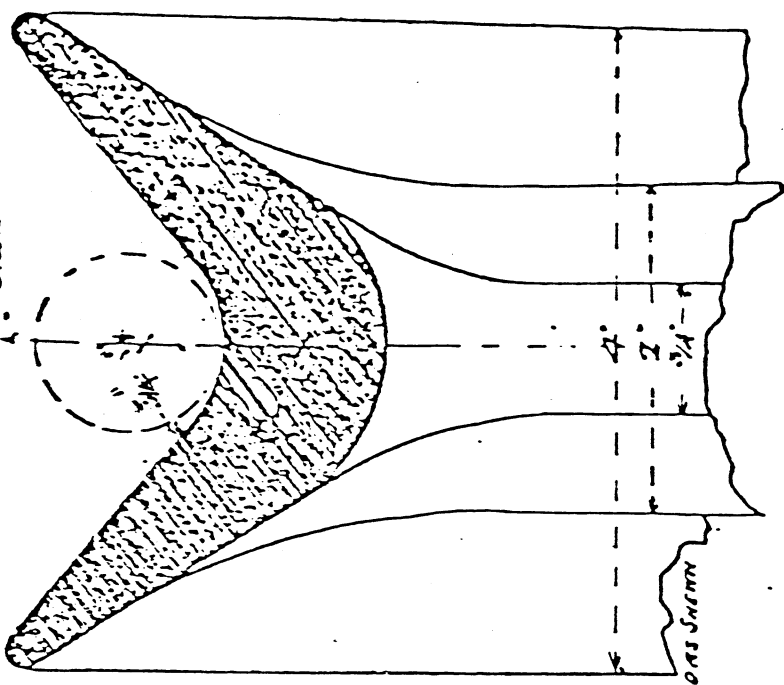

END OF GUIDE BAR CURVISORS SHOWN

ENTRANCE END 10'
EXIT 8'

GUIDE ROD SEATING

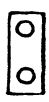

NOTE:
GUIDE BAR OF 2 1/2" x 2 1/2" x 1/2"
ANGLE IRON SUPPORTED ON
BRACKETS AS SHOWN WILL
B.E. FIXED ON THE CONCRETE
SIDE OF ALL CURVES

1 (ONE) GUIDE ROD TO
EACH CURVE PULLEY

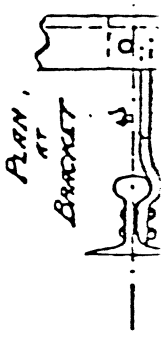

PLAN AT
BRACKET

SCALE, 1 1/2" = 1 FOOT

CURVE DRUMS

SCALE: 1/2" = 1 FOOT

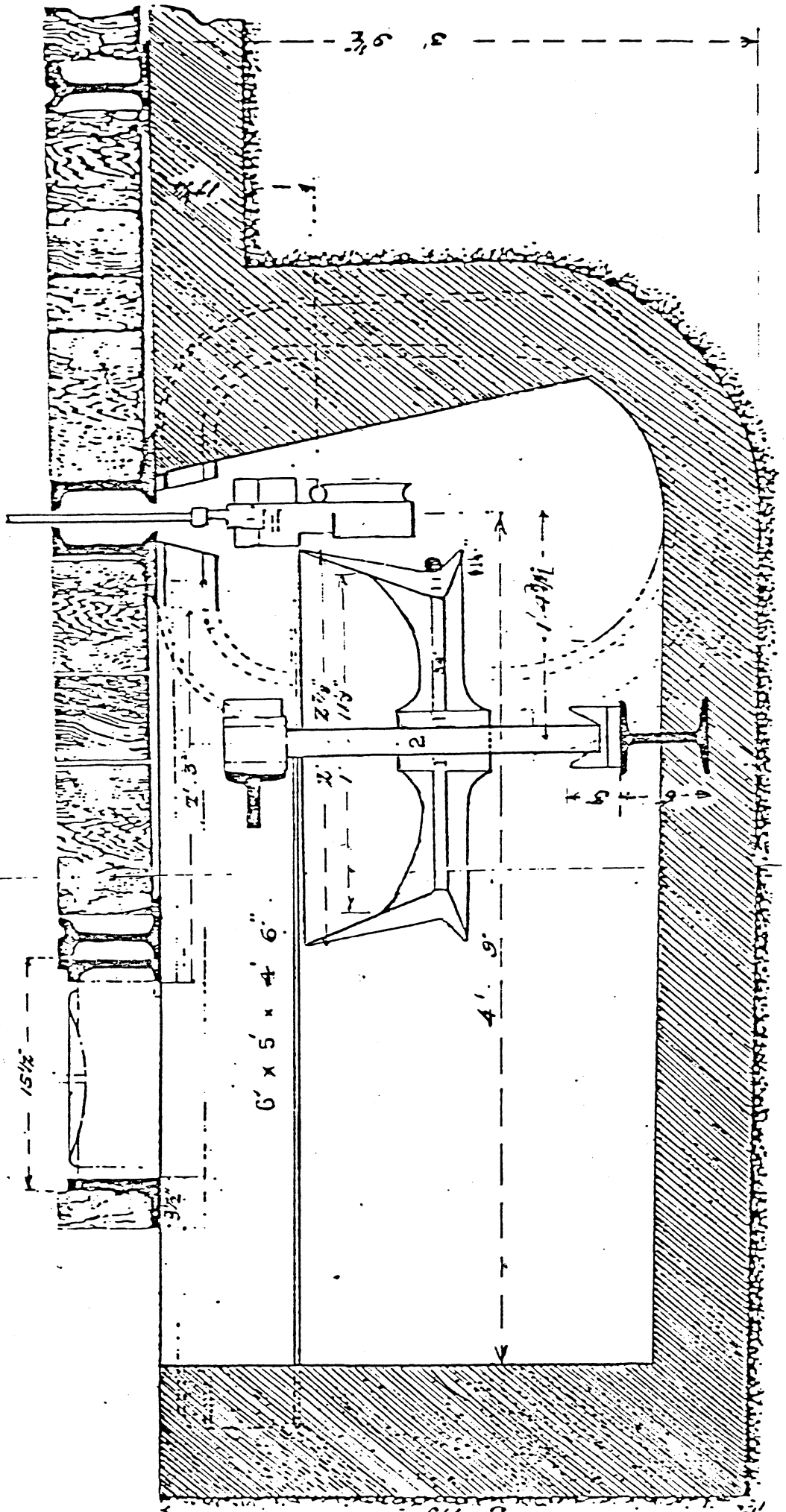

SCALE 1/4" = 1 FOOT

CABLE SEPARATING PULLEY

CROSS SECTION AND PLAN

OF

MAN HOLE

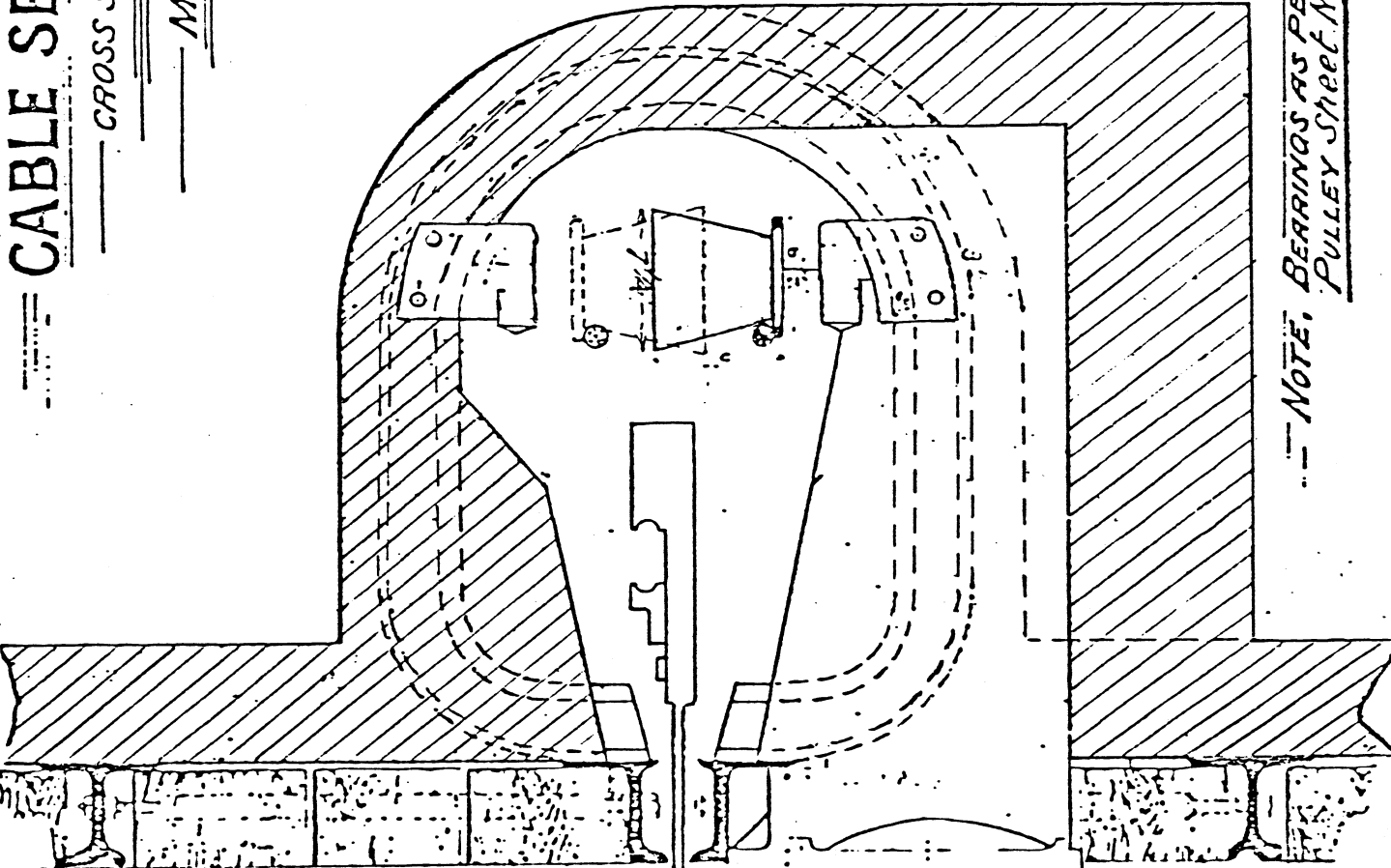

NOTE, BEARINGS AS PER A1 PULLEY SHEET No.

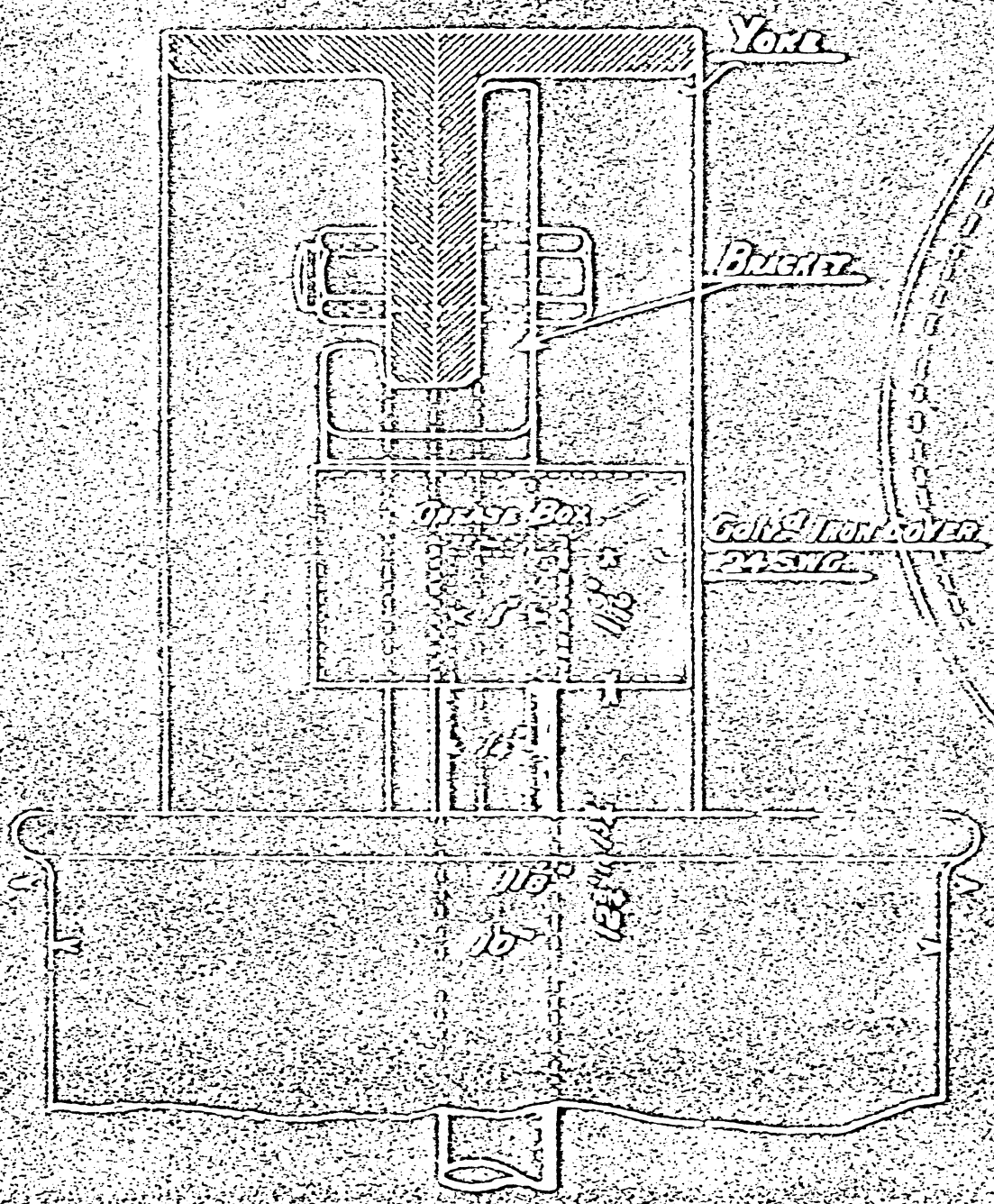

M. & M. I. B.

YOKE BRACKETS FOR DRUMS

B 13, 14 & 15.

See. W. & S. S.

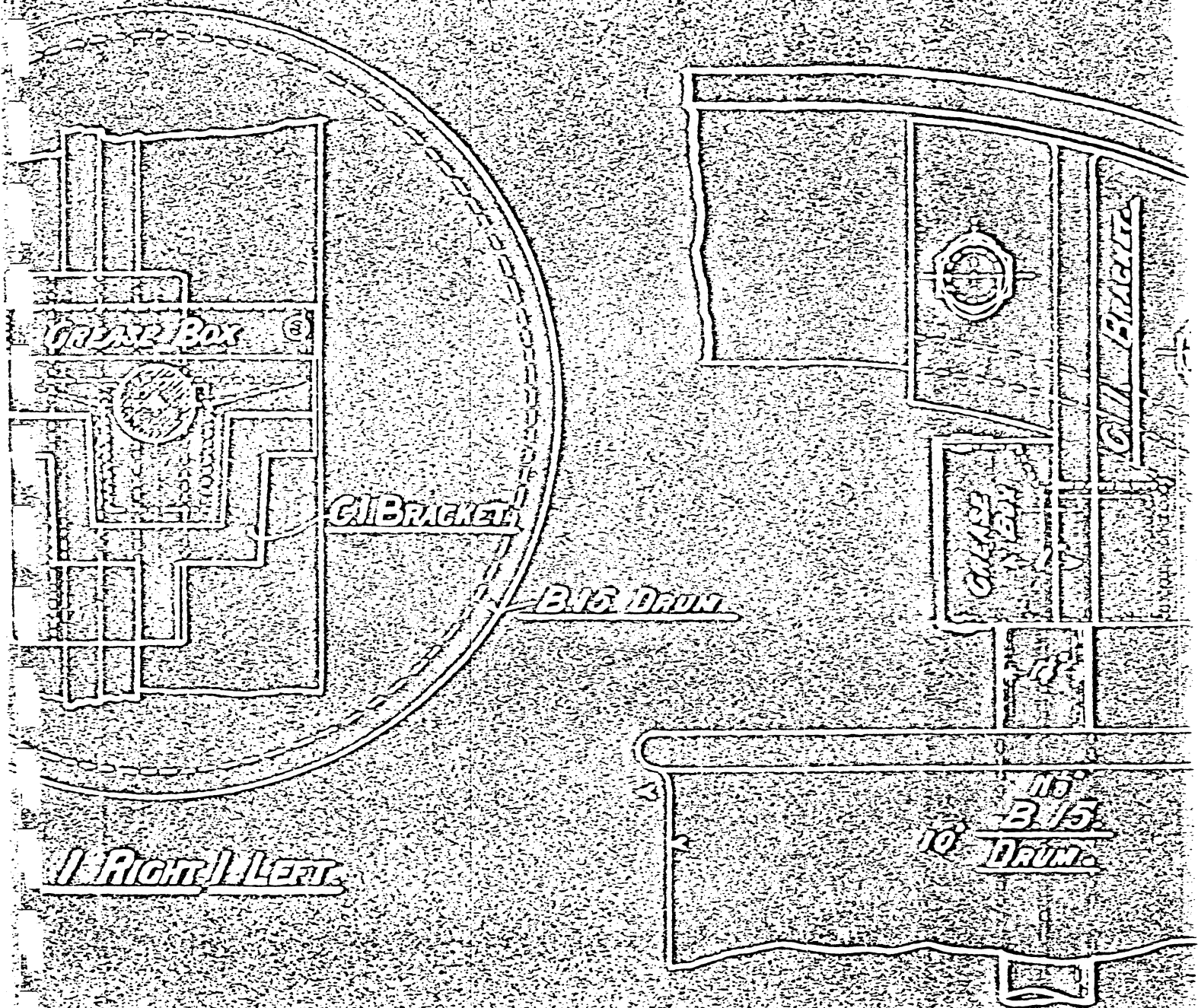

RIGHT / LEFT

INSIDE BEARING

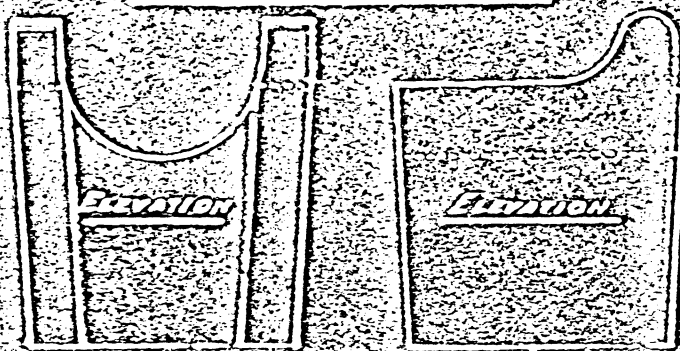

FULL SIZE

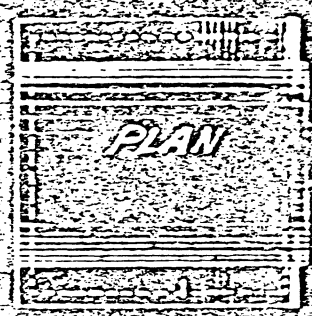
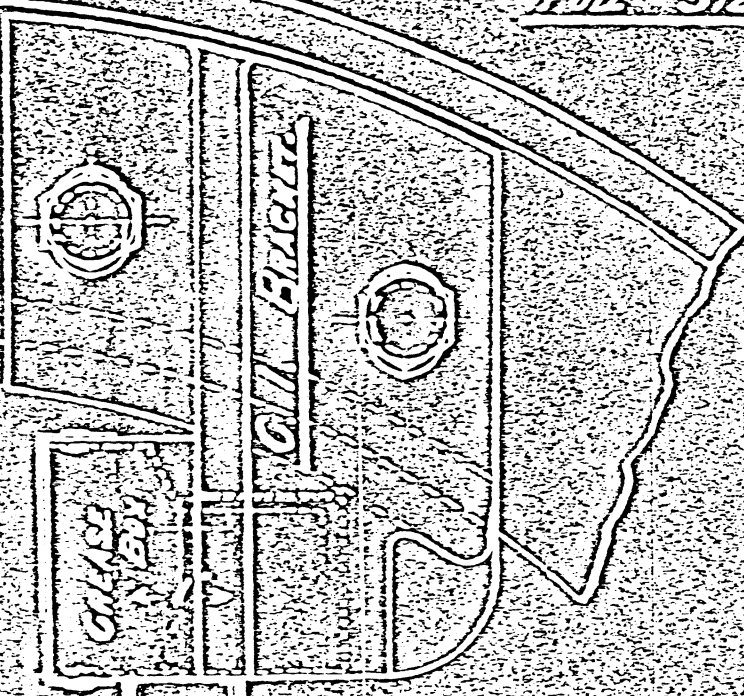

16"
B 15
10" DRUM

CONTRACT NO.

SHEET NO.

DRAWING NO. 895

15

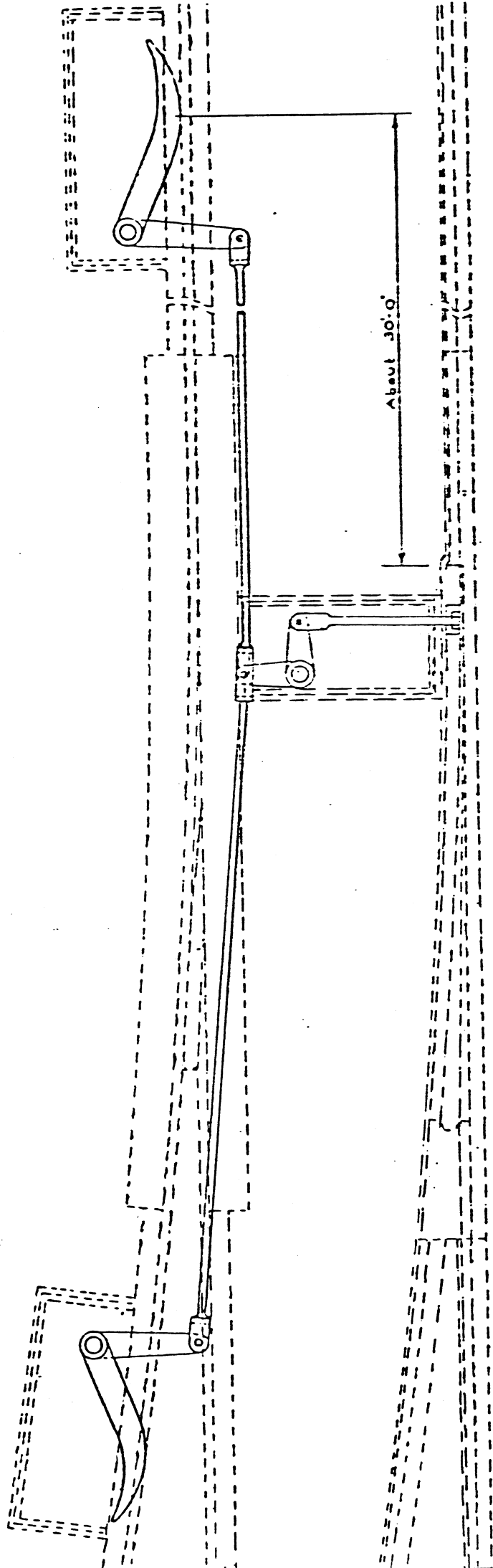

AUTOMATIC SWITCH GEAR

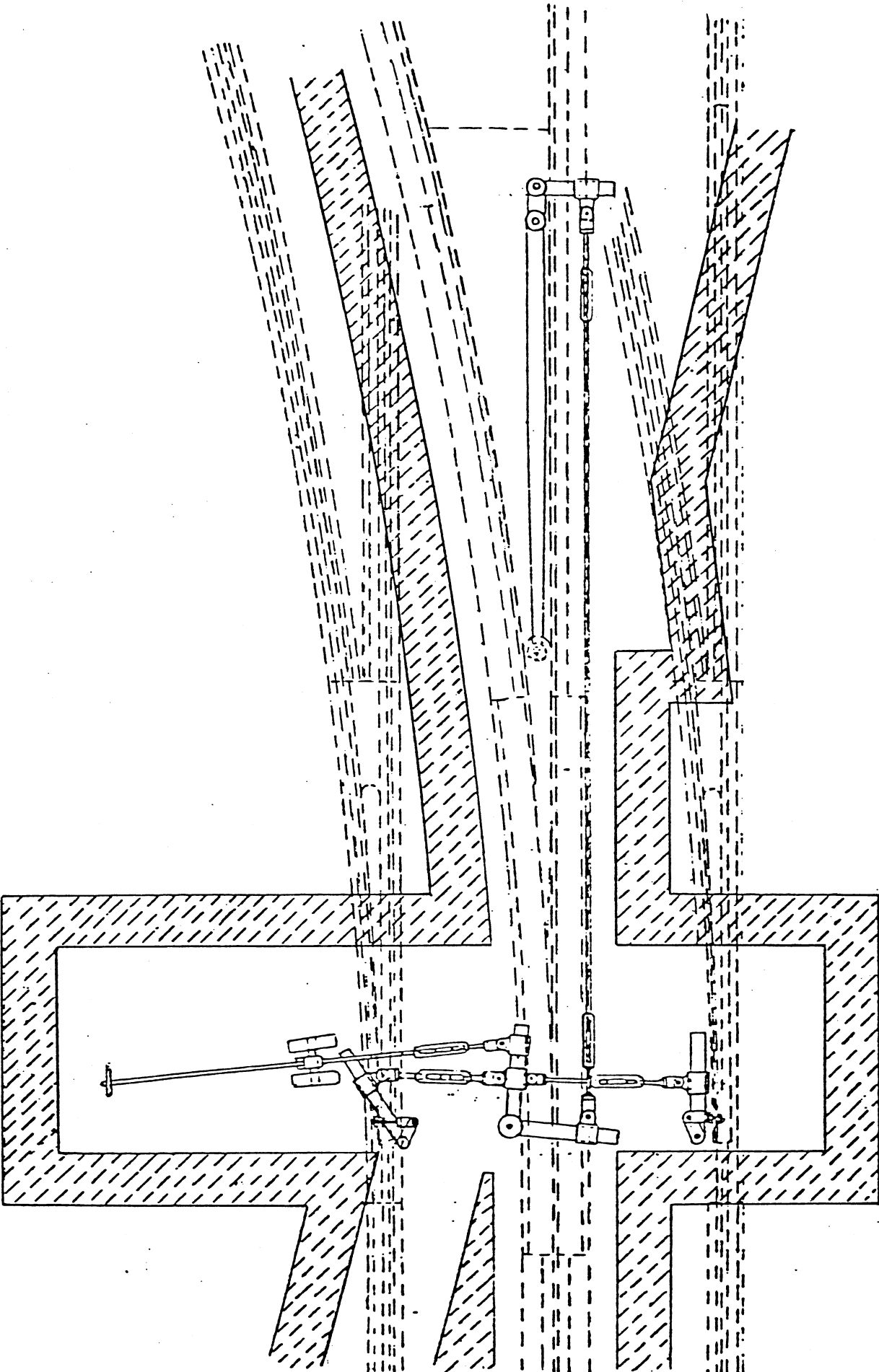

HAND OPERATED SWITCH GEAR

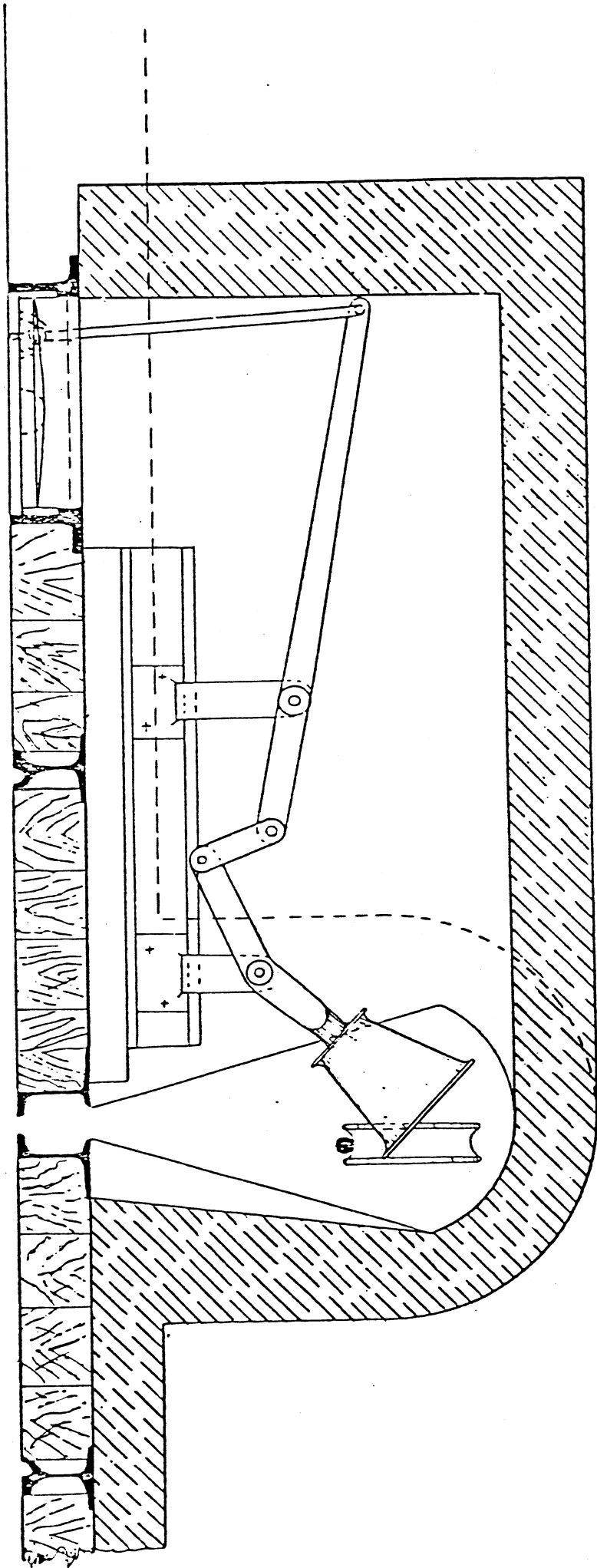

HAND PICK UP



19.10.18

FITZROY POWER HOUSE

FITZROY ROPE STRANDED

2700 FEET BUNCHED

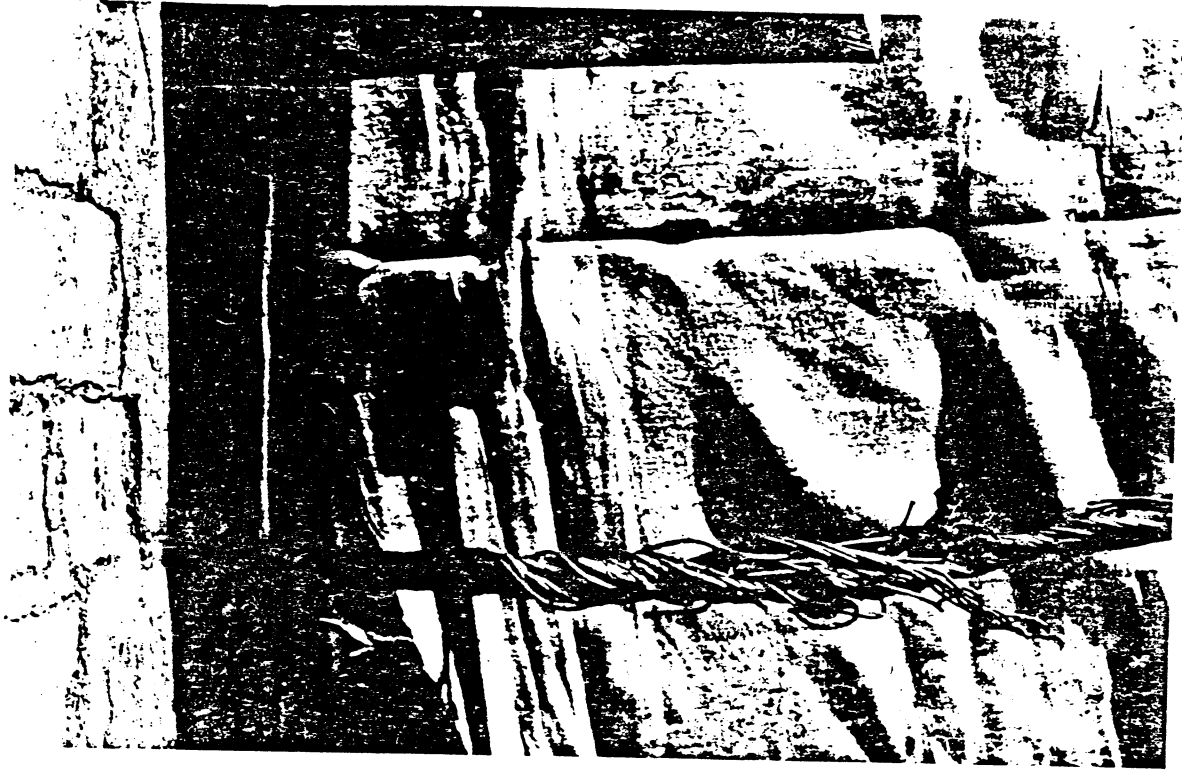

DOMAIN ROAD ROPE KINKED CORNER PARK STREET AND
DOMAIN ROAD UP TRACK; KINK CUT OUT AND ROPE
SPliced. (ONE STRAND CUT IN TWO, CORE CUT AND
DISPLACED, FIVE WIRES GONE IN THREE OTHER
STRANDS). STOP ONE HOUR

Note:- No.1 Splice Cut Out and No.2 Put In
On Account Of End Of Race.

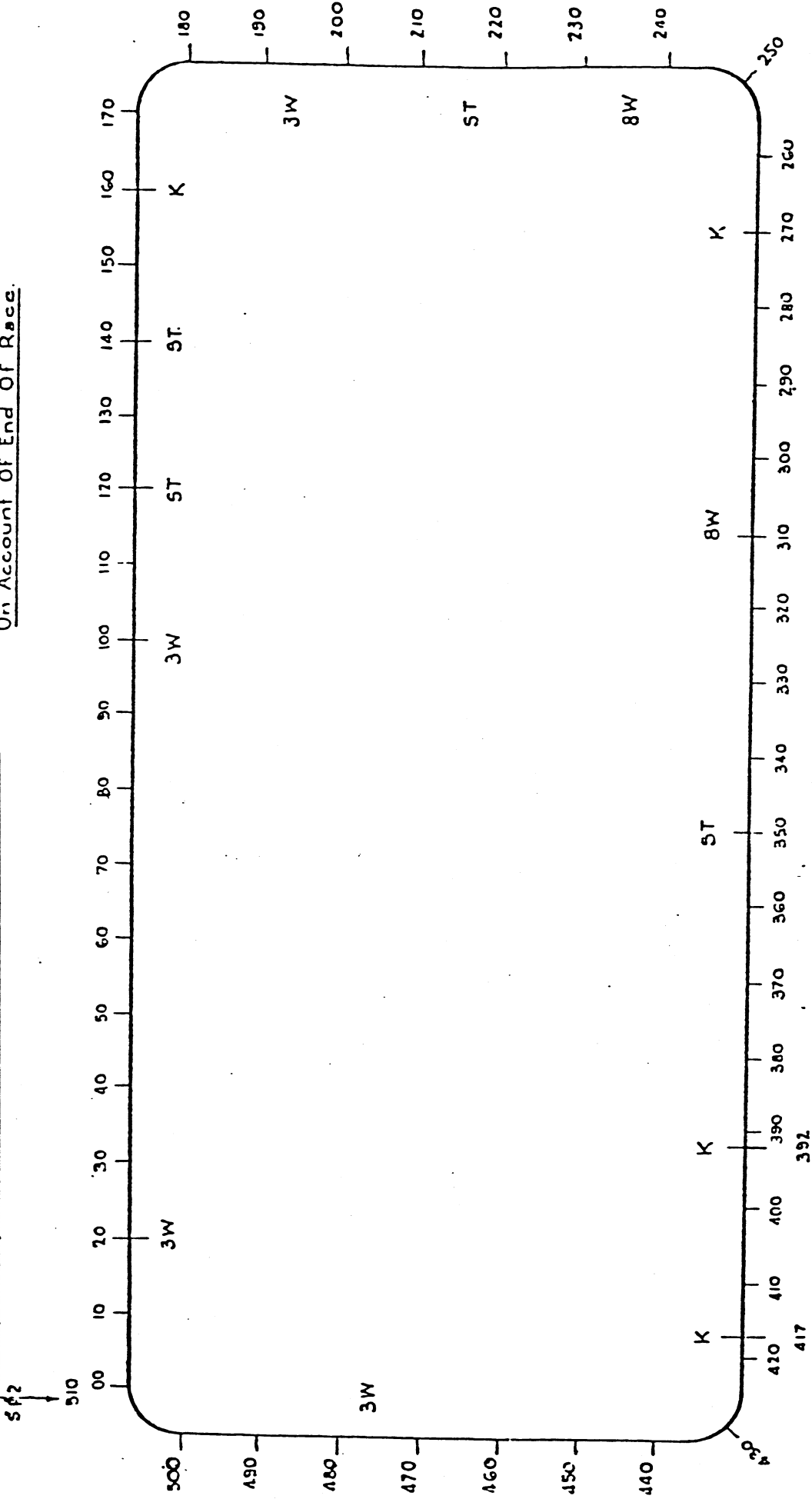

CLARENDON STREET ROPE N°41
 WHITE CROSS N°149
 WEEKS RUN 39
 REVS. 510

Contact held by light spring.
or weight over a pulley.
Broken by Strand.

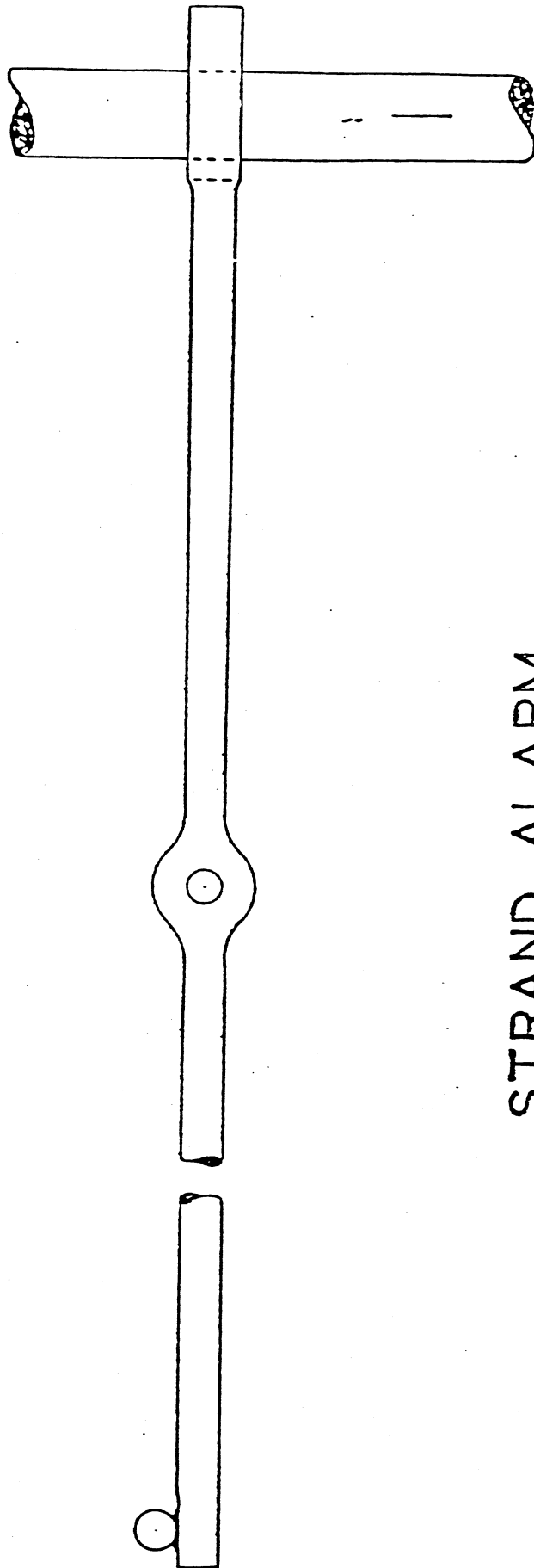
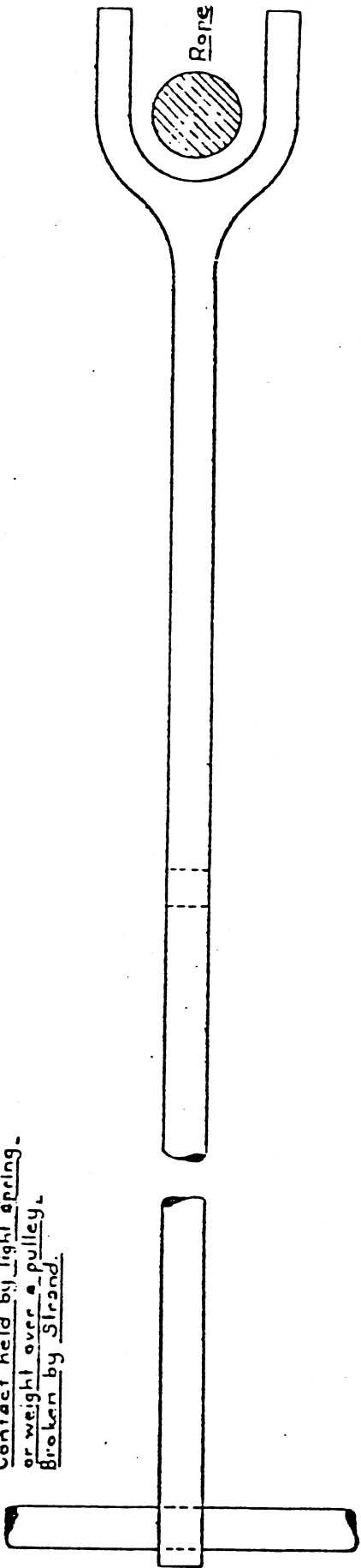

STRAND ALARM

SOUTH MELBOURNE POWER HOUSE

South Melbourne City } Part of
 rope number 32 } Old Clarendon St. No. 41
 White Cross No. 149 ex "Tropic"

(Ordered Invoiced 30 Nov. '21
 (received 1 Feb. '22

Driver 1 - 14" groove steel checks V - 1 in 4" - new 1 wood buttons.
 for run round rope makes 249 revs (43'10" per rev) - 10925' working length.

Wires per strand : Longa Lay

Rope contact on Driver 26'8"

Date	Lay	Cir. Part. in No. No.	Splices at Date	Stretch in at Date	Weeks in at Date	Packing in Driving Sheave	Strands put in Date	Rope No.	Revs.	Feet No.	Splice
June 17 10"	1-	3-11/16"	1-	1-4' 23/6-1	23/6-1	Steel	June 27	1	150	40	-
23/7 10"	J.N.P.	3-11/16"	No. 1	4-1'4" 14/7-4	14/7-4	Checks V-1 in 4	July 4	1	8	50	-
29/9 10"	J.J.H.	3 3/4"		8-1'4" 11/8-8	11/8-8	new wood bottoms.	Aug. 27	1	222	50	-
				12-1'4" 8/9-12	8/9-12		Aug. 18	1	109	50	-
				15- - 29/9-15	29/9-15		Aug. 19	1	9	40	-
							Sept 24	1	137	40	-
							Sept 26	1	215	40	-
							Sept 29	1	60	40	-
							Sept 29	1	241	45	-
							Sept 29	1	6	50	-
							Sept 29	1	87	45	-
							Sept 29	1	193	40	-
							Sept 29	1	6	45	-
							Sept 29	1	195	40	-
							Sept 29	1	6	40	-
							Sept 29	1	220	40	-
							Sept 29	1	137	40	-
							Sept 29	1	141	40	-
							Sept 29	1	47	40	-
							Sept 29	1	139	45	-
							Sept 29	1	7	40	-

Part of 1 Old Clarendon St. No. 41 - 39 wks. white Cross No. 149
 Put to work this morning (Sunday).
 Cut off wires: June 2/19, 9/20, 6/21, 11/23, 16/24, 11/27, 1/28, 8/29, 4/30.
 " " " " July 11/1, 4/3, 12/4, 5/5, 15/6, 5/7, 15/8, 13/11, 2/12, 12/13, 3/14, 12/15, 11/10, 7/19, 12/20, 16/22, 14/25, 14/27, 12/29.
 " " " " Aug. 16/1, 3/2, 10/3, 13/5, 13/8, 2/9, 16/10, 2/11, 13/12, 15/15
 " " " " 3/16, 11/17, 9/18, 1/21, 15/22, 6/23, 14/24, 2/25, 21/26, 2/20,
 " " " " 15/29, 4/30, 17/31, Sept. 10/1, 20/2, 18/5, 1/6, 19/7, 2/8, 16/9
 " " " " 2/11, 12/12, 4/13, 14/14, 4/15, 15/16, 5/10, 12/19, 3/20, 15/21
 " " " " 5/22, 16/23, 4/25, 17/26, 10/27, 16/28, 5/29.
 Cut off 758 wires during 76 nights

Kinked 23/6 @ 74 revs (slight); 21/7 @ 215 revs (badly 6' steel corr put in); 22/8 @ 5 revs (slight); 20/9 @ 93 revs (slight).
 Stops: 3/7-13 1/2 mins (strand); 18/8-1 min (wires); 18/9-1 1/2 mins (wires); 21/9-1 min (wires).

Extract ex Ropeman's Report Book : "Rope taken out had 24 repp. strands in it and is only fit for scrap." (Hayward)

Rope taken out after traffic over to-night (Saturday)

10"	3 1/4"	1	8'0"	15 wks.	Steel above	24	1045	1	80
-----	--------	---	------	---------	-------------	----	------	---	----

Rope speed - 12 1/2 miles per hour : Actual avg. - 12.62 miles

Avg. run for week (for traffic) say 1518 miles.

1 splice in all put in rope.

for fuller memoranda see ropeman's daily report book, (J.J. Hayward - head ropeman) (H. Hawkins - 2nd ropeman)

South Melbourne City No. 32 ran 15 weeks

Traffic	Miles	Hrs. mins.	Wks. i days
22775.07	1804.38	15 1 0	
Extra	363.15	43.30	- 1 -
As St. Melb. City 29.32	23138.22	1048. 8	15 1 0
As a whole in Clarendon St. No. 41	60337.27	4813.56	39 1 0
TOTAL	83475.49	6562. 4	54 1 0

Repairing strands used
 24 in rope - 1045'
 1 in splice - 80'
 25 - 1125'
 during 39 wks in Clarendon Street
 3 in rope - 123'
 1 in splice - 40'
 4 - 163'

Tension weight including bucket - 3 tons, 12 cwt., 2 lbs., 0 lbs.

No. 32 was an average rope it ran as Clarendon St. No. 41 - 39 weeks estimated first life 36 weeks. No. 32 did 15 weeks in South Melbourne City (estimate 13 wks and had 750 wires cut off during 76 night and 24 strands put in. It now goes to scrap.

WILLIAM R. POLLOCK
 Asst. Mech. Engr.

Test (H. Cross) - 68.3 tons sq. in. outer wires. 142, centre 143, 19.9 turns in 8" Rope. Strand - 1 1/2" cir., Lay 4 1/2", outer wires 3/16, 3/16, 3/16, centre .143.5 (iron) (strand only measured).
 Core of manilla. hard laid up, same way as rope, oiled. Lay 2 1/2", Cir 2".

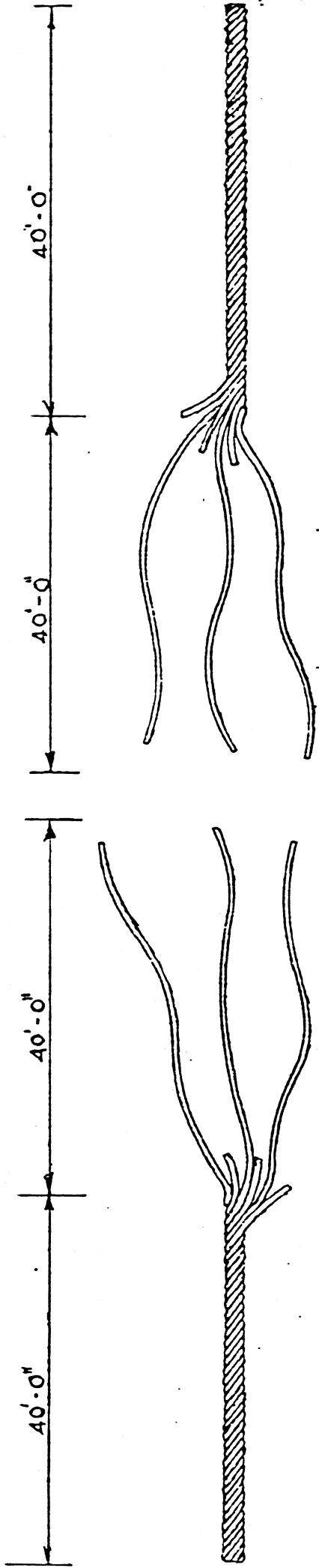

STAGE 1.

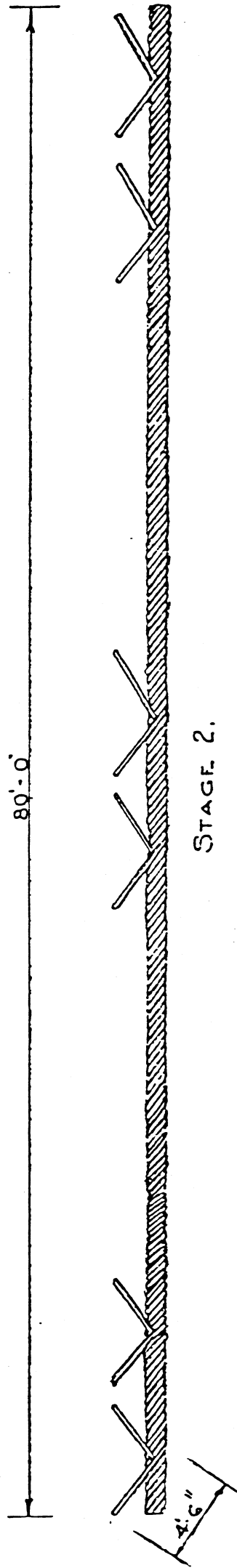

STAGE 2.

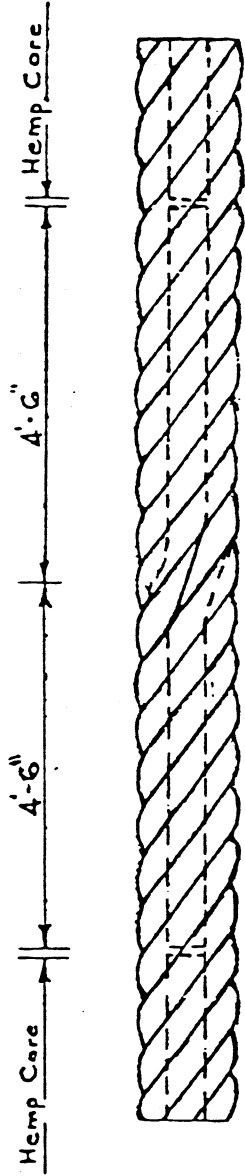

STAGE 3.

ROPE SPLICE

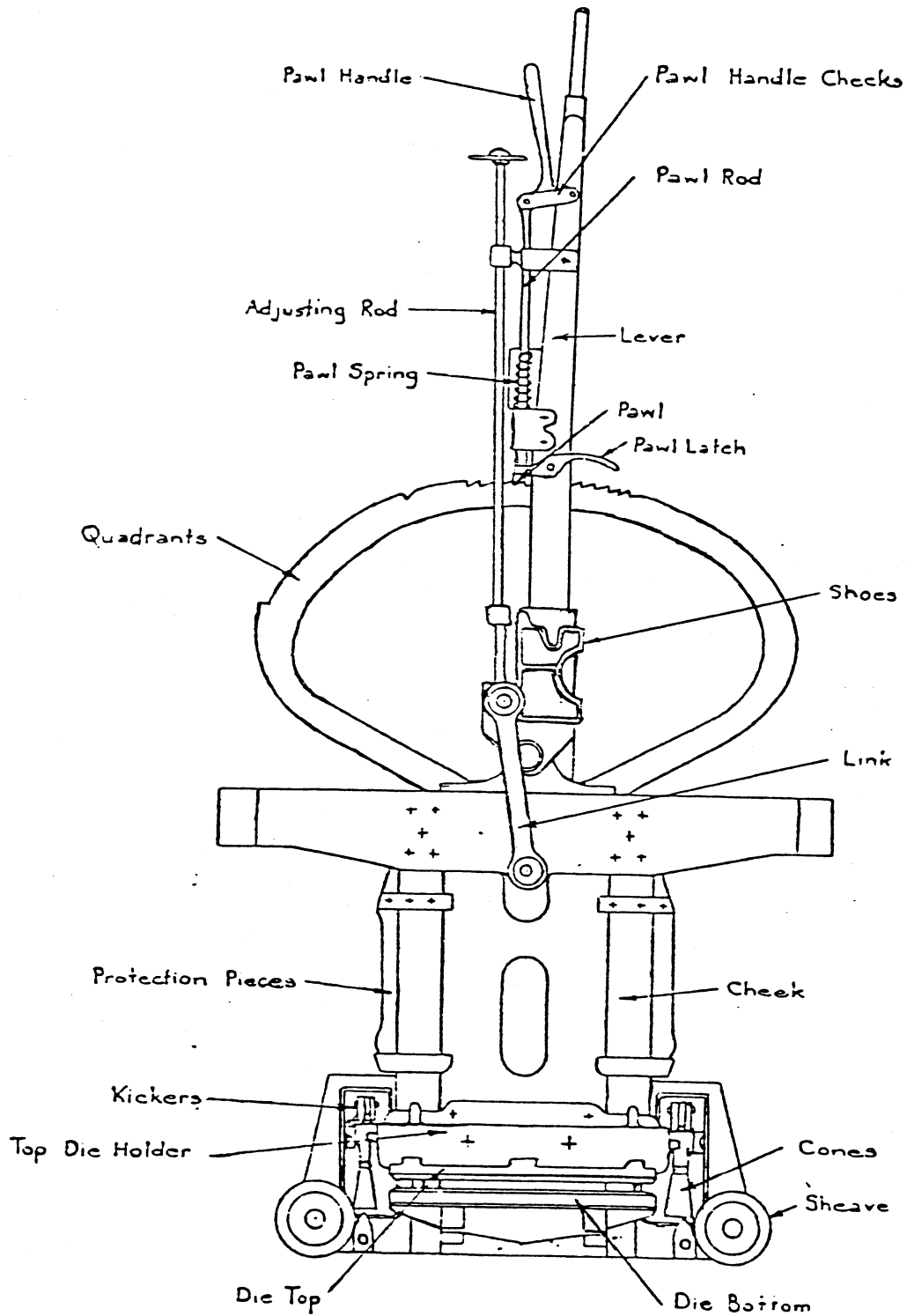

CABLE GRIP

CROWN PULLEY

Sheet No. 3
 METROPOLITAN
 ENGINEERING BOARD.

Plan showing dimensions

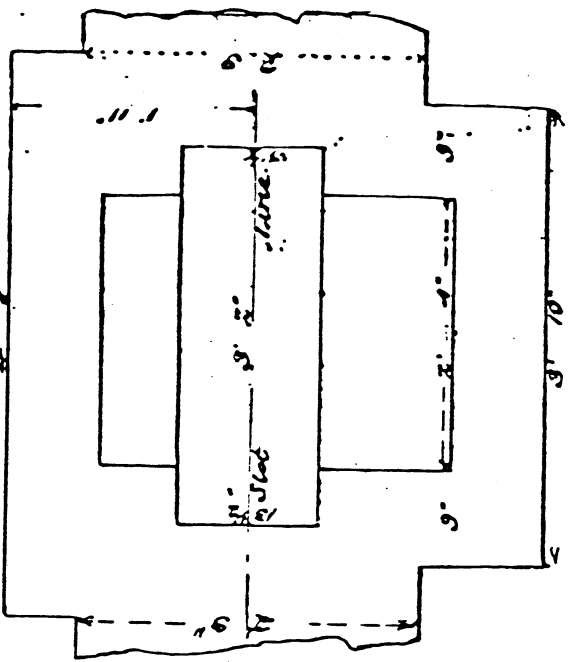

CROSS SECTION THROUGH THE PULLEY

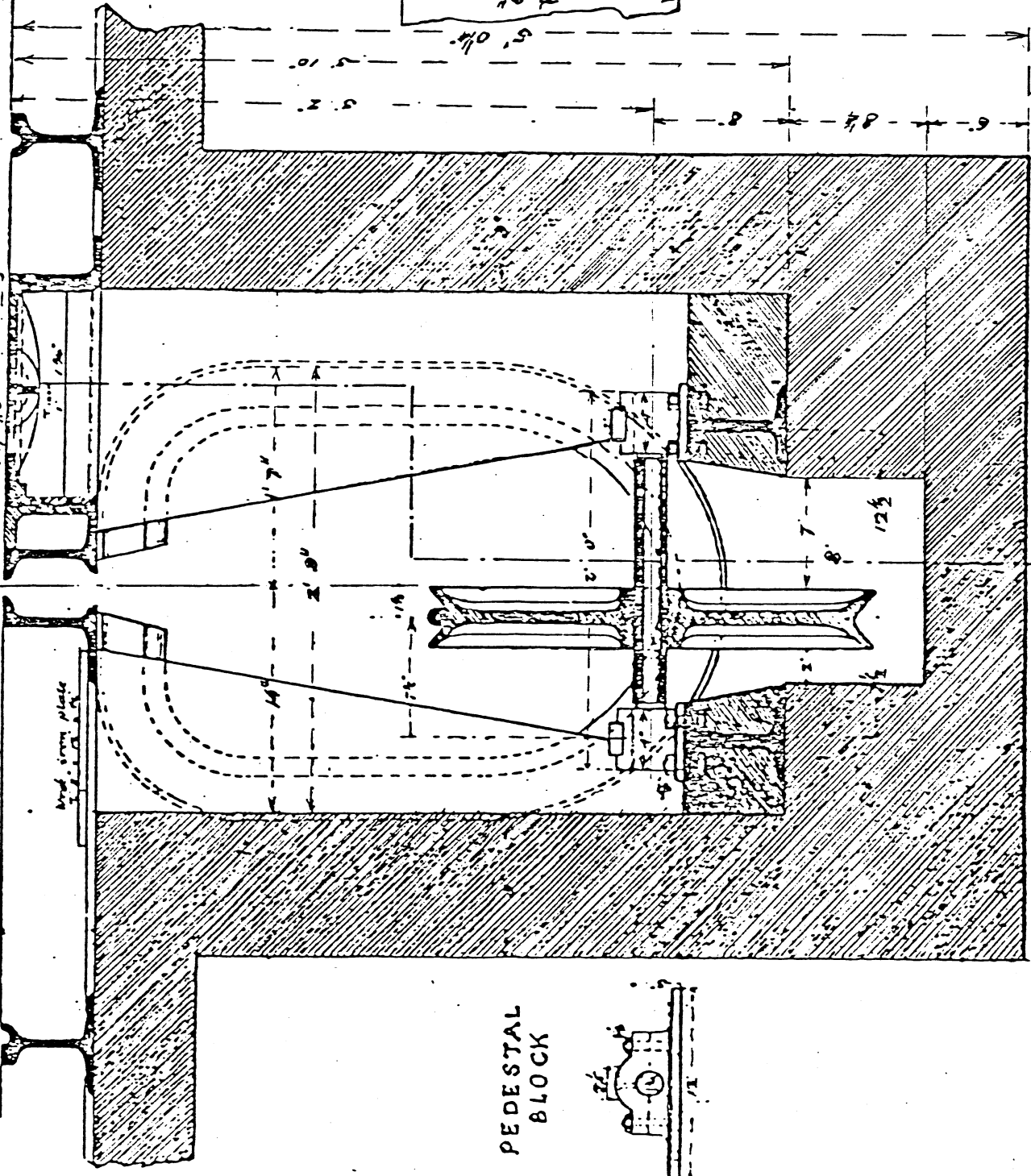

PEDESTAL
 BLOCK

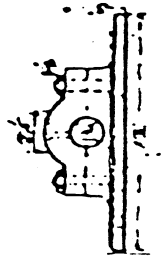

Scale - 1/2" = 1 Foot

