

INSTRUCTION PAMPHLET

No. T-5001

March, 1923

STRAIGHT-AIR
BRAKE
EQUIPMENT

WESTINGHOUSE TRACTION BRAKE CO.
PITTSBURGH, PA.

W. Hunter

**Straight-Air
Brake Equipment**

INSTRUCTION PAMPHLET

No. T-5001

MARCH, 1923

(SUPERSEDING ISSUE OF JULY, 1916)

COPYRIGHT, 1923, BY THE
WESTINGHOUSE TRACTION BRAKE CO.
PITTSBURGH, PA.

CONTENTS

Rules for Operating - - - - -	Page 7
Schedule SM-3 - - - - -	11
Parts of the Equipment - - - - -	12
Location, Adjustment and Operation of Parts	14
Operation of the Equipment - - - - -	26
Installation, Maintenance and Lubrication - -	30
Car Tests - - - - -	37
Hints to Motormen and Conductors - - - - -	39
General Hints - - - - -	40
Schedule SM-1 - - - - -	41
Operation of the Equipment - - - - -	44
Featherweight Equipment - - - - -	48

PREFACE

HOW TO STUDY THE AIR BRAKE

Because the air brake is a means of *car and train control*, a thorough understanding of its elementary functions and principles of operation on the part of railway men who have anything to do with car and train handling, either directly or indirectly, is not only the most important information that can be acquired but absolutely essential to the largest factor of safety and economy in the handling of traffic with minimum loss of life or damage to rolling stock.

A great deal of misapprehension and confusion of mind exists, however, in regard to the kind of practical air brake information *most essential* for different classes of railway employees.

Practical operating and mechanical railway officials in recent years have approved the following fundamental basis of approach to the subject of air brake education as most nearly meeting actual operating conditions and service requirements.

Motormen and Conductors

For this class of employes the *first* essential is the ability to skillfully *manipulate* the brake system as a whole, which involves merely a general knowledge of the functions and features obtainable in a given system, how to make preliminary car tests before starting out, and how to operate the brake valve to secure best results in train control under the different conditions that exist on any given road. It is of secondary and relatively minor

importance that operating employes of this class should know the internal workings of the various individual devices which make up the brake system or be familiar with the movement of parts and the detailed intricacies of various air pressures in different chambers, ports, passages, etc. Of course, the more comprehensive the air brake education of the employe, the more valuable his services to his road, but for the motorman, for example the ability to manipulate the brake valve with skill and judgment is of primary importance always. The section of this Instruction Book covered from pages 7 to 10, and pages 39 and 40, inclusive, is, therefore, intended primarily for this class of employes.

**Air Brake Foremen and Repairmen,
Employes who Adjust, Maintain, Repair and Test
Air Brake Apparatus**

For this class of employes who have to do primarily with internal construction, operation and proper functioning of moving parts of individual air brake devices, the study of ports, passages, chambers, air pressures and the whys and wherefores of internal operation is of first importance and a knowledge of manipulation secondary although desirable, of course, and to be encouraged so far as time and opportunity permit. The matter covering description, etc., from pages 14 to 38, is, therefore, intended, primarily for this class of railway employes.

**Superintendents, Master Mechanics, Air Brake In-
structors, Inspectors and Officials in Charge of
Air Brake Operation and Instruction Generally**

This class of railway officials and employes must understand the functions and features available in the brake equipment; should be familiar with our general recommendations as to manipulation and the specific instructions thereon as formulated and officially approved for a given road; should know the internal operation and functioning of individual devices; the maintenance of the apparatus in service; car tests for brake efficiency; tests for individual devices in repair shops; and, in general approved methods of organization and instruction for different classes of railroad employes in order to secure the largest practical results for the railway.

This Instruction Pamphlet has, therefore, been made sufficiently comprehensive throughout to meet all normal requirements of this class of officials. We feel very strongly that for those most concerned no effort is of greater practical benefit to the road served than that spent in the proper kind of air brake education and we are ready and willing, at all times, to assist in promoting these processes of education along practical lines in every way possible.

Price of this Instruction Pamphlet, single copies, 50 cents.

Westinghouse Traction Brake Company

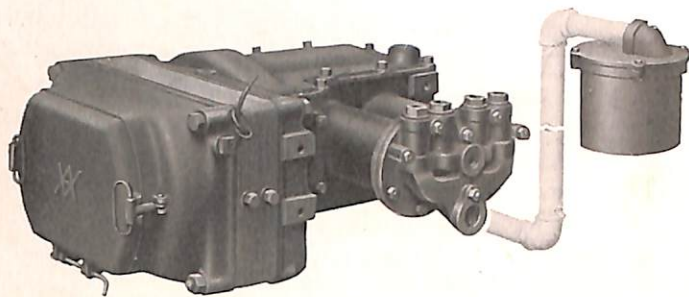

Fig. 1. DH-16 Motor Driven Air Compressor
with 8" Suction Strainer

STRAIGHT-AIR BRAKE EQUIPMENT

RULES FOR OPERATING

The following Rules are intended to cover in a condensed form the important instructions to be observed in handling this equipment in service. They are separated from the rest of the pamphlet so that they may be easily referred to. For a complete explanation of the operation of the equipment and description of the apparatus, the reader is referred to the body of the pamphlet.

Charging

Before starting the air compressor, *close* the drain cock in the main reservoir, and the whistle cut-out cock on the non-operative end of the car (if a whistle set is used).

Open the whistle cut-out cock in the operative end of the car (if a whistle set is used).

See that all hand brakes are fully released.

The fuse in the compressor circuit must be in place and "live".

Place a handle on the brake valve to be operated and move it to *Release and Running* position at the extreme left. Then start the compressor by closing the snap switches in the compressor circuit.

Do not attempt to move the car until the reservoir gage hand shows full main reservoir pressure.

Running

Keep the brake valve handle in *Slow Release* position when not being used.

In the event of sudden danger, move the brake valve handle quickly to *Emergency* position, at the extreme right, and leave it there until the car stops and the danger is past.

Service Application

To apply the brake for an ordinary stop, move the brake valve handle to *Service* position. When the desired brake cylinder pressure is obtained, move the brake valve handle back to *Lap* position, where it should remain until it is desired to release the brake or make a heavier application.

How heavy an application should be made, and whether a full application should be made at once or the brakes graduated on, depends upon the circumstances in each particular case, such as the speed and weight, condition of rail, grade, loading, kind of stop desired, and regard for the comfort of the passengers.

Because the retarding effect of any given brake cylinder pressure is greater at low than at high speeds, a heavy application at low speeds will result in an abrupt stop with perhaps discomfort to passengers or slid wheels. When running at high speeds, however, a heavy initial application should be made in order to obtain the most effective retardation possible when the momentum of the car is greatest.

If the brakes are applied lightly at first and the braking pressure increased as the speed of the car diminishes,

it not only makes a longer stop, but the high brake cylinder pressure at the end of the stop will be likely to produce a rough stop, perhaps slide the wheels and result in loss of time because of the necessity of waiting until this high cylinder pressure exhausts before the car can proceed.

The best possible stop will be made when the brakes are applied as hard, *at the very start*, as the speed, the conditions of the rail and comfort of passengers will permit, and then graduated off as the speed of the car is reduced, so that at the end of the stop little or no pressure remains in the brake cylinder.

To properly weigh all these varying factors in every stop becomes, after a little practice, an act of unconscious judgment. Careful attention to cause and effect at the very start and a real desire to improve are the most necessary qualifications in order to become expert in handling this or any other form of brake equipment.

Holding Brakes Applied

After an application has been made, the brake valve handle should be placed in *Lap* position and left there until it is desired either to make a heavier application or to release the brakes.

Never allow the brake valve handle to remain in Lap position, except while bringing the car to a stop, and it should not be allowed to remain in this position for a sufficient length of time to permit the cylinder leakage to diminish the braking force materially. If the car must be left standing for any length of time the hand brake should be set and the air brake released.

Release

To fully release the brakes, after any application, move the brake handle to *Quick Release* position. After the brakes have been released the handle should be moved to *Slow Release* position and left there at all times when the brakes are not in use.

To graduate or partially release the brakes, move the brake valve handle to *Slow Release* position for a moment then back to *Lap* position; repeat this operation as may be necessary until the car is brought to rest, only enough pressure being retained in the brake cylinder at the end of the stop to prevent the wheels from rolling.

With a very little practice, the motorman learns how long the handle should remain in *Slow Release* position to produce the results desired. Obviously this varies with the amount of brake cylinder pressure which it is desired to release.

Emergency

Should it become imperative to stop in the shortest possible time and distance, to save life or avoid accident, move the handle quickly from whatever position it may be in, to *Emergency* position, which is at the extreme right, and leave it there until the car stops and the danger is past.

Changing Ends

When changing from one end of the car to the other, remove the brake valve handle, and, after placing it on the brake valve at the other end of the car move it to *Slow Release* position. If a whistle set is used, open the whistle cut-out cock in the operative end and close that on the non-operative end.

SCHEDULE SM-3

NOTE—The reference numbers shown herein are for convenience only and are not to be used when ordering repair parts. See Part Catalogs giving Piece Numbers, etc.

This equipment is designed for use only on cars operated as single units in electric railway service.* Where it is necessary to use trailers or operate in trains of two or more units, the automatic or straight-air brake equipment with emergency feature (SME Equipment) should be used, as it is neither safe nor satisfactory to employ straight-air brakes for other than single-car operation.

This system covers the air brake in its simplest form. The fewest possible parts are necessary to establish a direct communication between the main reservoir and brake cylinder, thereby combining maximum simplicity with absolute certainty of operation. Another feature of considerable importance is extreme flexibility or the fine degree of accuracy with which the operator may increase or decrease the pressure in the brake cylinder.

*NOTE—We strongly recommend Straight Air Brake Equipment with Emergency Feature (SME Equipment) for single car operation on account of the much greater factor of safety provided by the automatic operation of this equipment in event of rupture of piping which with the simple Straight Air would result in loss of the brake.

PARTS OF THE EQUIPMENT

The following is a list of the operating parts which make up this equipment, (See Fig. 20), with a short description of each:

1. A *motor driven air compressor with suction strainer*, which furnishes the compressed air for use in the brake system.
2. A *main reservoir* to which the compressed air is delivered from the air compressor, where it is cooled and stored for use in applying the brake.
3. An *electric compressor governor*, which automatically controls the operation of the compressor between pre-determined minimum and maximum pressures.
4. A *fuse block, fuse*, and two *snap switches*, for the protection of air compressor against any excessive flow of current and enabling the current supply to be entirely cut off when desired.
5. A *safety valve*, which protects against excessive main reservoir pressure, in case the governor for any reason fails to stop the air compressor.
6. Two *single pointer air gages*, one at each end of the car show the pressure in the main reservoir.
7. Two *brake valves*, one at each end of the car, through which (a) the air is allowed to enter the brake cylinder for the purpose of applying the brakes; (b) the air in the brake cylinder is allowed to escape to the atmosphere when releasing the brakes; and (c) the flow of air to or from the brake cylinder may be prevented as when the brakes are being held applied in service.

8. Two *exhaust mufflers*, one for each brake valve, placed under the platform to deaden the sound of the brake valve exhaust.

9. A *brake cylinder*, with a piston and rod so connected through the brake levers and rods to the brake shoes that when the piston is forced outward by air pressure this force is transmitted through the rods and levers to the brake shoes and applies them to the wheels.

10. While not a part of the air brake apparatus proper, the car is sometimes equipped with two *air alarm whistles*, one at each end of the car to be used as a warning of approach, with the necessary *whistle valves* and *cut-out cocks*.

With this equipment, two lines of pipe are used. The *reservoir pipe*, connected to the main reservoir, furnishes the air supply to the controlling brake valve. The *straight-air application and release pipe* connects the controlling brake valve to the brake cylinder, and forms the means of communication by which the motorman, by proper manipulation of the brake valve handle, can operate the brakes by supplying air to, or exhausting it from, the brake cylinder.

LOCATION, ADJUSTMENT AND OPERATION OF PARTS

Fig. 20 shows diagrammatically the general arrangement of the parts of the equipment as applied to a motor car. In deciding upon the best location for the compressor, radiating pipe, reservoir, brake cylinder, etc., due regard must be had for the location of electrical apparatus under the car, the most efficient arrangement of foundation brake rigging possible, maximum cooling effect, and convenience of all apparatus for inspection. This latter point should receive special attention, as proper maintenance is of great importance in order to obtain all the advantages possible with any equipment and to prolong its life.

MOTOR DRIVEN AIR COMPRESSOR

Place the *air compressor*, Fig. 1, in such a location as to give easy access to the commutator, brush holders and oil filling fitting.

When the air compressor is operating, air is drawn into the cylinders through the suction strainer and past the inlet valves, compressed, and forced out past the discharge valves and through a radiating pipe to the *main reservoir*. (See Instruction Pamphlet No. T5002 for complete information covering the operation, maintenance, etc., of motor driven air compressors.)

SUCTION STRAINER

The *suction strainer* is connected by piping with the air inlet and is usually installed under the car and near the compressor. The 8" Suction Strainer is shown installed with the compressor in Fig. 1, and in section in Fig. 2. This strainer has been designed particularly to provide adequate and continued protection against entrance of dirt into the compressor where convenience of installation requires that the strainer be under the car.



Fig. 2. 8" Suction Strainer

The ample cross-sectional area provides for a slow rate of flow into and through the strainer, together with sufficient capacity to retain dirt and dust drawn into it without noticeable restriction to the flow of air. A compact layer of pulled curled hair prevents the passage through it of even the finest dust, the construction being such that all the air must filter through the entire

thickness of the bed of hair. The barrel of the strainer extends below the outer screen and protects it from the direct splash of mud or water. When the strainer is installed with the opening downward, as it should be, any dirt or dust which might be drawn into it when the compressor is running tends to be shaken out by the jolting of the moving car after the compressor stops.

MAIN RESERVOIR



Fig. 3. Main Reservoir

The *main reservoir* is used for the purpose of storing an abundant supply of compressed air to permit a prompt application of the brakes, also for cooling the air and depositing the moisture, oil, or other foreign matter carried into the reservoirs, before passing on to the brake system. To assist in this, the piping should be so installed as to drain into the reservoir. As an accumulation of water or other foreign matter is not only injurious to the reservoir, but is liable to seriously reduce its capacity, it should be drained at regular and frequent intervals by means of the reservoir drain cock.

Enameled reservoirs are strongly recommended on account of their durability and protection against corrosion, oxidation, etc., preserving a greater factor of safety than does the plain unenameled type. These reservoirs are enameled by a special process both inside and out.

ELECTRIC COMPRESSOR GOVERNOR

The Type S-6-A Electric Compressor Governor, Fig. 4, is now supplied with straight-air brake equipment, although the Types J and G-1-D are used in some cases. The governor is usually set for a 15-pound range, the actual pressures being determined by the operating con-

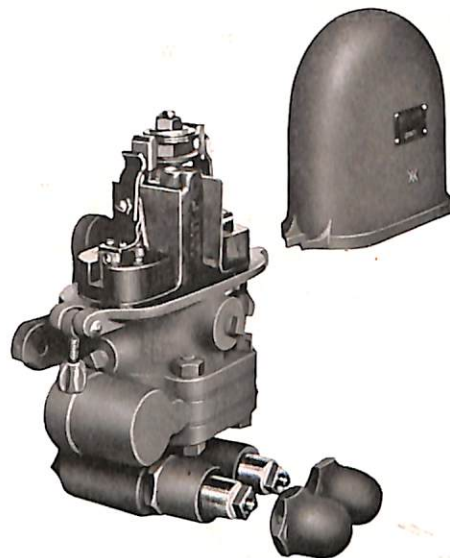

Fig. 4. S-6-A Electric Compressor Governor

ditions of each particular road. The standard and recommended cutting-in pressure is 50 pounds and cutting-out pressure 65 pounds. (See Instruction Pamphlet No. T5042 for complete information covering the operation, adjustment, etc., of electric compressor governors.)

The governor should be installed inside the car where it will be protected from dirt and the weather, and where it can be easily reached for inspection, adjustment or replacement.

SNAP SWITCHES AND FUSE BLOCK



Fig. 5. Snap Switch Fig. 6. Open Fuse Block

In the circuit between the trolley and governor are placed two *snap switches*, Fig. 5, and an *open fuse block* with *fuse*, Fig. 6. The snap switch affords a means of cutting off the current to the air compressor when so desired; while the fuse serves to protect the motor from a dangerous continued overload by blowing, and thus opening the circuit, when the amount of current flowing to the compressor exceeds the capacity of the fuse.

SAFETY VALVE

The Safety Valve, Fig. 7, should be installed in a branch pipe about one foot long taken from the discharge pipe no more than four feet from the compressor. The branch pipe should be so arranged as to drain toward the discharge pipe and the safety valve should be installed as near a vertical position as possible. It should be set at a pressure 10 pounds above the cutting-out point of the governor.

Valve 4 is held to its seat by the compression of spring 6 between the flanges of the stem and adjusting nut 7. When the air pressure below valve 4 is greater than the force exerted by the spring, it rises, and as a larger area is then exposed, its movement upward is very quick, being guided by the brass bush in the body 2. Two ports are drilled in this bush upward to the spring chamber; and eight outward through the body to the atmosphere, although only one of each of these is shown in the cut. As the valve moves upward, its lift is determined by the stem 5 striking cap nut 3. It closes the two vertical ports in the bush connecting the valve and spring chambers, and opens the lower ports to the atmosphere. As the air pressure below valve 4 decreases, and the compression of the spring forces the stem and valve downward, the valve restricts the lower ports to the atmosphere and opens those between the valve and spring chambers.

The discharge air pressure then has access to the spring chamber. This chamber is always connected to the atmosphere by eight small holes through the body, 2; the air from the valve chamber enters more rapidly

than it can escape through these holes, causing pressure to accumulate above the valve and assist the spring to close it with the "pop" action before mentioned.

The safety valve is adjusted by removing cap nut 3, and screwing up or down the adjusting nut 7. After the proper adjustment is made, cap nut 3 must be replaced and securely tightened, and the valve operated a few times. Particular attention must be given to see that the

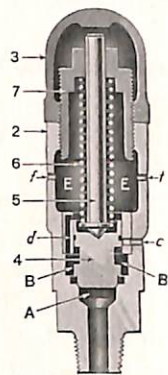

Fig. 7. E-1 Safety Valve

holes in the valve body are always open, and that they are *not changed in size*, especially the two upper holes.

AIR GAGE

The *Single Pointer Air Gage*, Fig. 8, is connected to the main reservoir pipe under the brake valve and should be installed in the direct line of vision of the motorman while operating the controller handle, and where it is not obscured in any way by intervening objects, or with strong light back of or near it.



Fig. 8. Air Gage

BRAKE VALVE*

The brake valves are located in the motorman's compartment at each end of the car. The PV-3 Brake Valve is of the piston valve type with a removable handle.

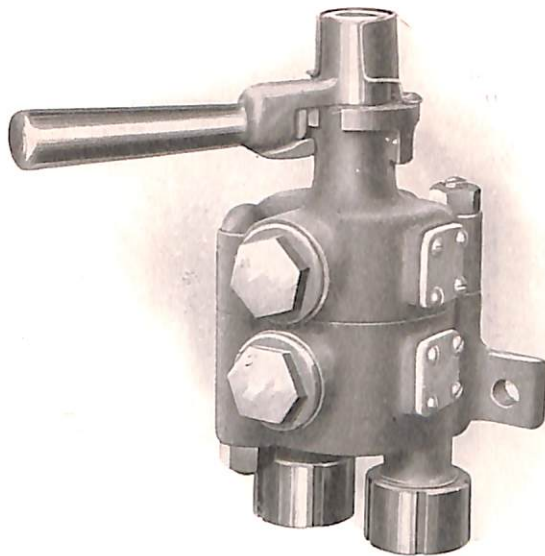

Fig. 9. PV-3 Brake Valve

*NOTE—Although not normally considered standard with the SM-3 Equipment, the SY and SX-2 Brake Valves are in service on some roads. The SY is of the slide valve type and the SX-2 (see Fig. 18, also operation of equipment on page 28) is of the rotary valve type, with no changes in operating characteristics from those of the PV-3 Brake Valve but differing, however, in certain details of construction.

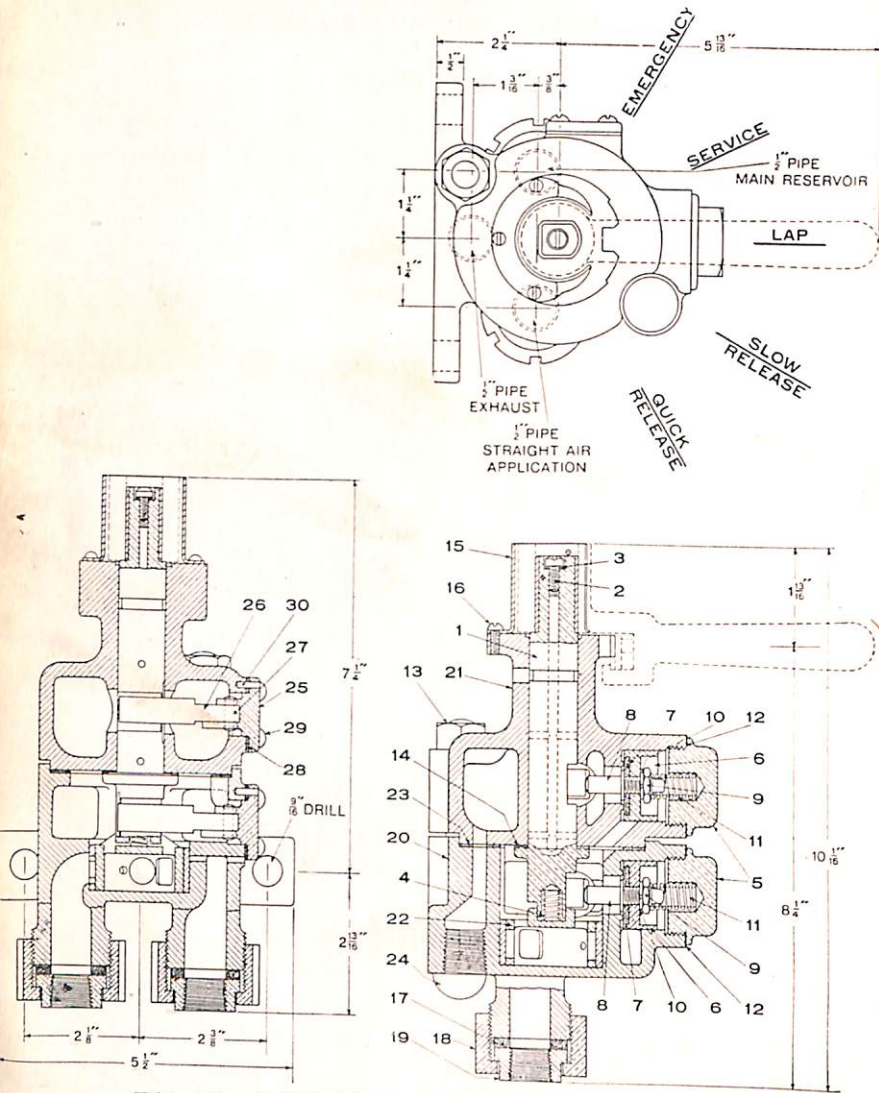

Fig. 10. PV-3 Brake Valve, Plan View and Vertical Sections

Three pipe connections are made to the lower portion or bracket as follows: straight-air application and release pipe, reservoir pipe, and exhaust pipe.

The different positions of the brake valve handle, in order from left to right, are:

1. *Quick Release* position in which the brake cylinder is connected to the exhaust.

2. *Slow Release* position in which the brake cylinder is connected to the exhaust through a restricted port.

3. *Lap* position in which all the ports are blanked except the exhaust, thus holding any pressure in the brake cylinder that may have been established therein. This is the only position in which the handle can be removed.

4. *Service* position in which connection is made from the reservoir pipe to the application and release pipe through a relatively small opening, thus admitting air to the brake cylinder and applying the brake.

5. *Emergency* position in which a large opening is made from the reservoir pipe to the application and release pipe, thereby admitting main reservoir pressure into the brake cylinder in the shortest possible time.

BRAKE CYLINDER

The *brake cylinder*, Fig. 10, should be located in such a manner that it is convenient for inspection work.

The piston, 3, has a hollow rod in which is a solid push rod, 14, attached to the levers of the foundation brake rigging. This allows the brakes to be applied by hand without moving the piston, but a pneumatic application forces out both hollow piston rod and push rod. The movement of the brake rigging must therefore be free from binding or undue friction, and adequate clearance provided for both hand brake and air brake systems, to insure that the push rod shall return fully home when a release is made.

The release spring, 9, forces the piston to release position when the air pressure is exhausted from the opposite side of the piston.

The packing leather, 7, is pressed against the cylinder wall by the packing expander, 8, and prevents the escape of air past the piston.

ALARM WHISTLES

The *alarm whistle valve* should be within easy reach of the motorman while operating the controller handle. The *alarm whistle*, *whistle valve* and *whistle cut-out cock* are connected directly to the main reservoir pipe.

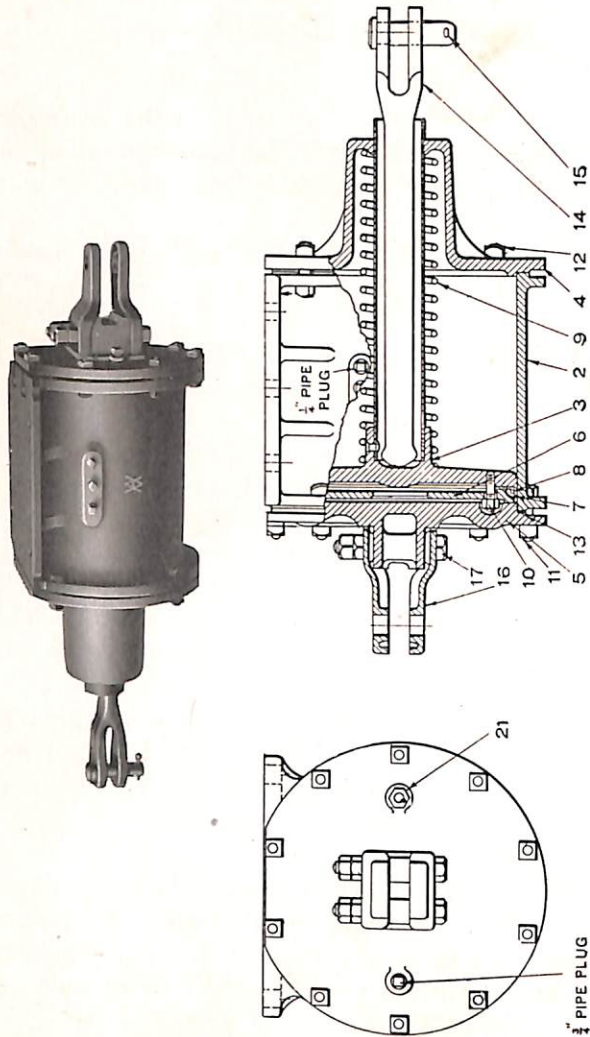

Fig. 11. Type S Brake Cylinder, Exterior and Sectional Views

OPERATION OF THE SM-3 EQUIPMENT

The relative positions of the various parts of the brake valves and the brake cylinder piston, for the different positions of the brake valve handle, are shown diagrammatically on the folders at the back of the pamphlet. The actual proportions and mechanical construction of the parts have been disregarded where necessary to make the connections and operation more easily understood.

STANDARD EQUIPMENT WITH PV-3 BRAKE VALVE

Running

Fig. 21 illustrates the equipment while running along the road with the brake fully released and the main reservoir charged. With the brake valve handle in either *Quick Release* or *Slow Release* positions, the brake cylinder is connected to the atmosphere. *Slow Release* position of the PV-3 Brake Valve is used as *Running* position, although in Fig. 21, the brake valve is shown in *Full Release* position.

Service

To apply the brake the handle of the brake valve is moved to *service* position, Fig. 22. In this position the admission valve (in bracket portion 20) is open, permitting main reservoir air in passage *a* to flow through

restricted port *l* of the graduating valve 22 and passage *g* to the brake cylinder, forcing the piston outward and applying the brake. The size of the graduating valve port is restricted in this position in order to cause a gradual increase of pressure in the brake cylinder.

Holding

When the desired brake cylinder pressure has been obtained, the brake valve handle should be placed in *Lap* position, Fig. 23. In this position all valves are closed, thus cutting off further flow of air to the brake cylinder.

Quick Release

When the brake valve handle is placed in *Quick Release* position, Fig. 21, air from the brake cylinder flows through passage *g*, port *b* of the graduating valve 22, past the release valve (in upper portion 21), and passage *e* to the exhaust pipe. The release spring acting on the opposite side of the brake cylinder piston then forces it back, thus releasing the brake shoes from the wheels.

Slow Release

The operation of the brake valve with the handle in *Slow Release* position is the same as in *Quick Release* position, Fig. 21, except that the small port *l* (also used in *Service* position) of the graduating valve 22 is open in *Slow Release*, thus permitting a more gradual reduction of brake cylinder pressure, than *Quick Release* position in which the larger port *b* is open. *Slow Release* is generally used as *Running* position.

Emergency

The *Emergency* position of the brake valve handle should be used only when it is necessary to stop the car within the shortest possible distance in order to avoid accident. In this position, Fig. 24, main reservoir air is admitted to the brake cylinder through passage *a*, past the admission valve (in bracket portion 20), through port *h* of graduating valve 22, and passage *g*. The size of port *h* in the graduating valve is such as to permit a rapid equalization of main reservoir and brake cylinder pressures.

EQUIPMENT WITH THE SX-2 BRAKE VALVE

Running

Fig. 25 illustrates the equipment while running along the road with brakes fully released and main reservoir charged.

Service

To apply the brakes the brake valve handle is moved to *Service* position, Fig. 26. In this position restricted port *l* in the rotary valve of the brake valve registers with port *g* in the seat, permitting main reservoir air in chamber A to flow through these ports to the brake cylinder, forcing the piston outward and applying the brakes.

Holding

When the desired brake cylinder pressure has been obtained, the brake valve handle should be placed in *Lap* position, Fig. 27. This blanks port *g* and cuts off further flow of air to the brake cylinder.

Release

When the brake valve handle is placed in *Release* position, Fig. 25, air from the brake cylinder flows back through passage *g* in the brake valve, ports *b* and *d* and cavity *c* in the rotary valve and passage *e* in the seat to the atmosphere. The release spring acting on the opposite side of the brake cylinder piston then forces it back and releases the brake shoes from the wheels.

Emergency

The *Emergency* position of the brake valve should be used only when it is necessary to stop the car within the shortest possible distance to avoid accident. In this position main reservoir air is admitted to the brake cylinder through passage *a* in the brake valve, thence through the large port *h* in the rotary valve and port *g* in the seat, Fig. 28, in consequence of which air flows quickly from the reservoir to the brake cylinder until both pressures become equalized.

INSTALLATION, MAINTENANCE AND LUBRICATION

Piping

All piping should be so installed that there are no pockets in which moisture can collect and freeze in cold weather. Before installing the brake valves, the pipes should be hammered to loosen the scale and dirt, have fins removed, and be thoroughly blown out to remove all this foreign matter. Bends should be used wherever possible instead of elbows. A suitable compound to make a tight joint should be applied on the male threaded portion only, and never in the socket. Do not use red or white lead. After piping is complete, all joints should be thoroughly tested under pressure with soap-suds and made air tight.

It is recommended that individually tested pipe fittings known as "Extra Quality Fittings" be used in connection with all air brake piping. These fittings are thoroughly tested under pressure and guaranteed not to leak; in addition, they are carefully threaded and finished so that the installation of pipe and fittings is carried out with the least amount of testing and substitutions in the way of refitting. Also, it is especially recommended that brass to iron seat unions be used. These insure air tight joints and greatly facilitate the removal of valves to which pipes are connected. Furthermore, the necessity for providing the ordinary gaskets and keeping account of same is obviated.

Twenty-five feet of radiating pipe should be installed between the compressor and the main reservoir, five feet or more of which, adjacent to the main reservoir to be 2 inch-pipe, the remainder to be the same as the compressor discharge. For obvious reasons, the reservoir and radiating pipe should be placed as low and as near the outside of the car as possible, and well removed from sources of heat, such as resistance grids, motors, etc.

Wiring

The *wiring* should be installed in a thorough manner, great precaution being taken to avoid the possibility of grounds developing after the car has been in service for a time. Whenever practicable, the wiring should be run inside the car, securely cleated in place, and must always be so located that it may not be damaged when the body is being jacked up. At exposed places underneath the car and particularly at those points where the wire comes in contact with iron, it must be covered with rubber tubing. The size of rubber insulated wire which we recommend for compressors up to and including 38 cu. ft. displacement when operating on standard railway voltage is No. 14 B. & S. gage. Although smaller sizes might do the work without excessive drop in voltage or danger of overheating, still they lack mechanical strength and a smaller size of wire than No. 14 is undesirable on this account. Under these conditions, the 50 ft. displacement compressor should be wired with No. 12 B. & S. gage.

The sequence in which the various parts should be connected is shown in Fig. 20, but the point at which the compressor circuit shall be tapped to the main trolley line is one to be determined in each individual case. We recommend connecting between the choke coil and circuit breaker in order to obtain lightning protection, but to be independent of the circuit breaker.

By tapping on the trolley line outside the main switches we overcome all disadvantages, and if the connection is made between the first main switch and the point where the light circuit is tapped off, *and the lamp circuits are turned on during storms*, a very efficient lightning arrester is provided. The better plan, of course, is to provide a separate arrester for the compressor circuit, which involves only a slight additional expense.

From the trolley connection, run the wire first to one compressor snap switch and then to the other, connecting them in series, and making sure that when they are open, their dials show the word "Off" and when closed "On"; thence through the fuse block to the governor where the connection may be made to whichever terminal is most convenient. From the remaining terminal run a wire to the motor where the connection must be made to the field lead. The other lead must be connected to the main motor ground wire; by this means a grounded field coil or lead can cause no damage to the armature. The positive wire leading to the motor, and the ground return from same should, under no circumstances, pass through the same hole or be cleated together, but should be kept three or more inches apart.

The compressor snap switches, one at each end, should be placed within easy reach of the motorman without necessitating his moving from his customary position.

The fuse block should be connected between the last snap switch and the governor. It ought not to be placed so that a screw driver or other implement is needed to remove or replace the fuse, but should be easily accessible, in a dry place, and well removed from any possible ground connections.

LUBRICATION

*Brake Cylinder

Fasten the piston sleeve and non-pressure head together with a nail through the hole provided in the sleeve or with a suitable clamp. Remove the nuts from non-pressure head bolts, then remove piston from the cylinder.

CLEANING CYLINDERS. Scrape the old lubricant from the cylinder wall and leakage groove and wipe these surfaces clean and dry. Kerosene may be used for assisting in cylinder cleaning but must be completely removed to prevent serious damage to the cylinder gaskets and the packing leather. If the cylinder wall is rusted, the rust should be removed with sand paper.

*NOTE—These instructions apply particularly to brake cylinders having leather packings. If WABCO Cups are used the general procedure should be followed except that no expander ring is needed, a generous supply of lubricant may be used, and kerosene employed for cleaning purposes without fear of damage to the packing cup.

CLEANING PISTON AND PACKING LEATHER. Remove expander ring from piston. Scrape old lubricant from the metal part and packing leather and wipe all surfaces clean and dry. Leather should be carefully examined and should be renewed if brittle, thin at any point, cut, cracked, or otherwise defective. Examine piston and follower plate for cracks and tighten up follower plate nuts.

PACKING LEATHER EXPANDING RINGS. Replace the packing leather expander ring with one which has been checked in a special gage designed for this purpose; the displaced ring to be returned to the shop for checking.

APPLYING NEW LEATHERS. Examine follower studs for tightness in the piston. Place the leather centrally on the piston, flesh side against the piston. Place the follower in position. Apply the nuts, bringing them in contact with the follower without tightening. Then draw them down uniformly.

APPLICATION OF LUBRICANT. Apply a thin coating of brake cylinder lubricant to the wall of the cylinder with a brush. Fill the expander ring groove, at the same time coating the inside of the leather and place the expander ring in position.

ASSEMBLING. The piston should be stood on end, with the top edge or flat side of the non-pressure head flange and the opening of the expander ring toward the workman. With the piston in this position, enter it into the cylinder. The sleeve or rod should then be slowly raised and the piston moved into the cylinder until the upper portion of the leather engages the cylinder wall. Form this portion of the leather into the cylinder with

a dull edge, round cornered, putty knife or similar instrument, while the sleeve or rod is being gradually raised, taking special care not to crimp or otherwise damage the leather. Then pull upward and outward on the sleeve or rod until it is in horizontal position. Push the piston to its release position and then raise the sleeve or rod to the top of the cylinder to determine whether the expander is in its proper position, which will be indicated by freedom of movement.

When assembling pistons in brake cylinders in other than the customary location below the underframe, the methods employed must be changed as required to produce similar results.

Brake Valve

Graphite grease is recommended for use on the brake valve rotary valve whenever it can be conveniently applied, as when assembling the device after overhauling, repairs, etc. However, as graphite grease cannot be used conveniently for lubricating the valve after it is assembled, a good grade of oil should be used in such cases.

PISTON TRAVEL

The travel of the piston should be adjusted to 4 inches (standing) as nearly as practicable. This is important, for if the piston travel is too short a high braking power will be obtained when only a low braking power is desired, a given brake cylinder pressure will be obtained more quickly, and the time in which the motorman can perform the operation is greatly reduced. On the other

hand, if the piston travel is too long there is danger of the piston striking the cylinder head or fouling of the levers; besides the air consumption is excessive.

The correct operation of the brakes can be secured only by maintaining a uniform piston travel. The increase in the slack of brake rigging, due to the wearing away of brake shoes, must be constantly watched and taken up by means provided in the brake rigging, thereby maintaining the piston travel as nearly uniform as possible. By far the best means for accomplishing this is to install, in all cases where possible, the Automatic Slack Adjuster. Where this is not done, proper inspection and adjustment must be made at sufficiently frequent intervals to prevent any material increase in piston travel. As this inspection and adjustment has to be made while the car is standing, it must be remembered that running travel in traction service is generally from $\frac{1}{2}$ " to 1" longer than standing travel, so that if a 5" running travel is desired, the standing travel should be adjusted to about 4". If the Automatic Slack Adjuster is used, its pipe should be connected with the brake cylinder at the hole located $5\frac{3}{8}$ " from the pressure head.

Piston travel should never be altered to obtain sufficient shoe clearance. This should be obtained by using a brake cylinder of proper size for the brake force to be developed, and through proper porportioning of the foundation brake rigging. When inserting new shoes to replace those worn out, the brake slack should be let out first, and the piston travel adjusted properly after the new shoes are in place.

CAR TESTS

In preparing the car for service and before making the following tests follow carefully the rules given under the heading, *Charging*, page 7.

See that the hand brake is released. The fuse in the compressor circuit must be in place and "live". Then close the compressor switches and start the compressor.

Test No. 1: When the system is charged and the governor stops the compressor, apply the brakes in service and return the handle to *Lap* position. The brake inspector or conductor should then proceed at once to the side of the car noting whether the piston has moved out such distance as to indicate that the brakes are properly applied. If the brake releases after the service application it may be caused by a brake valve not being properly "lapped", by a leaky valve, or brake cylinder packing leather. If any improper operation is observed during this test it should be corrected before proceeding with the next test.

Test No. 2: Following Test No. 1, after having noted that the brakes apply after a service application, release the brakes by placing the brake valve handle in *Full Release* position. Leaving the handle in this position, the brake inspector should return to the side of the car, examining the push rod to see that it has moved back to "full release" and that all brake shoes hang free from the wheels.

Test No. 3: While it is ordinarily safe to assume that the brakes will apply on an emergency application if they apply satisfactorily in service test No. 1, yet the brakes should occasionally be tested by making an emergency application to make sure that no obscure causes exist which would interfere with this most important feature of the brake.

HINTS TO MOTORMEN AND CONDUCTORS

CUTTING OUT BRAKES. It is very important not to cut out the power brake unless it is absolutely impossible to operate it safely. Small leaks or temporary inconvenience are not sufficient cause for cutting out the brakes.

RAIL SANDING. Whenever it is necessary to sand the rails, this should be done, if practicable, before the brakes are applied, for the reason that if the brakes are set and the wheels begin to slide, the application of sand will not—in all probability—cause them to revolve again, and flat spots are almost sure to result. In such event the best practice is to release the brake slightly at the moment of applying the sand, after which a much higher brake cylinder pressure can be used without causing wheel sliding. If sand is used, the rails should be well and continuously sanded until the stop is made or the brakes released.

GENERAL HINTS

To gain time, adapt application of brakes to speed. For example, for high speeds make a full application and graduate off when a short distance from the stop. To handle cars smoothly, make application heavy and soon enough so that if held on, the car would stop a car length or so short of the mark. Then as the stop or mark is approached, graduate the pressure out of the brake cylinder so that little remains when the stop is made. If on a level, complete the release; if on a grade, hold until the signal to start is given, then release. As the pressure has been graduated down so that little remains in the cylinder, it will be seen that the start can be made promptly.

We recommend that all apparatus requiring repairs of any consequence be returned to our shops for that purpose. Our facilities for doing this work are of the best, and we can therefore do it more quickly and accurately, at a lower cost and guarantee better satisfaction than where it is handled by other shops not so well equipped. Furthermore, it is of the utmost importance that the manufacturers' standards be not departed from if the parts of apparatus are to be perfectly interchangeable.

SCHEDULE SM-1

The SM-1 equipment is an obsolete non-standard equipment now superseded by the SM-3 equipment, although a number of them are still in service. Its operative features are the same as those of the SM-3 equipment, and the instructions, etc., given hereinbefore will apply to it as well. The following parts are different:



Fig. 12. SJ Brake Valve

1. The *SJ Brake Valve*, Figs. 12 and 13, is of the slide valve type operated by a rack and pinion, having a duplex gage mounted on top, indicating main reservoir and brake cylinder pressure. The pipe connections are marked as follows: TP, application and release pipe; Res., reservoir pipe; EXH, exhaust pipe. The handle positions are the same as those of the PV-3, except that there is no *Slow Release* position.

2. The J Governor, Fig. 14, which is fully described in Instruction Pamphlet T-5042.

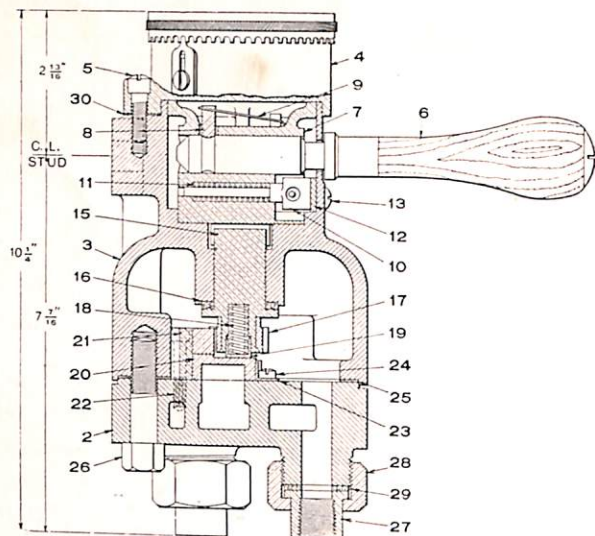
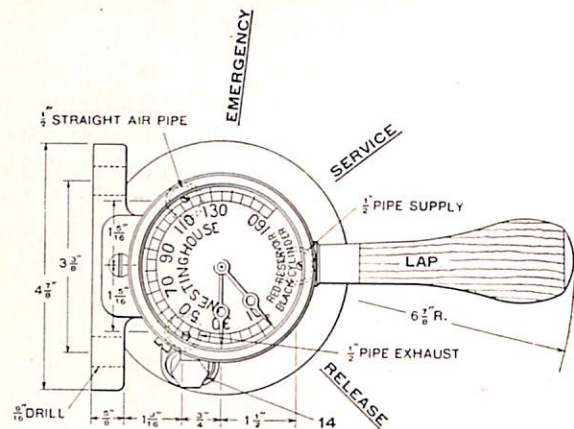

Fig. 13. SJ Brake Valve, plan and vertical section

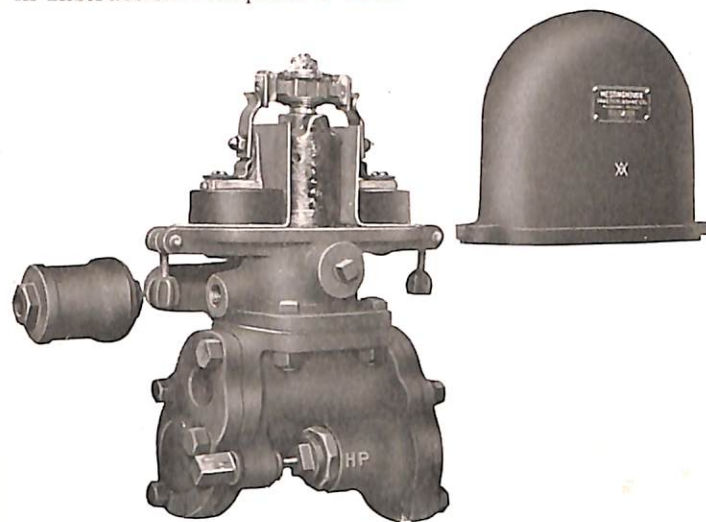

Fig. 14. Type J Electric Compressor Governor

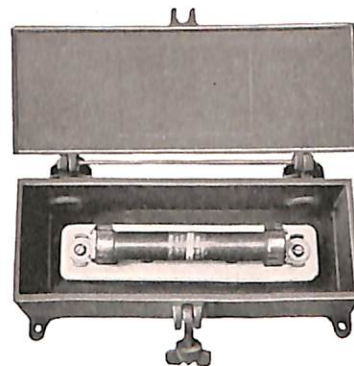

Fig. 15. Fuse Box with enclosed fuse

3. The Fuse Box, Fig. 15, which is used in place of the open fuse block.

OPERATION OF THE SM-1 EQUIPMENT

Figs. 29, 30, 31 and 32, show in a purely diagrammatic way the relations of the various parts to one another for the different positions of the brake valve handle. The actual proportions and mechanical construction of the parts have been disregarded where necessary to make the connections and operations more easily understood.

Running

Fig. 29 illustrates the equipment while running along the road with brakes fully released and main reservoir charged.

Service

To apply the brakes, the brake valve handle is moved to *Service* position, Fig. 30. In this position port *h* in the slide valve seat of the brake valve is uncovered, permitting main reservoir air in chamber A to flow through port *h* and passage *g* to the brake cylinder, forcing the piston outward and applying the brakes.

Holding

When the desired brake cylinder pressure has been obtained, the brake valve handle should be placed in *Lap* position, Fig. 31. This blanks port *h* and cuts off further flow of air to the brake cylinder.

Release

When the brake valve handle is placed in *Release* position, Fig. 29, air from the brake cylinder flows back through port *g* in the brake valve, cavity *c* in the slide valve and port *e* to the atmosphere. The release spring acting on the opposite side of the brake cylinder piston then forces it back and releases the brake shoes from the wheels.

Emergency

The *Emergency* position of the brake valve should be used only when it is necessary to stop the car within the shortest possible distance to avoid accident. In this position main reservoir air is admitted to the brake cylinder through two ports, *g* and *h* in the slide valve seat, Fig. 32, in consequence of which air flows quickly from the reservoir to the brake cylinder.

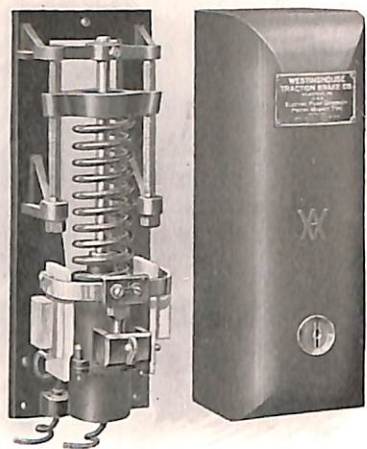

Fig. 16. G-1-D Electric Compressor Governor

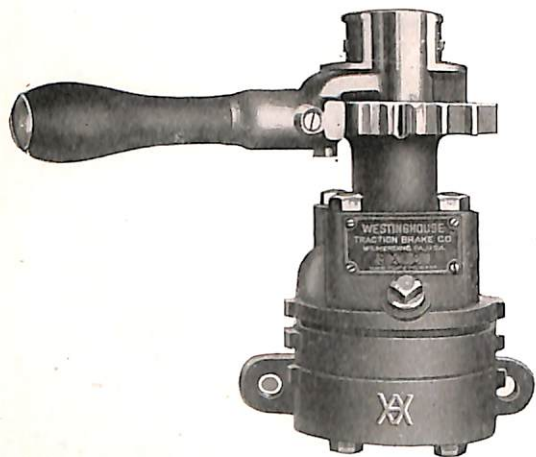

Fig. 17. SX-2 Brake Valve

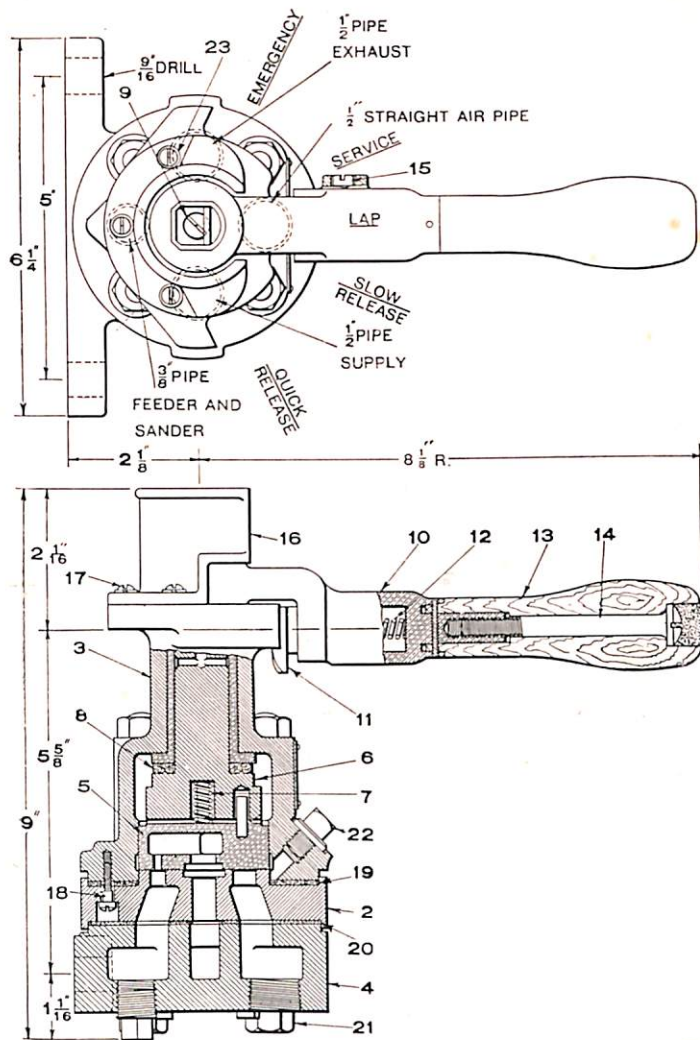

Fig. 18. SX-2 Brake Valve plan and vertical section

"FEATHERWEIGHT" EQUIPMENT

The Featherweight straight-air brake equipment is no longer considered standard, having been superseded by the SM-3 equipment.

The following parts of the Featherweight equipment are different from those now supplied with schedule SM-3.

1. *G-1-D Electric Compressor Governor*, Fig. 16, which is fully described in Instruction Pamphlet T5042.
2. *SX-2 Brake Valve*, Figs. 17 and 18, see note on page 21.

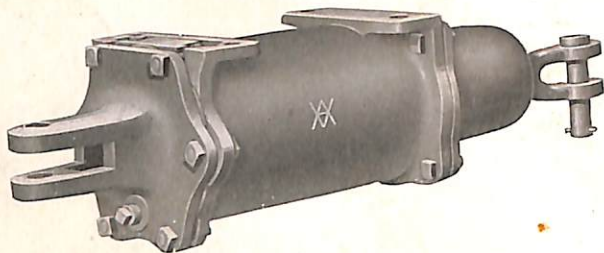
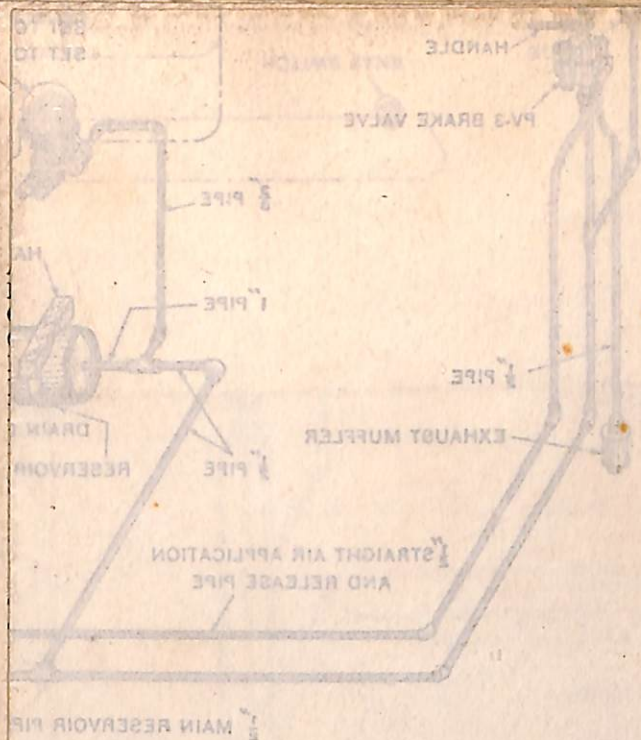

Fig. 19. "Featherweight" Type S Brake Cylinder

3. *Featherweight Type S Brake Cylinder*, Fig. 19, which is a modification of the standard Type S wherein special attention was given to the reduction of weight.
4. *Two Main Reservoirs*, of lighter material than standard and so constructed as to insure minimum weight.

The instructions covering the operation of the SM-3 also apply for the operation of the Featherweight equipment.



NOTE:
 (1) 25 FT. OF PIPE
 FIVE FT. OR MORE
 RESERVOIR TO
 REMAINDER TO
 CHANGE AT COU

Westinghouse Traction Brake Company

Pittsburgh, Pa., U. S. A.

WORKS AT WILMERDING, PA.

OFFICES:

ATLANTA	Candler Building
BOSTON	Exchange Building
CHICAGO	Railway Exchange Building
COLUMBUS	50 South Third Street
DENVER	Gas and Electric Building
HOUSTON, TEXAS	4802 Main Street
LOS ANGELES	Pacific Electric Building
MEXICO CITY, MEXICO	4a Puente de Alvarado, No. 100
NEW YORK	165 Broadway
ST. LOUIS	Broadway and Tyler Street
ST. PAUL	Endicott Building
SALT LAKE CITY	McIntyre Building
SAN FRANCISCO	Southern Pacific Building
SEATTLE	Securities Building
TOKYO, JAPAN	644 Marunouchi Building, Marunouchi
TOPEKA	Columbian Building
WASHINGTON, D. C.	Munsey Building



ASSOCIATED COMPANIES:

WESTINGHOUSE AIR BRAKE COMPANY, Pittsburgh, Pa.	CANADIAN WESTINGHOUSE COMPANY, LTD., Hamilton, Ontario, Canada.
THE AMERICAN BRAKE COMPANY, St. Louis, Mo.	SOCIÉTÉ ANONYME WESTINGHOUSE, Petrograd, Russia.
THE WESTINGHOUSE BRAKE & SAXBY SIGNAL COMPANY, LTD., London, England.	COMPAGNIE DES FREINS, WESTINGHOUSE, Sevran, France.
WESTINGHOUSE PACIFIC COAST BRAKE COMPANY, Emeryville, Calif.	COMPAGNIA ITALIANA WESTINGHOUSE DEI FRENI, Turin, Italy.
WESTINGHOUSE BRAKE COMPANY OF AUSTRALASIA, LTD., Concord West, New South Wales, Australia.	WESTINGHOUSE BREMSSEN GESELLSCHAFT, m. b. H., Hanover, Germany.

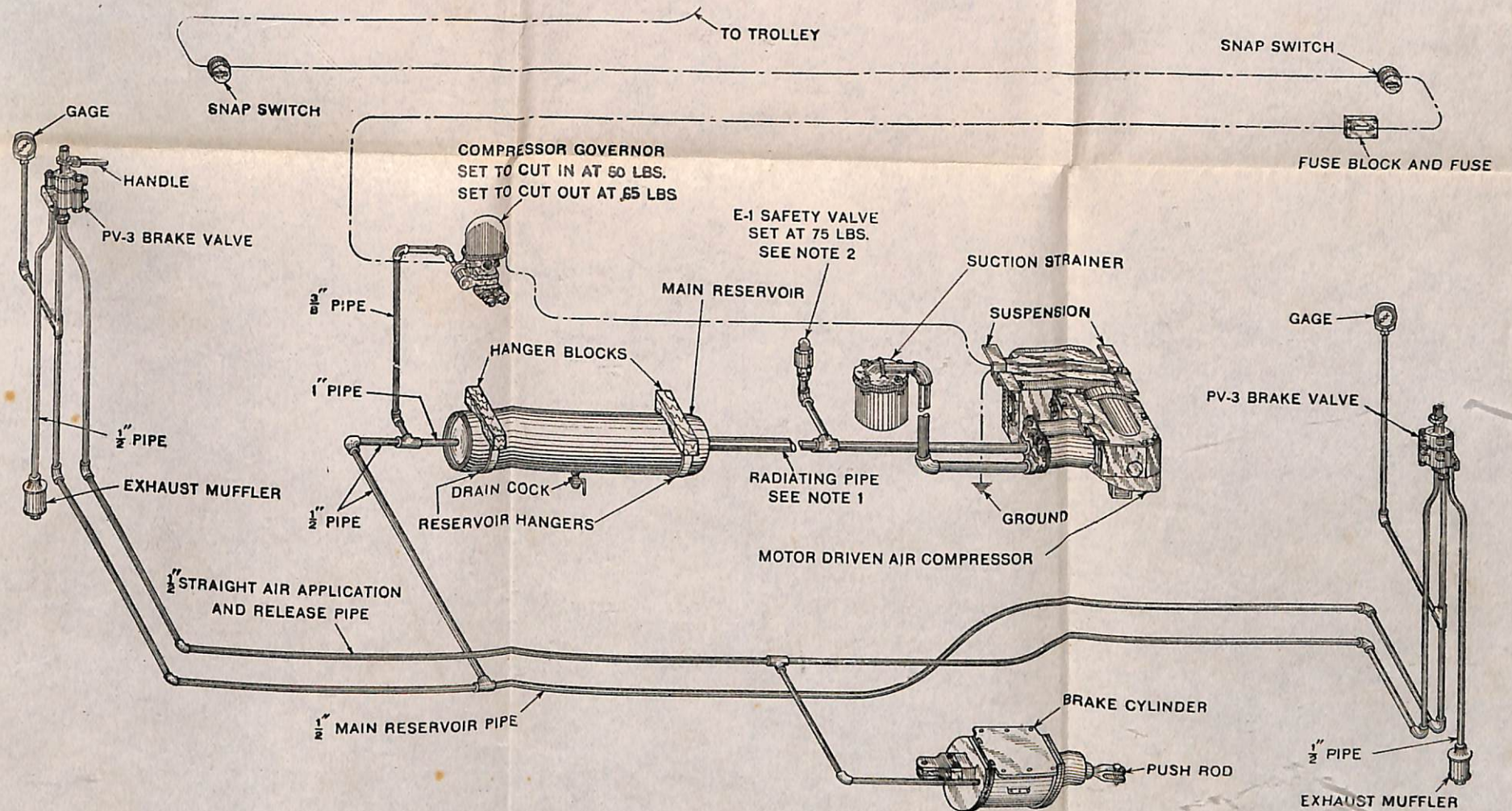

NOTES:

- (1) 25 FT. OF RADIATING PIPE OF WHICH FIVE FT. OR MORE ADJACENT TO MAIN RESERVOIR TO BE 2 INCHES AND THE REMAINDER TO BE THE SIZE OF DISCHARGE AT COMPRESSOR
- (2) SAFETY VALVE TO BE INSTALLED IN BRANCH PIPE ABOUT 1 FT. LONG, TAKEN FROM THE DISCHARGE PIPE ABOUT 4 FT. FROM THE COMPRESSOR. THE BRANCH PIPE TO BE SO ARRANGED AS TO DRAIN TOWARD THE TEE AND THE SAFETY VALVE TO BE IN VERTICAL POSITION.

Fig. 20. SM-3 Straight-Air Brake Equipment, Isometric Piping Diagram

Fig. 50 2473 Straight-Air Brake Equipment Isometric Piping Diagram

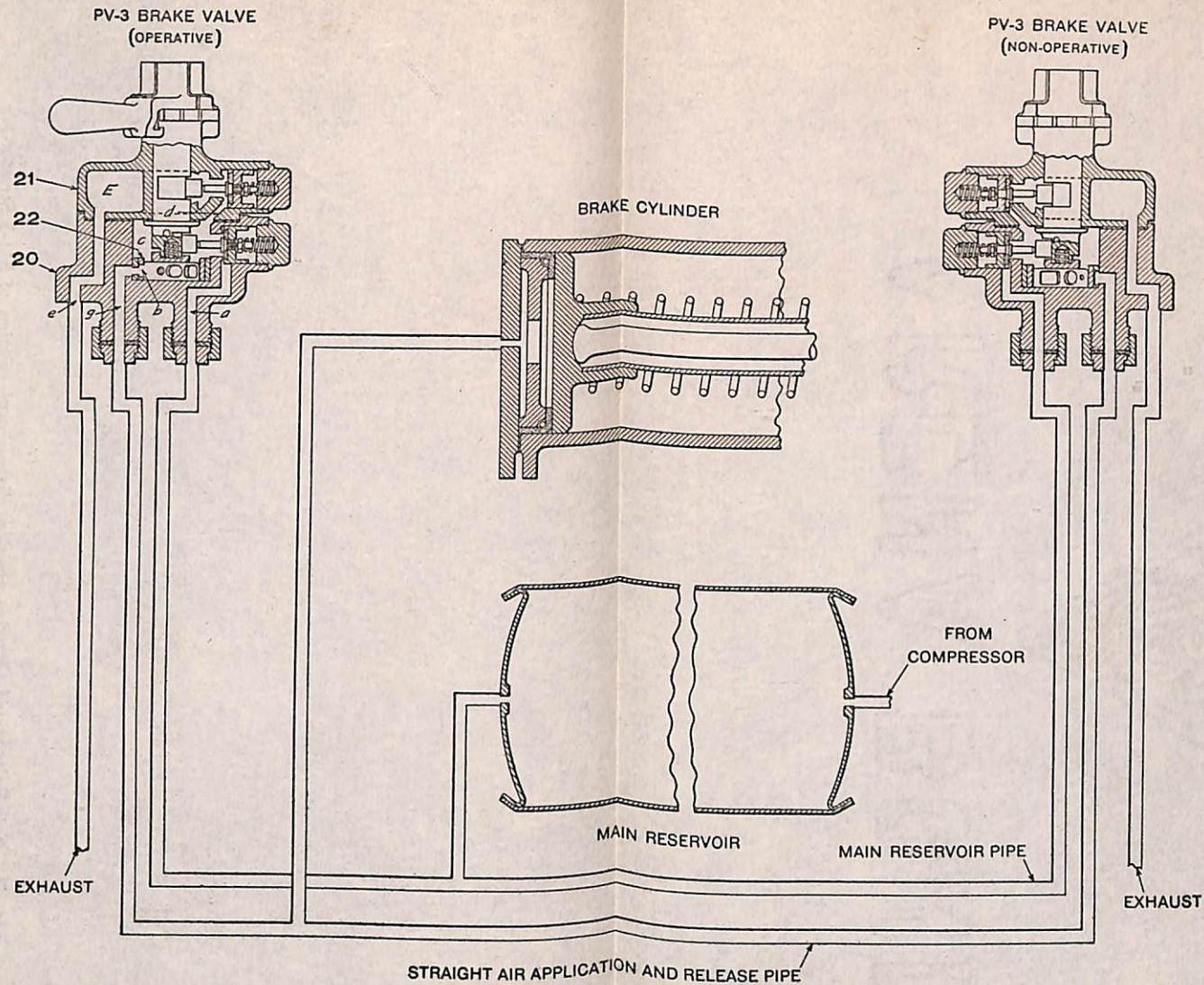

Fig. 21. Full Release and Charging position, diagrammatic section of SM-3 Straight-Air Brake Equipment with PV-3 Brake Valve

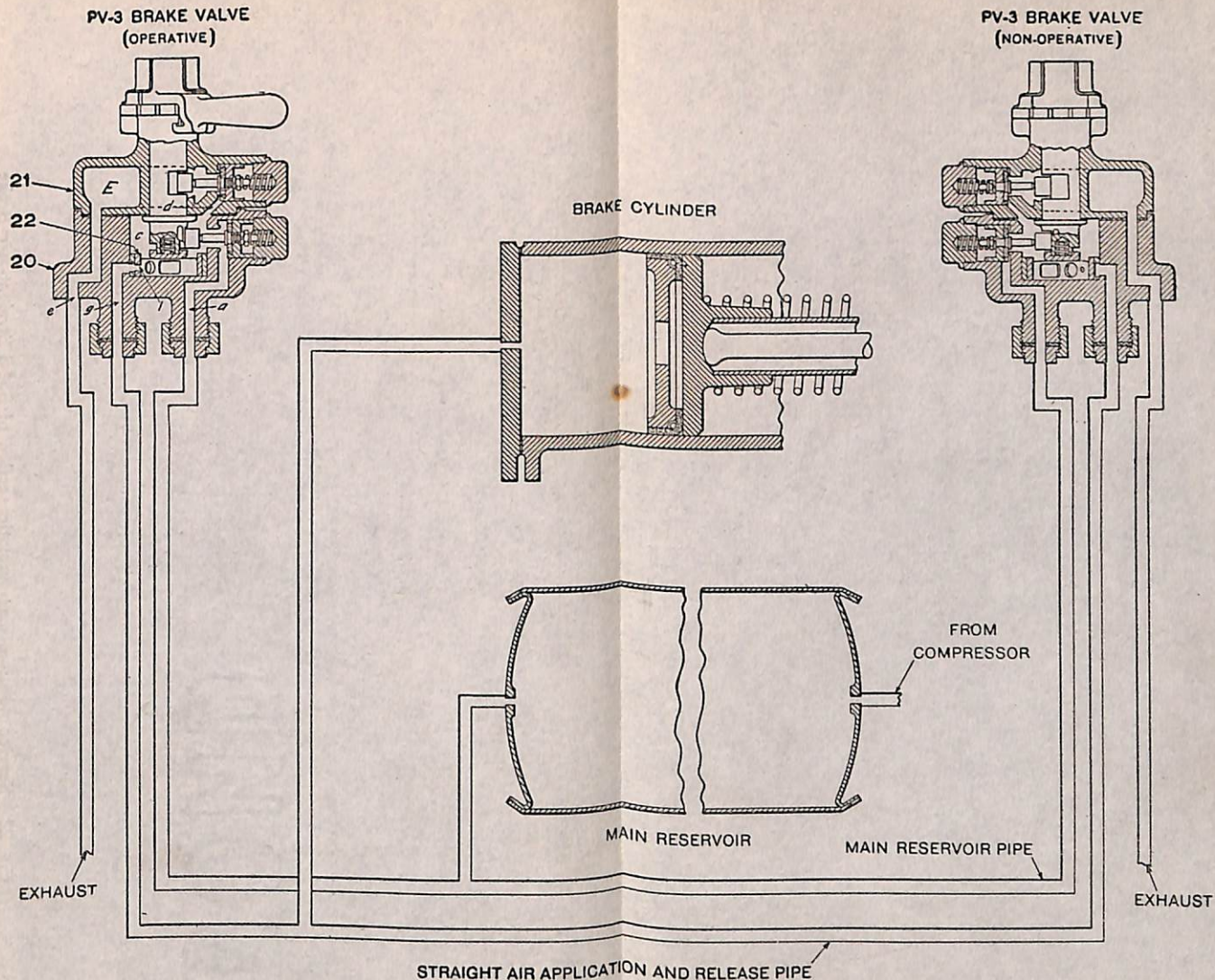

Fig. 22. Service position, diagrammatic section of SM-3 Straight-Air Brake Equipment with PV-3 Brake Valve

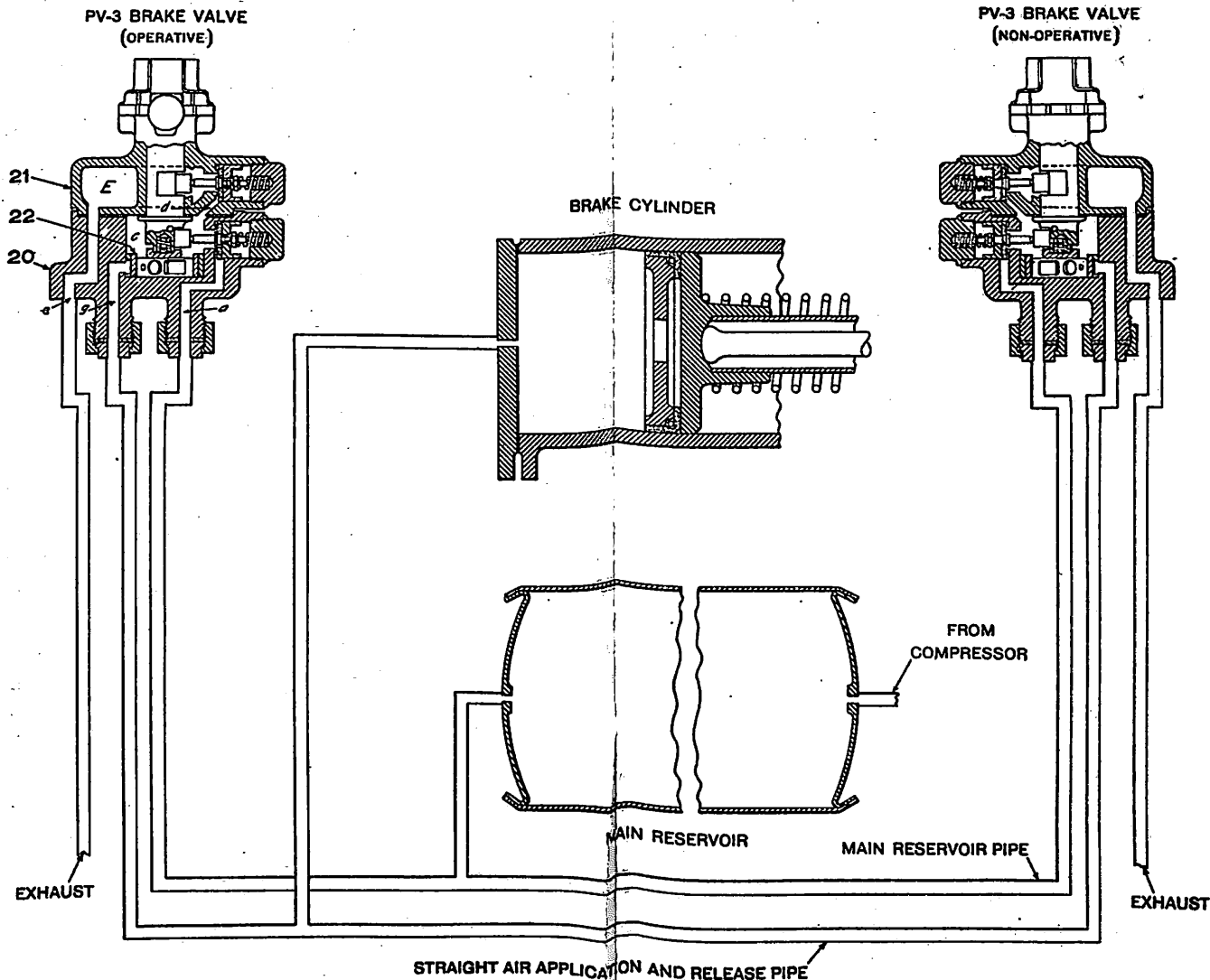

Fig. 23. Lap position, diagrammatic section of SM-3 Straight-Air Brake Equipment with PV-3 Brake Valve

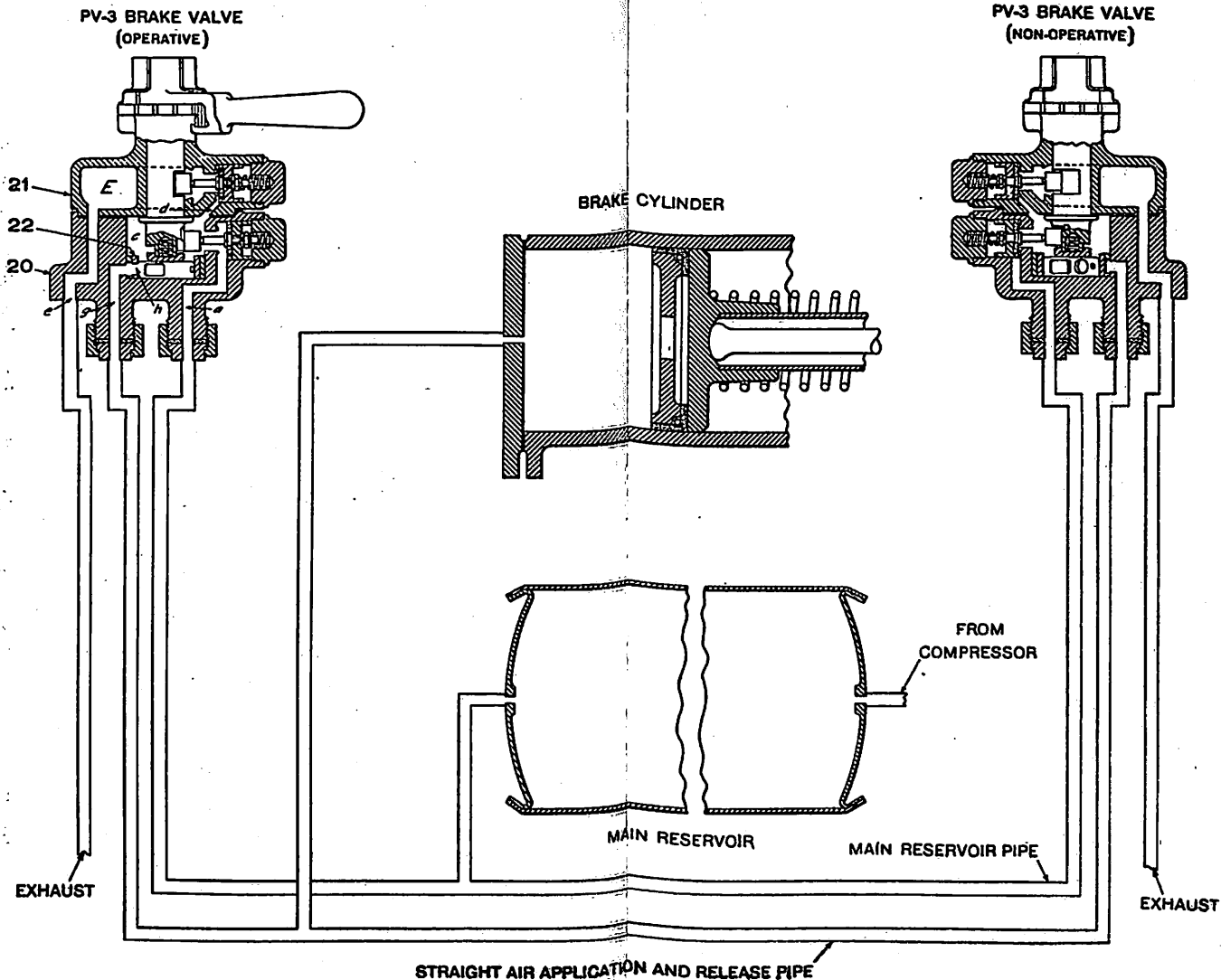

Fig. 24. Emergency position, diagrammatic section of SM-3 Straight-Air Brake Equipment with PV-3 Brake Valve

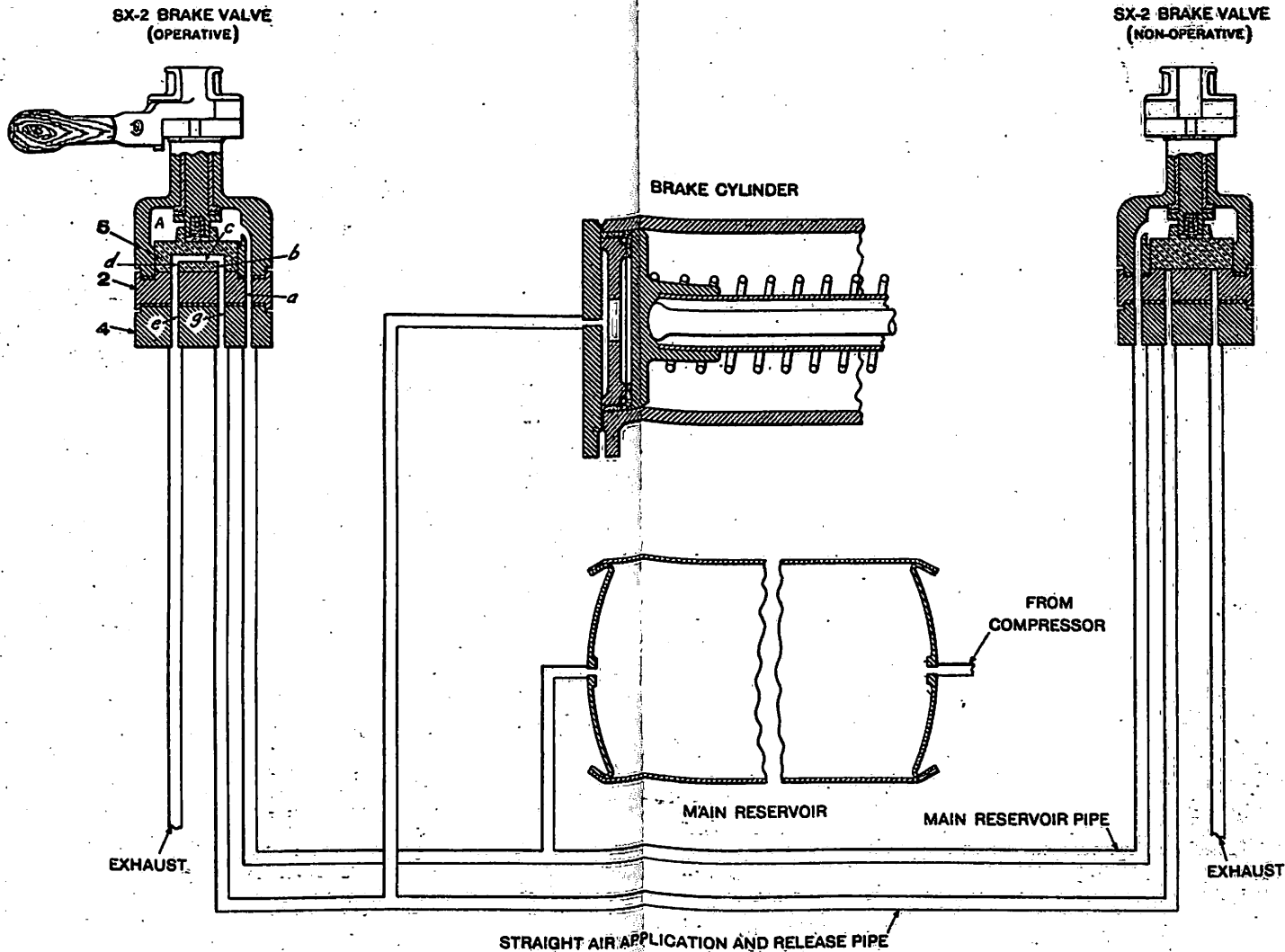

Fig. 25. Running position, diagrammatic section of SM-3 Equipment with SX-2 Brake Valve

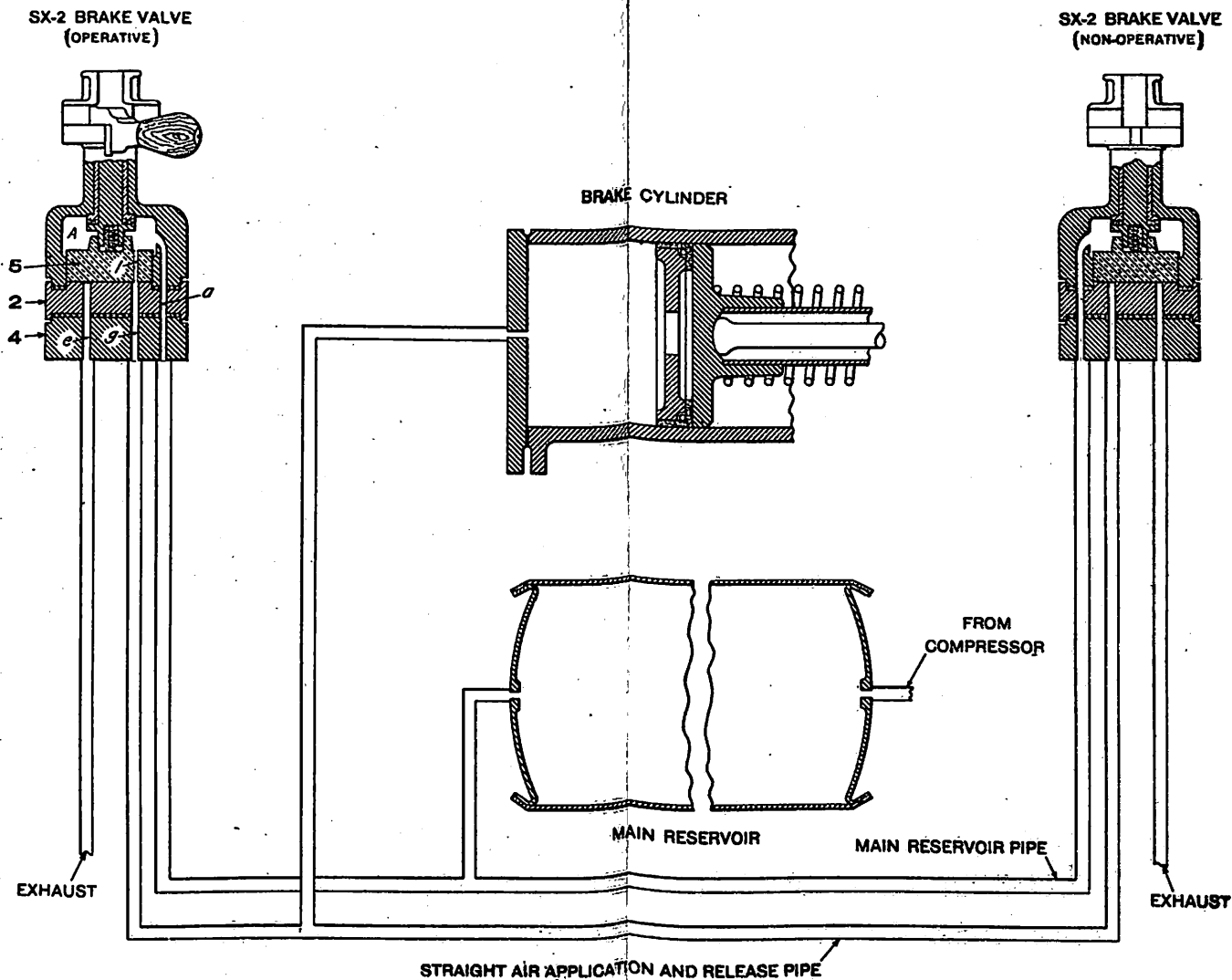

Fig. 26. Service position, diagrammatic section of SM-3 Equipment with SX-2 Brake Valve

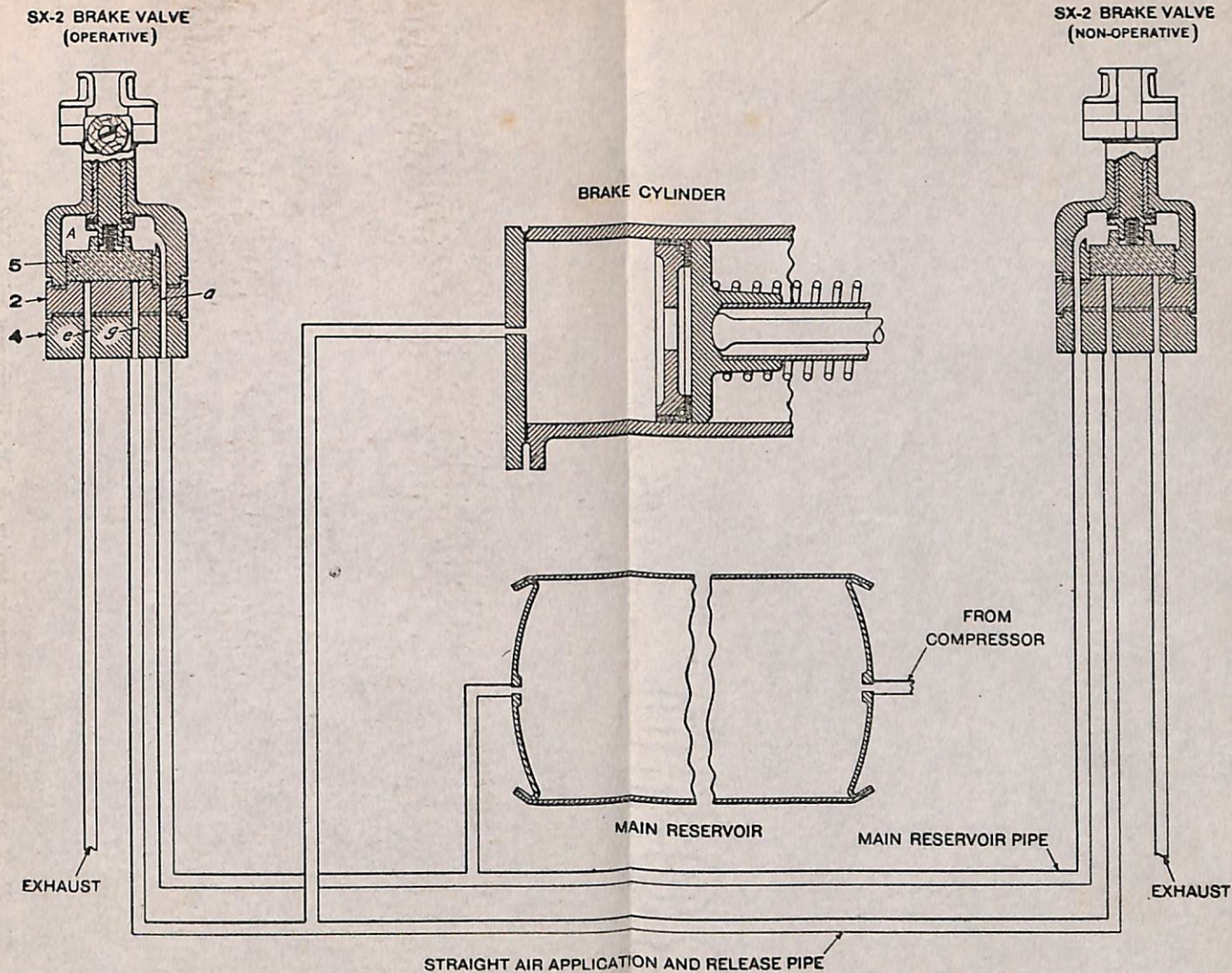

Fig. 27. Lap position, diagrammatic section of SM-3 Equipment with SX-2 Brake Valve

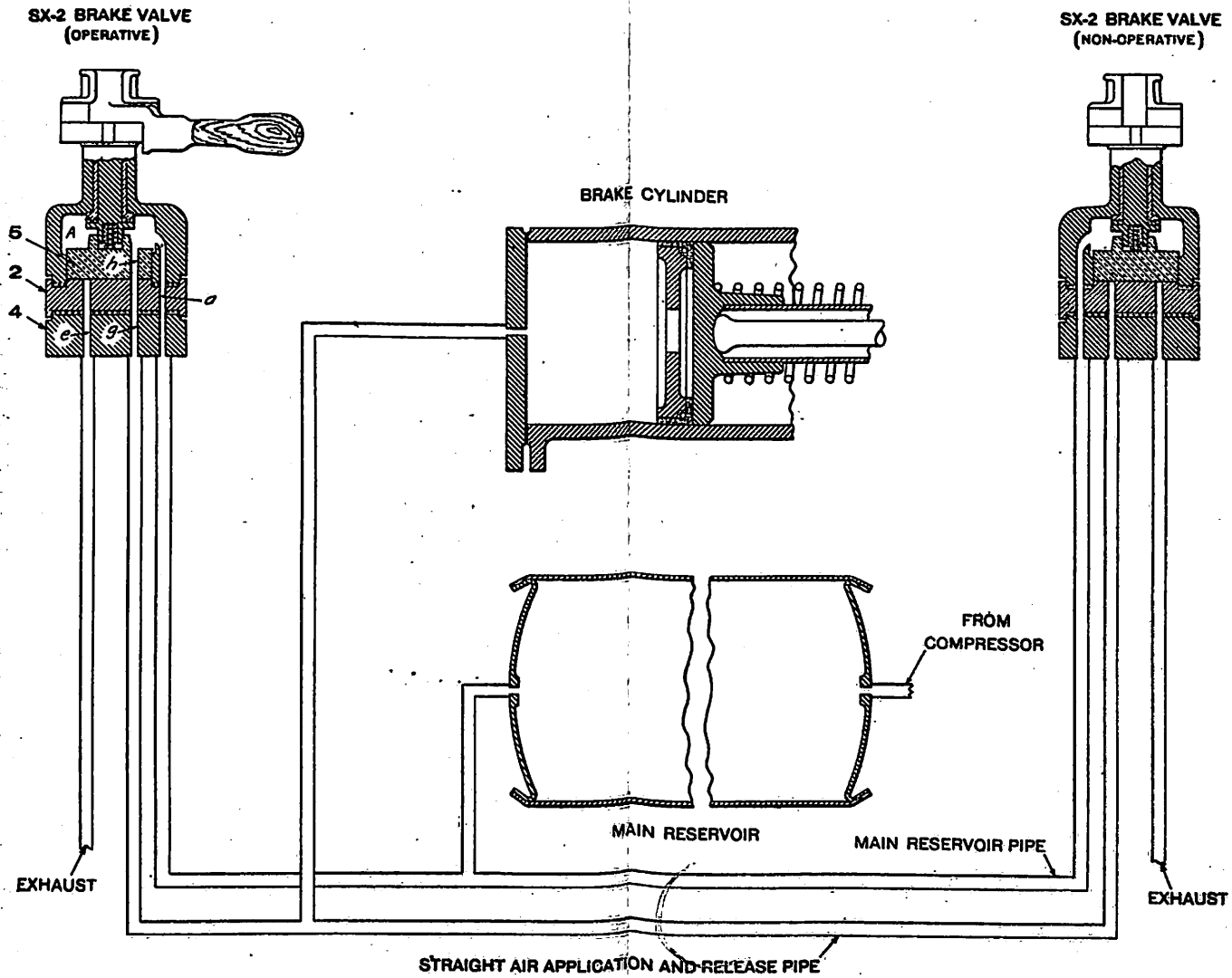

Fig. 28. Emergency position, diagrammatic section of SM-3 Equipment with SX-2 Brake Valve

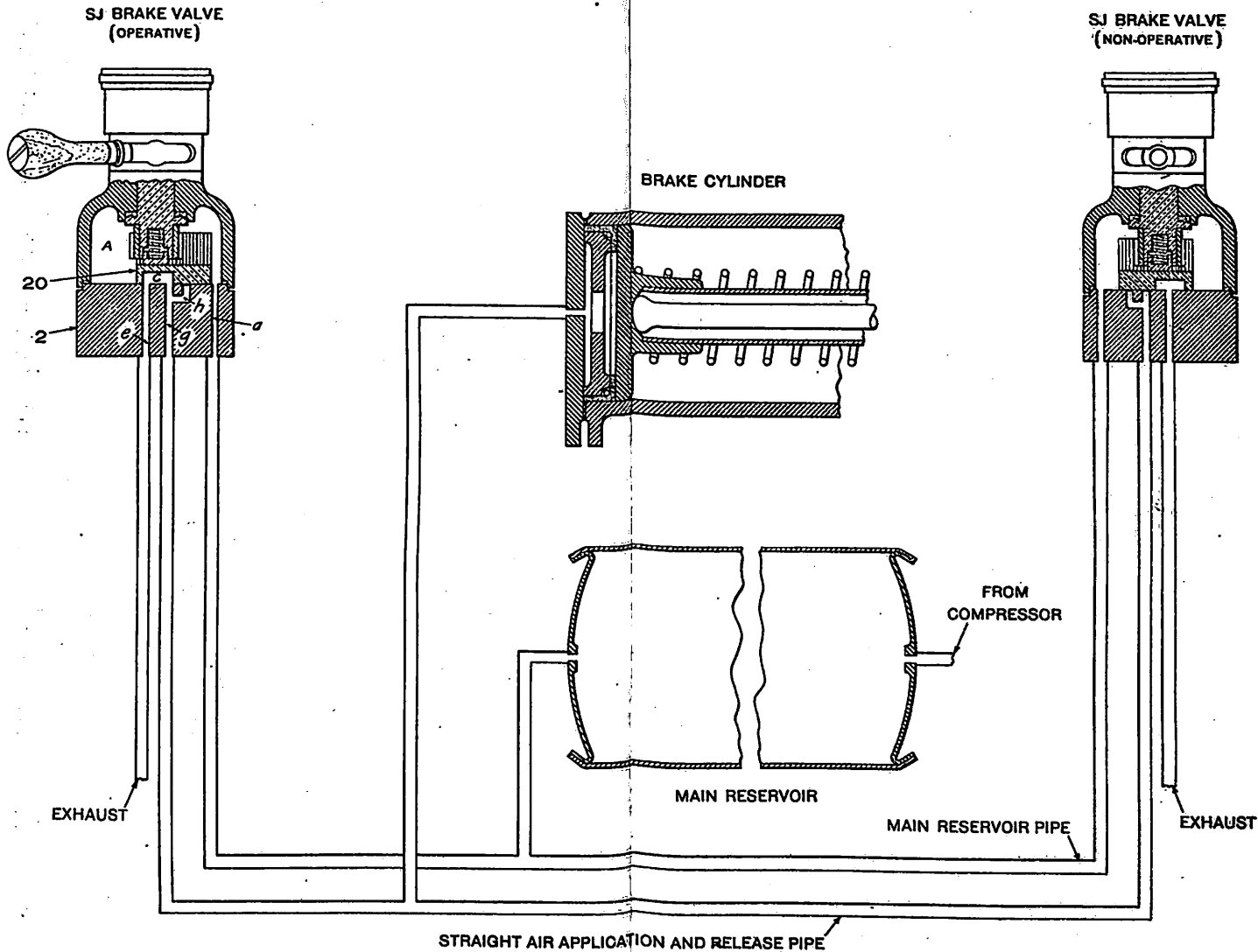

Fig. 29. Running position, diagrammatic section of SM-1 Equipment with SJ Brake Valve

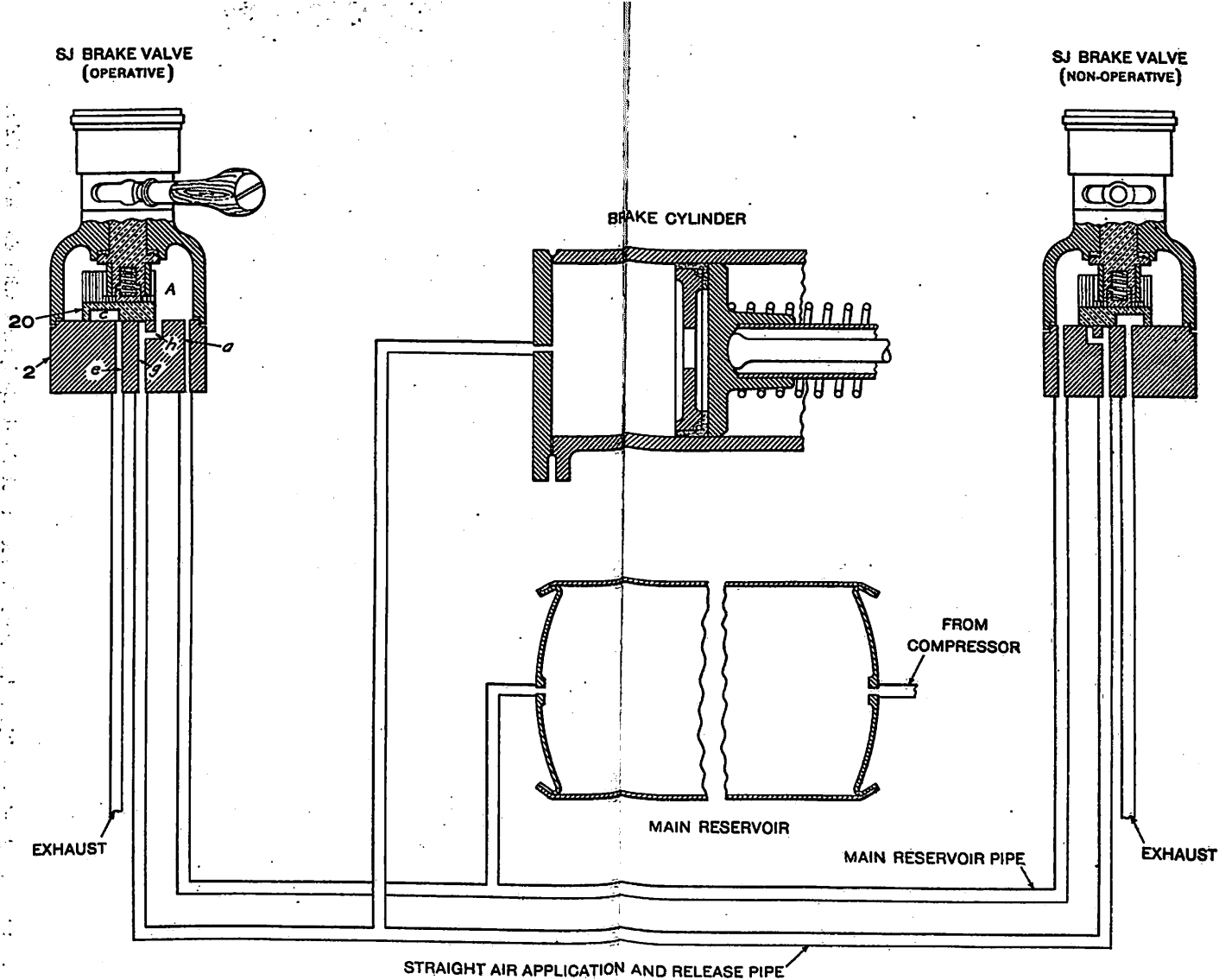

Fig. 30. Service position, diagrammatic section of SM-1 Equipment with SJ Brake Valve

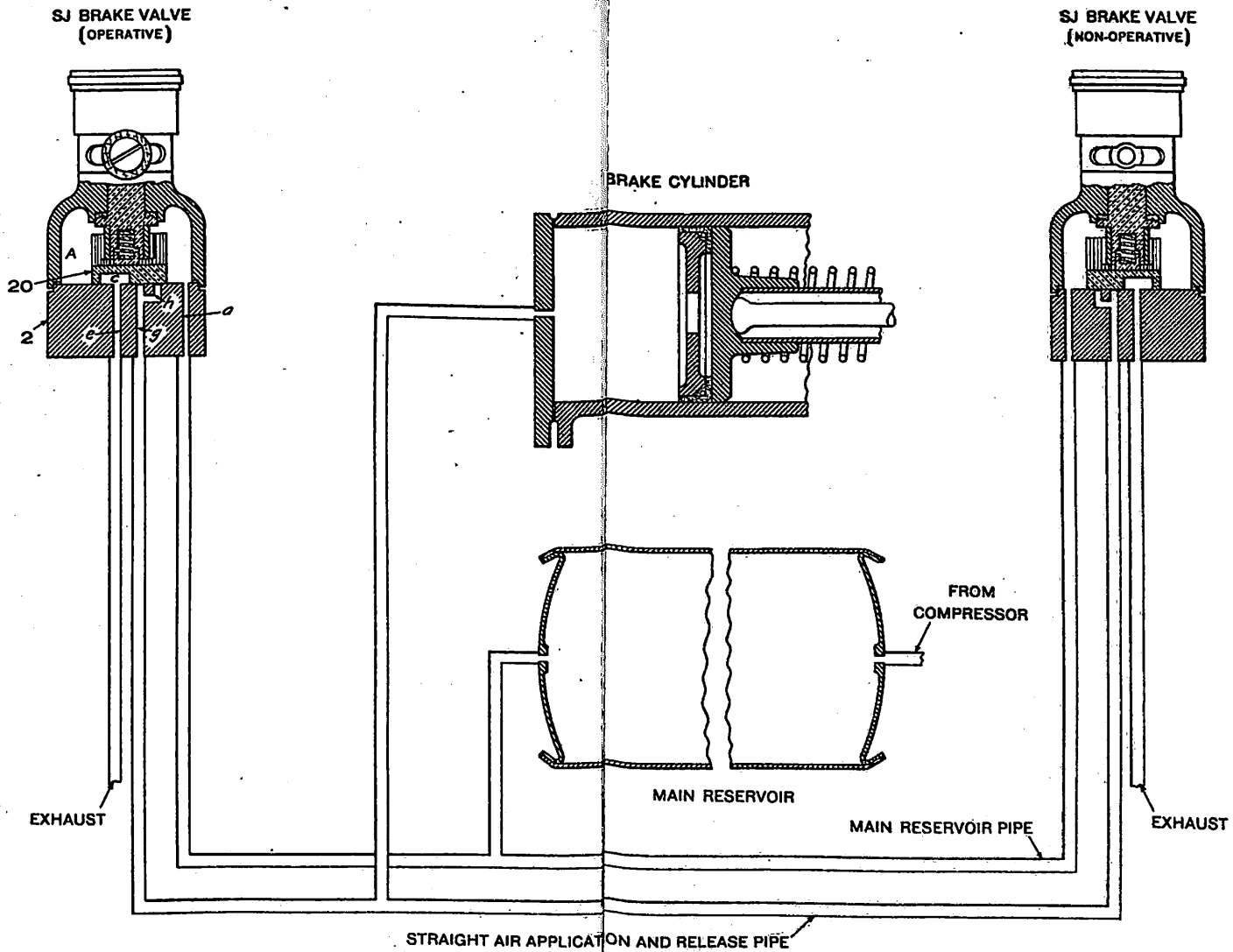

Fig. 31. Lap position, diagrammatic section of SM-1 Equipment with SJ Brake Valve

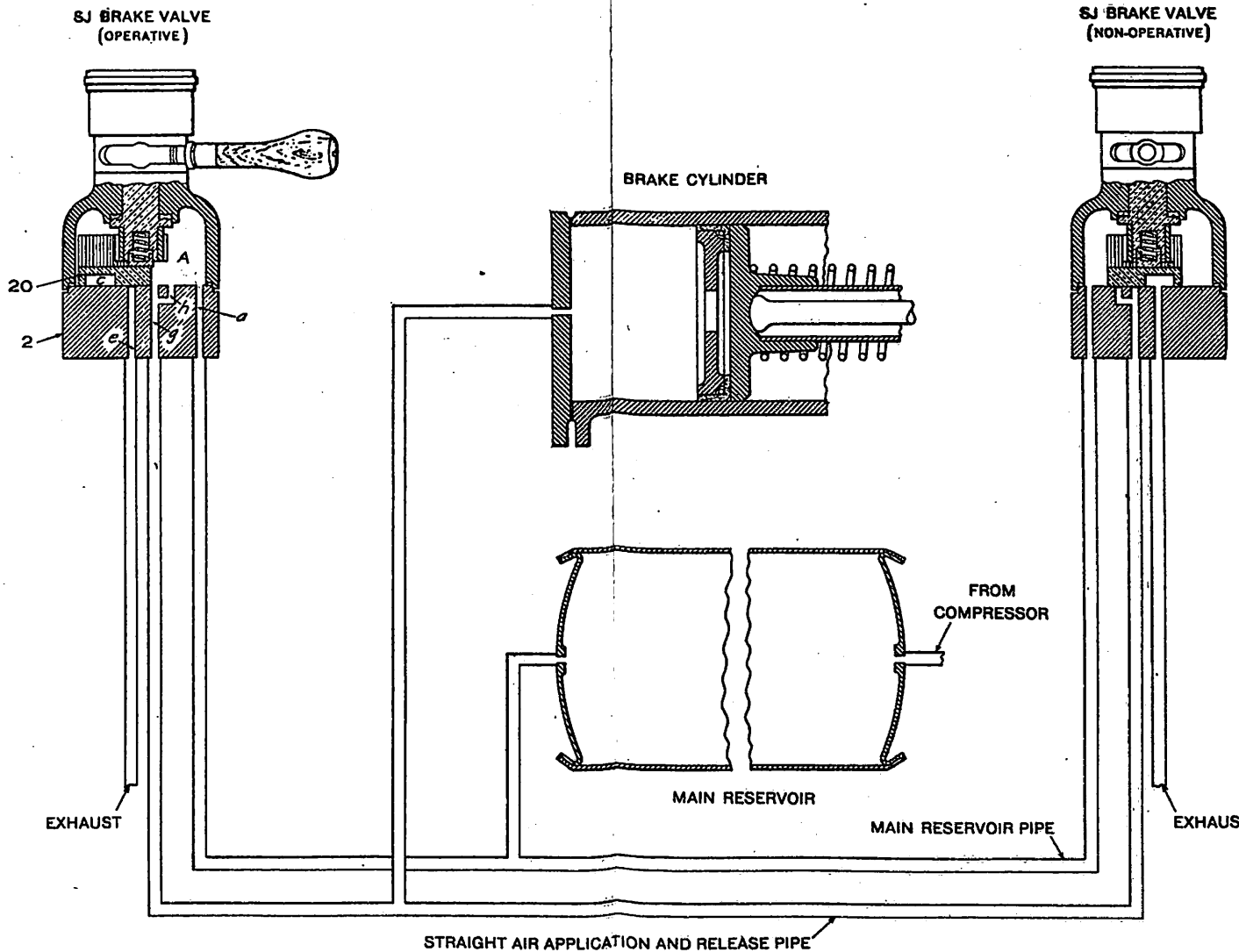

Fig. 32. Emergency position, diagrammatic section of SM-1 Equipment with SJ Brake Valve

